

SGC-120011

GCOM-W1 "SHIZUKU" ***Data Users Handbook***

First Edition

January 2013

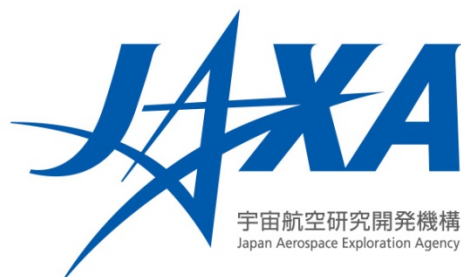

Preface

Global environment change has become a worldwide concern in recent years. JAXA is conducting a project known as “GCOM (Global Change Observation Mission)”. GCOM aims to construct, use, and verify systems that enable continuous global-scale observations (for 10 to 15 years) of effective geophysical parameters for elucidating global climate change, weather forecasting, water circulation mechanisms and for providing fishery information to the fishing industry.

GCOM has two series of observation satellites: the GCOM-W series for observing the water cycle and the GCOM-C series for observing climate change. In order to carry out observations continuously for at least 10 years, six satellites are to be launched in three phases. The GCOM-W1 is the first generation of the GCOM-W satellite.

GCOM-W1 was launched by the H-IIA Launch Vehicle No. 21 (H-IIA F21) at 1:39 a.m. on May 18th, 2012 (Japan Standard Time, JST) from the Tanegashima Space Center, and inserted into a planned position on the “A-Train” orbit(*).

* The Afternoon Constellation, or “A-Train”, is an Earth observation satellite constellation run by NASA, and consists of multiple satellites orbiting the Earth in close proximity at an altitude of about 700km, crossing the equator at around 1:30 p.m. mean solar time. GCOM-W1 is also slated to join the A-Train, with the goal of further expanding scientific research by using data from AMSR2.

GCOM-W1 is equipped with an Advanced Microwave Scanning Radiometer 2 (AMSR2). AMSR2 is the successor of the Advanced Microwave Scanning Radiometer (AMSR) onboard the Advanced Earth Observing Satellite II (ADEOS-II) and the Advanced Microwave Scanning Radiometer for EOS Aqua (AMSR-E) on board Aqua, NASA’s Earth observation satellite. AMSR2 takes measurements at multiple frequencies and multiple polarizations of weak electromagnetic waves in the microwave band radiated from the Earth’s surface and the atmosphere. It is designed to estimate a variety of geophysical parameters, particularly those connected to water. The observation data obtained by AMSR2 is received at ground stations(domestic stations in Japan, foreign station in Norway (SvalSat/KSAT)). Then, the received data is transmitted to JAXA/Tsukuba Space Center via internet and processed into data products and become ready for distribution to users.

AMSR2 will continue global observations with high spatial resolution and at multiple frequencies and multiple polarizations, including low frequency channels by AMSE/AMSR-E. This is made to know its geographical distribution and seasonal and/or yearly changes. The observation data will enable the creation of long-term trustworthy data sets of global physical amount (Total Precipitable Water, Cloud Liquid Water, Pricipitation, Sea Surface Wind, Sea

Surface Temperature, Sea Ice Concentration, Snow Depth, Soil Moisture Content).

AMSR2 Level1 products will be released in January 2013, and further, Level2 and Level3 products will be released in May 2013 from GCOM-W1 Data Providing Service (<https://gcom-w1.jaxa.jp/>).

This handbook intends to make the GCOM-W1 data be acknowledge by users in general and provides the users with information about the GCOM-W1 products as well as the background knowledge of the spacecraft, sensors, ground systems, and so on; thereby promoting a wide use of the data products and serving users with convenience. We hope AMSR2 products as described in this handbook contribute to studies on global environment change monitoring, preservation, and so on.

January 2013

Japan Aerospace Exploration Agency

Team of GCOM Project

GCOM-W1 "SHIZUKU" Data Users Handbook Contents

Chapter 1 Introduction	1-1
1.1 Purpose of this Document.....	1-1
1.2 Scope of this Document.....	1-2
1.3 Overview of the AMSR2 Mission.....	1-2
Chapter 2 Overview of AMSR2.....	2-1
2.1 Overview of GCOM-W1.....	2-1
2.2 Advanced Microwave Scanning Radiometer 2 (AMSR2)	2-3
2.3 A-Train	2-28
Chapter 3 Overview of the GCOM-W1 Ground System	3-1
3.1 Overall System	3-1
3.2 GCOM-W1 Mission Operation System	3-2
3.3 Receiving and Recording Equipment.....	3-5
3.4 Overview of Ground System Operations	3-8
Chapter 4 AMSR2 Products	4-1
4.1 Product Definitions	4-1
4.2 Level 1 Processing Algorithms	4-8
4.3 Higher Level Processing Algorithms.....	4-16
4.4 Project Formats	4-33
4.5 Data Calibration and Verification.....	4-33
Chapter 5 Data Providing Service	5-1
5.1 Product Storage	5-1
5.2 Product Provision Policy	5-2
5.3 User Tools	5-10

List of Tables and Figures

Table 1-1: Geophysical parameters observed by GCOM-W1	1-5
Table 2-1: Main GCOM-W1 specifications.....	2-3
Table 2-2: Main AMSR2 specifications	2-4
Table 2-3: AMSR series comparisons.....	2-5
Table 2-4: AMSR2 architecture.....	2-9
Table 2-5: Main performance values of the antenna.....	2-11
Table 2-6: Main performance values of the HTS	2-12
Table 2-7: Main performance values of the CSM.....	2-13
Table 2-8: Main performance values of the receiver	2-14
Table 2-9: Main performance values of the antenna drive assembly.....	2-15
Table 2-10: Main performance values of the signal processor.....	2-16
Table 2-11: Main performance values of the power distribution unit	2-17
Table 2-12: AMSR2 temperature resolutions (specification values).....	2-21
Table 2-13: Beam width and footprint	2-26
Table 2-14: Overlap ratios (under nominal design conditions).....	2-27
Table 3-1: Ground station satellite operations	3-8
Table 3-2: Definitions of mission data processing.....	3-10
Table 3-3: Product delivery to operational institutions (for JMA).....	3-12
Table 3-4: Product delivery to operational institutions (for JAFIC)	3-13
Table 4-1: AMSR2 product definitions.....	4-1
Table 4-2: AMSR2 scene definitions.....	4-2
Table 4-3: Observation center positions	4-2
Table 4-4: Data specifications for AMSR2 Level 1 products	4-5
Table 4-5: List of AMSR2 Level 2 products.....	4-7
Table 4-6: List of AMSR2 Level 3 products.....	4-8
Table 4-7: Coefficients used in scanning bias corrections	4-13
Table 4-8: Frequencies selected for resampling.....	4-16
Table 4-9: Sea temperature dependency of coefficients a and b.....	4-25
Table 4-10: AMSR2 Level 3 product projection methods and lattice grid sizes	4-33
Table 4-11: Overall AMSR2 schedule	4-34
Table 4-12: Designed accuracy for each AMSR2 geophysical parameter	4-38
Table 4-13: Product descriptions	4-39
Table 5-1: List of supplied data.....	5-1
Table 5-2: Delivery of products for general researchers	5-2

Table 5-3: User categories.....	5-3
Table 5-4: Service contents	5-3
Figure 1-1: Overview of the GCOM mission	1-3
Figure 1-2: JAXA's climatic and environmental observation satellite missions .	1-3
Figure 1-3: Relationships between geophysical parameters and AMSR2 observation frequencies	1-6
Figure 1-4: Examples of hydrological cycle observations.....	1-7
Figure 1-5: Examples of North Pole sea ice distribution observations.....	1-8
Figure 1-6: Example of observations of El Nino and La Nina trends	1-8
Figure 1-7: Example of soil moisture content observations	1-9
Figure 1-8: Example of a fishing industry application	1-10
Figure 2-1: Exterior views of GCOM-W1	2-2
Figure 2-2: Exterior view of AMSR2	2-4
Figure 2-3: AMSR2: Principle of operation	2-7
Figure 2-4: Exterior schematic of AMSR2.....	2-10
Figure 2-5: AMSR2 mode transitions.....	2-20
Figure 2-6: Exterior view of the CAL.....	2-22
Figure 2-7: Illustration of AMSR2's geometric performance (off-nadir and incidence angle)	2-23
Figure 2-8: Layout of the feed-horn assembly	2-24
Figure 2-9: Illustration of AMSR2's geometric performance (sampling interval, beam width, footprint, and overlap)	2-25
Figure 2-10: View of the A-Train	2-29
Figure 3-1: Overview of the GCOM-W1 ground system	3-1
Figure 3-2: Overview of AMSR2 data processing.....	3-3
Figure 3-3: Home window of the GCOM-W1 data providing service	3-5
Figure 3-4: View of Katsuura Station	3-6
Figure 3-5: View of Tsukuba Station	3-6
Figure 3-6: View of KSAT / Svalbard Station (taken from the KSAT website) ...	3-7
Figure 3-7: View of KSAT / Troll Station (taken from the KSAT website)	3-9
Figure 4-1: Relationship between the AMSR2 scene definitions and the position directly under the satellite.....	4-3
Figure 4-2: Relationship between the scan center observation point location and the number of data points.....	4-3
Figure 4-3: Definition of the Northern polar stereo projection [TB/SIC]	4-4
Figure 4-4: Definition of the Southern polar stereo projection [TB/SIC].....	4-4

Figure 4-5: Definition of the Northern polar stereo projection [TB/SND]	4-5
Figure 4-6: Level 1A product processing sequence.....	4-9
Figure 4-7: Processing sequence for calculating the observation points	4-9
Figure 4-8: Sketch of calculating the longitude/latitude of observation point ..	4-10
Figure 4-9: Processing sequence for calculating the antenna temperature conversion coefficients	4-11
Figure 4-10: Processing sequence for the Level 1B product	4-12
Figure 4-11: Processing sequence for Level 1R products	4-14
Figure 4-12: Overview of the Level 1R process.....	4-15
Figure 4-13: Method of correcting S36 for anisotropy	4-25
Figure 5-1: Level 1 / Level 2 granule ID assignment rules.....	5-5
Figure 5-2: Level 3 granule ID assignment rules	5-5
Figure 5-3: Search window (guest user).....	5-10
Figure 5-4: User tool acquisition methods (1 / 2)	5-11
Figure 5-5: User tool acquisition methods (2 / 2)	5-11

Chapter 1 Introduction

The expanding range of human activities in pursuit of abundance and richness is beginning to have a profound impact on the planet's environment, such as climate warming and widening ozone holes, on a scale that cannot be ignored. Given this reality, the abundance and richness the human race should pursue from this point forward should encompass more than our daily abundance; it should include a sound human society and a healthy global environment that we can pass on without guilt to our children's and grandchildren's generations. To attain and preserve a future healthy global environment, it is imperative that we understand the current state of the global environment and its underlying mechanisms, forecast future trends, and connect this knowledge and prescience to meaningful environmental preservation and improvement measures.

Essentially, we have two means of observing and measuring our planet's environment at our disposal. One is direct measurement of observable phenomenon on land and at sea. The second is remote sensing from satellites and other remote platforms via visible and infrared light, microwaves, and other electromagnetic waves. The latter method, although requiring various algorithms and processing to derive observables, is nonetheless essential to observing at once phenomena on a global scale.

The Japan Aerospace Exploration Agency (JAXA) manages the Global Change Observation Mission (GCOM), a mission that uses satellites to observe the global environment. In effect, this mission's role is like a health check of the Earth from space, as it observes global hydrological mechanisms and climate changes over a long time period.

The first stage of the GCOM-W series is the Global Change Observation Mission 1st-Water "Shizuku" (GCOM-W1) satellite, which observes hydrological mechanisms. GCOM-W1 carries the Advanced Microwave Scanning Radiometer 2 (AMSR2), which is capable of measuring, among other phenomenon, precipitation, water vapor, sea surface wind speeds, sea surface temperatures, soil moisture content, and snow depths.

1.1 Purpose of this Document

This document provides users who obtain AMSR2 data sets publically released by JAXA with the information needed to make effective use of these data sets. It also gives information related to both standard products and other products, the GCOM-W1 satellite, the onboard AMSR2 sensor, and the ground system.

1.2 Scope of this Document

This document provides information needed by AMSR2 data users as well as brief descriptions of the satellite, its sensor, the ground system, the products, and the data providing service. The document includes information users need to access the data providing service in order to obtain data sets. Furthermore, the annex gives details on each product format. The document's overall structure is as below:

Chapter 1 — Preface

Chapter 2 — Overview of the AMSR2

Chapter 3 — Overview of the GCOM-W1 Ground System

Chapter 4 — AMSR2 Products

Chapter 5 — Data Providing Service

Annex — List of Abbreviations, Related Information, AMSR2 Product Formats

1.3 Overview of the AMSR2 Mission

AMSR2 is the GCOM-W1 satellite's onboard sensor system. This section gives a description of the GCOM concept as a background to the measurement sensor, followed by an explanation of the AMSR2 itself.

1.3.1 GCOM Concept

GCOM consists of two series: Global Change Observation Mission – Water (GCOM-W) and Global Change Observation Mission – Climate (GCOM-C). GCOM-W makes observations connected with water and energy cycles on a global scale, including the polar regions, using an onboard microwave scanning radiometer. GCOM-C is responsible for long-term continuous observations of parameters connected with the Earth's radiant energy budget and with the state of vegetation growth, particularly as it relates to food production and the carbon cycle. These parameters are associable to the balance of the Earth's overall climate. GCOM-C carries an onboard multi-spectral optical radiometer to make these observations.

Through long-term observations (10 to 15 years) of the entire planet, GCOM is expected to monitor hydrological cycles and climate changes and to clarify their mechanisms. To carry out continuous observations for more than 10 years, each satellite series is divided into three stages, meaning that a total of six satellites are planned to be launched. Subsequent satellites will overlap the on-orbit operation period of the former satellites by approximately one year to allow for comparisons

and calibrations of both observation sensors to ensure observation data continuity.

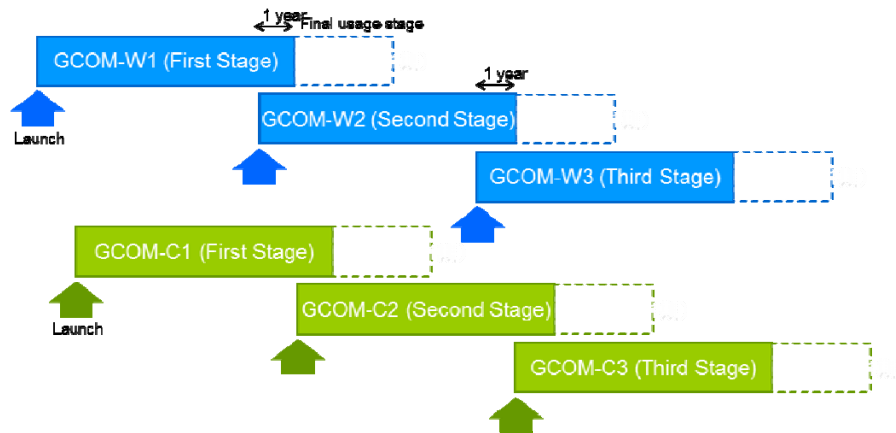

Figure 1-1: Overview of the GCOM mission

Given the sheer size of our Earth, it is impossible for a single country to make all the observations necessary to gauge the Earth's environmental changes. Instead, various countries proceed with their own satellite plans for climatic and environmental observations within a worldwide framework known as the Global Earth Observation System of Systems (GEOSS), which facilitates international collaborations. Japan has three priority fields: global warming and carbon cycle changes, hydrological cycle changes and climate changes, and natural disasters. GCOM's mission contributes to GEOSS, and GCOM is intended to make international contributions in coordination with other domestic and international programmes, such as the Joint Polar Satellite System (JPSS), belonging to the United States' National Oceanic and Atmospheric Administration (NOAA).

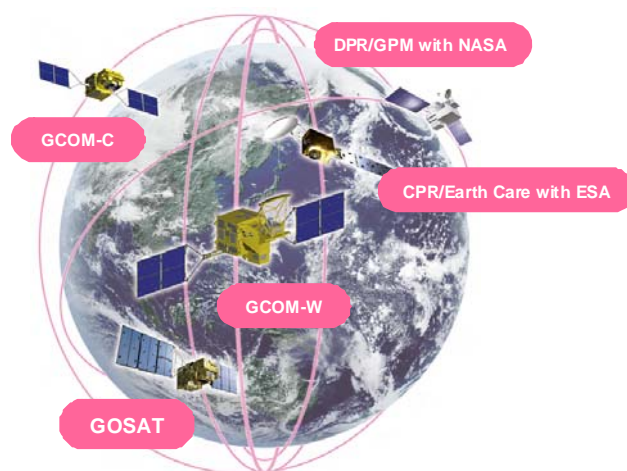

Figure 1-2: JAXA's climatic and environmental observation satellite missions

1.3.2 Overview of the AMSR2 mission

1.3.2.1 Importance of observing hydrological changes

The water on the Earth's surface plays a very important role in redistributing solar energy streaming down on the surface and is intimately connected to meteorological phenomena and climate change. Water in the oceans and on land, in both liquid and solid states, is evaporated or sublimated by solar energy and carried as water vapor from the Earth's surface to the atmosphere.

The water vapor transported into the atmosphere after a time is cooled and reverts back to liquid or solid water in the form of clouds or precipitation. The energy present in the gas-phase water vapor heats the atmosphere, becoming a driving force causing all kinds of meteorological phenomena. At the same time, water that has changed to liquid or solid form in the atmosphere returns to the Earth's surface as rainfall or snowfall. This water either flows back to the oceans via rivers or is stored inland as soil moisture, snow accumulations, or frozen soil. The water stored in land functions as a sort of climate memory, because it stores the current state for a certain period of time. Thus, water stored in land is equal in importance to the oceans, and the tremendous volume of water they hold, in medium and long term changes to the Earth's intricate systems.

This circulation of water on the Earth is indispensable to our lives. Rain is important for maintaining ecosystems, and it brings about many blessings to human society. On the other hand, typhoons, hurricanes, and torrential rains can, on occasions, cause massive damage to social infrastructure and claim human lives. Droughts, too, damage ecosystems and inflict direct harm to agricultural crops. There are concerns that further temperature increases will unleash more frequent extreme weather phenomena, such as hurricanes, torrential rains, and droughts. At issue in these transformations is ensuring effective use of rainfall as a water resource while minimizing damage caused by natural disasters. This is what makes monitoring the current state of the Earth's hydrological cycle so important, along with understanding the underlying mechanisms of the hydrological cycle using accumulated observation data sets and predicting the behavior of transformations in the short, medium, and long term.

Table 1-1: Geophysical parameters observed by GCOM-W1

Geophysical Parameter	Observation Region	Spatial Resolution (approximate value)
Total Precipitable Water	Global oceans	15 km
Integrated cloud liquid water	Global oceans	15 km
Precipitation	From Tropical to Temperate zones	15 km
Sea surface temperature	Global oceans	15 km
Sea surface wind speed	Global oceans	15 km
Sea ice concentration	High-latitude regions	50 km
Snow depth	Land	30 km
Soil moisture content	Land	50 km

1.3.2.2 Applications microwave observations and data

GCOM-W1 uses a microwave scanning radiometer to observe water in various forms connected to the hydrological cycle with great accuracy on a global scale. Microwave scanning radiometers take advantage of microwaves' sensitivity to water in order to measure microwave energy that contains what is in effect "water data." Because the Earth's surface and particles in the atmosphere are the radiation sources and, thus, this method does not need sunlight, it is particularly well suited for making measurements at night and at the poles in winter. Also, with microwaves, how the object of interest appears changes depending on the observed frequency range. For example, high frequencies with shorter wavelengths are sensitive to clouds and precipitation, whereas low frequencies with longer wavelengths pass through clouds for observations of the Earth's surface. GCOM-W1 measures phenomena over seven frequency bands, from the 6.9 GHz band to the 89 GHz band, in order to take advantage of this property and make quantitative observations of geophysical parameters related to the hydrological cycle.

The measured data include precipitation and water vapor, important components of the atmosphere state, the area of North Pole sea ice, where there are concerns the ice pack is shrinking, soil moisture content, which helps our understanding of droughts and floods and may have applications in the agriculture sector, and sea surface temperatures in all weather conditions, which are particularly helpful for oceanographic observations of the Kuroshio and other currents. Measured data are provided to researchers in various fields as satellite products.

This measurement data are becoming indispensable to numeric weather forecasting, the fishing industry, and other current applications. At the present time, the Japanese Meteorological Agency, the Japan Fisheries Information Service Center, and other institutions routinely use data from the Advanced Microwave Scanning

Radiometer for EOS (AMSR-E) for weather predictions, and particularly rainfall predictions related to typhoons and torrential rains, as well as for creating information on fishing and oceanographic conditions to help understanding of fishing grounds. AMSR2, onboard the GCOM-W1, has a number of improvements over AMSR-E and is expected to deliver data with even higher utility value.

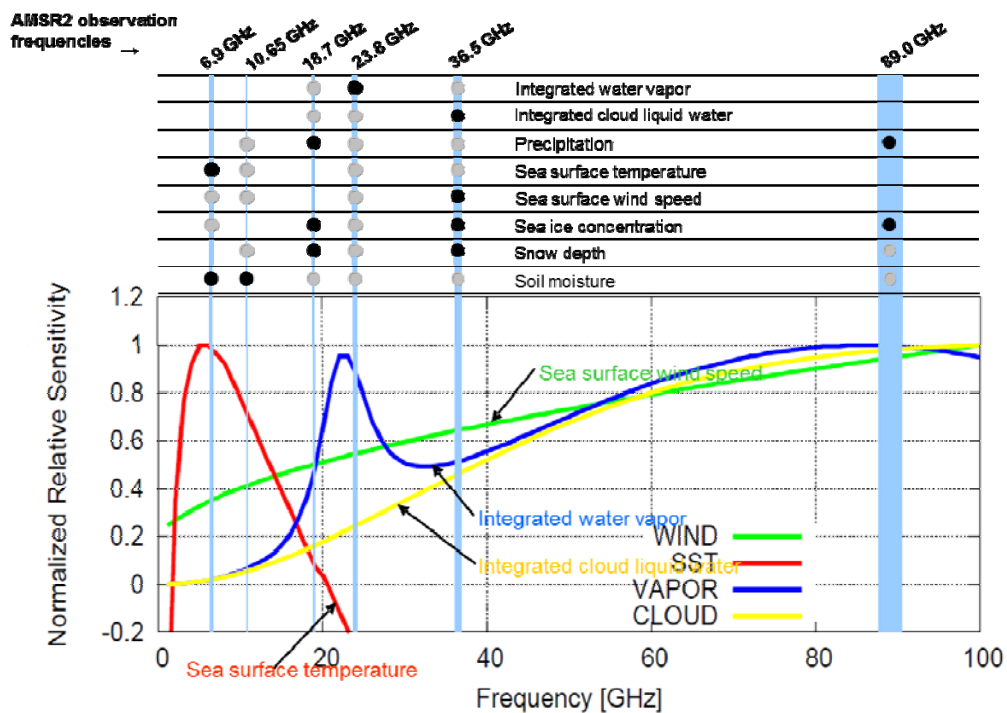

Figure 1-3: Relationships between geophysical parameters and AMSR2 observation frequencies

Figure 1-4 provides global distributions of four geophysical parameters averaged for the month of April 2004 measured by AMSR-E, a previous-generation sensor to the AMSR2. The geophysical parameters are sea surface temperature (upper left), Total Precipitable Water (upper right), sea surface wind speed (lower left), and precipitation (lower right, monthly aggregate value).

April 2004 was comparatively close to normal seasonal values, as neither El Nino nor La Nina was active. In this state, the sea surface temperatures off the coast of Peru in the eastern Pacific Ocean near the equator are cooler than their surroundings due to upwelling, as shown in the upper left figure. The lower right figure of precipitation distributions shows a distinctive belt of heavy rains that stretches just north of the western equator. This is the area known as the intertropical convergence zone, where lower strata winds converge. A similar convergence zone is seen in the southern hemisphere. In the tropics at this time of

year, the Total Precipitable Water distribution (upper right), which indicates the amount of water vapor in the atmosphere, agrees closely with the precipitation distribution. In the Antarctic Ocean region, the latitudes have been dubbed the Roaring Forties, the Furious Fifties, and the Screaming Sixties for the ferocity of their winds and waves. The truth in these sayings is borne out by sea surface wind speed observations (lower left) of extremely strong winds around Antarctica. In similar fashion, GCOM-W1 will be able to measure, almost simultaneously, multiple sets of hydrological cycle data on a global scale.

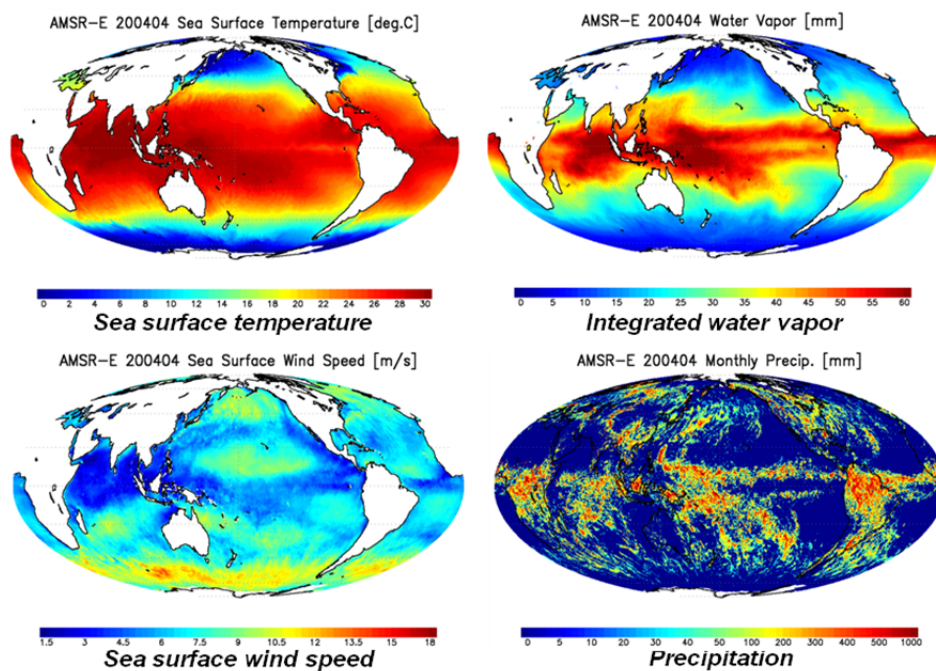

Figure 1-4: Examples of hydrological cycle observations

1.3.2.3 Data Application Example 1 — Observations of sea ice distribution at the North Pole

Figure 1-5 provides sea ice distributions at the North Pole observed by AMSR-E. From the left, these figures show the mid-September sea ice distribution in 2002, 2007, and 2010. In 2007, the smallest sea ice coverage ever in the history of satellite observations was recorded; an area of sea ice equivalent to 2.8-times the size of Japan's total land mass had disappeared since 2005, the year in which the previous smallest sea ice coverage had been recorded. Sea ice had even disappeared from northern Canadian islands, where in normal years the sea ice never melts, opening up a long Arctic Ocean sea route joining the Atlantic and Pacific.

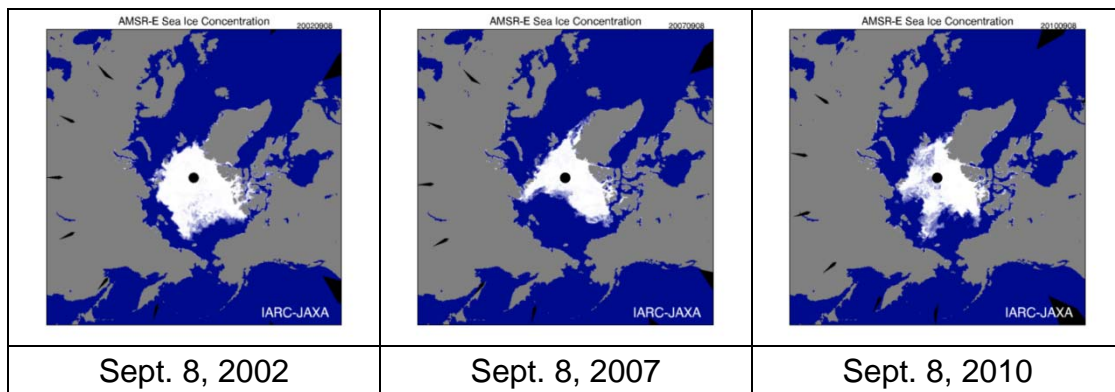

Figure 1-5: Examples of North Pole sea ice distribution observations

1.3.2.4 Data Application Example 2 — Observations of El Nino and La Nina trends

Figure 1-6 provides an example of AMSR-E observations of El Nino and La Nina trends. The top figure, which illustrates the sea surface temperature distribution at the start of September 2010, shows cold water rising from the deep sea being carried westward along the equator beginning off the Peru coast. The bottom figure shows a time series of deviations from normal sea surface temperatures in the sea area where El Nino is monitored (shown by the black box in the top figure). From this figure, you can see that sea surface temperatures are in a negative deviation as of September 2010, indicating a La Nina episode.

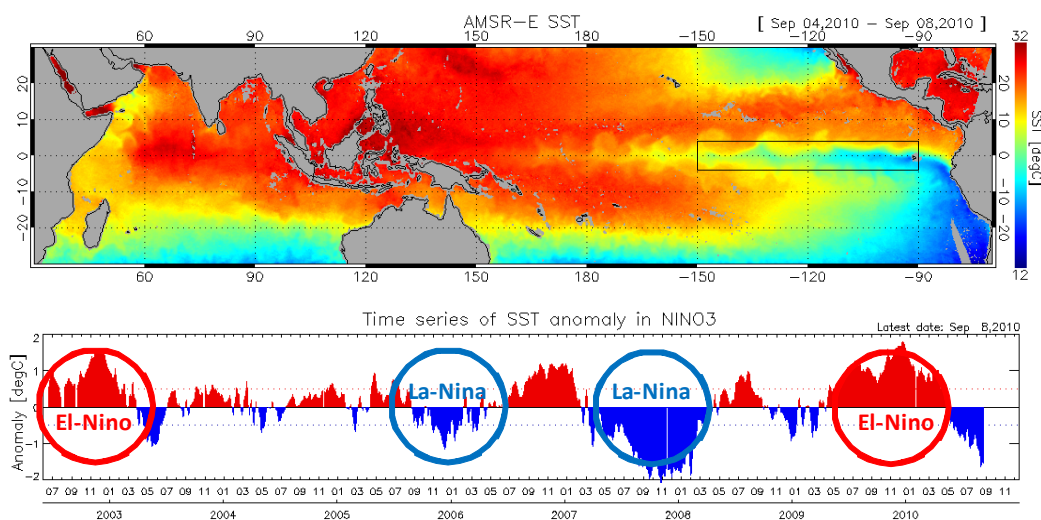

Figure 1-6: Example of observations of El Nino and La Nina trends

1.3.2.5 Data Application Example 3 — Observations of soil moisture content

A massive drought occurred in Russia in the summer of 2010, causing extensive

damage to crops. The top figure in Figure 1-7 shows in red the areas in Russia with drier soil than normal values taken from AMSR-E soil moisture content observations in July 2010. The bottom figure shows changes in AMSR-E soil moisture observations between March and August for the area marked by the blue box in the top figure. The black line indicates normal values, and the red line indicates 2010 readings.

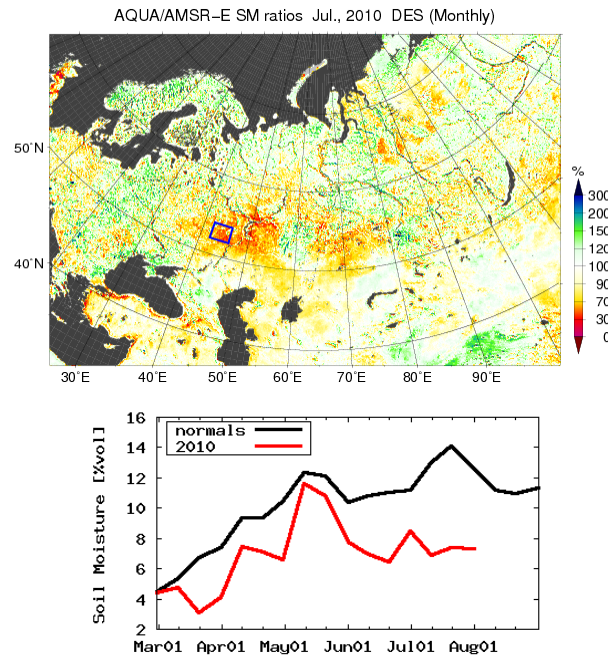

Figure 1-7: Example of soil moisture content observations

1.3.2.6 Actual Data Application Example — Use in the fishing industry

Information such as ocean conditions and the distribution of fish stocks are key to efficient fishing industry operations. One of the most basic pieces of information to ascertain these conditions is sea temperatures. Fish are sensitive to the surrounding water temperatures, and certain water temperatures are conducive to certain species. For example, fish distributed in warm currents prefer warmer water, and fish distributed in cold currents prefer cooler water.

Figure 1-8 plots on AMSR-E/SST images taken over October 19 – 21, 2003 (top figure) and October 19 – 21, 2004 (bottom figure) the locations of fishing grounds at the respective time. Sardine and mackerel roll-net fishing grounds are marked in yellow, bonito trolling fishing grounds are marked in blue, tuna and other trawl line fishing grounds are marked in red, and saury stick-held dip net fishing grounds are marked in green. What is particularly noteworthy is the formation of saury fishing grounds offshore in 2003, as the Kurile current spread widely to the south. In 2004,

however, the fishing grounds formed along the coast as a warm water mass was distributed along eastern Hokkaido. Bonito fishing grounds also formed offshore during this season in 2003.

Fishing grounds can be identified by sea water temperatures because fishing grounds form where the water temperatures suit the specific species. Because satellite sensors like AMSR2 that use microwaves are only slightly affected by cloud cover, it is possible to obtain continuous sea surface temperature data that are useful in determining fishing ground locations.

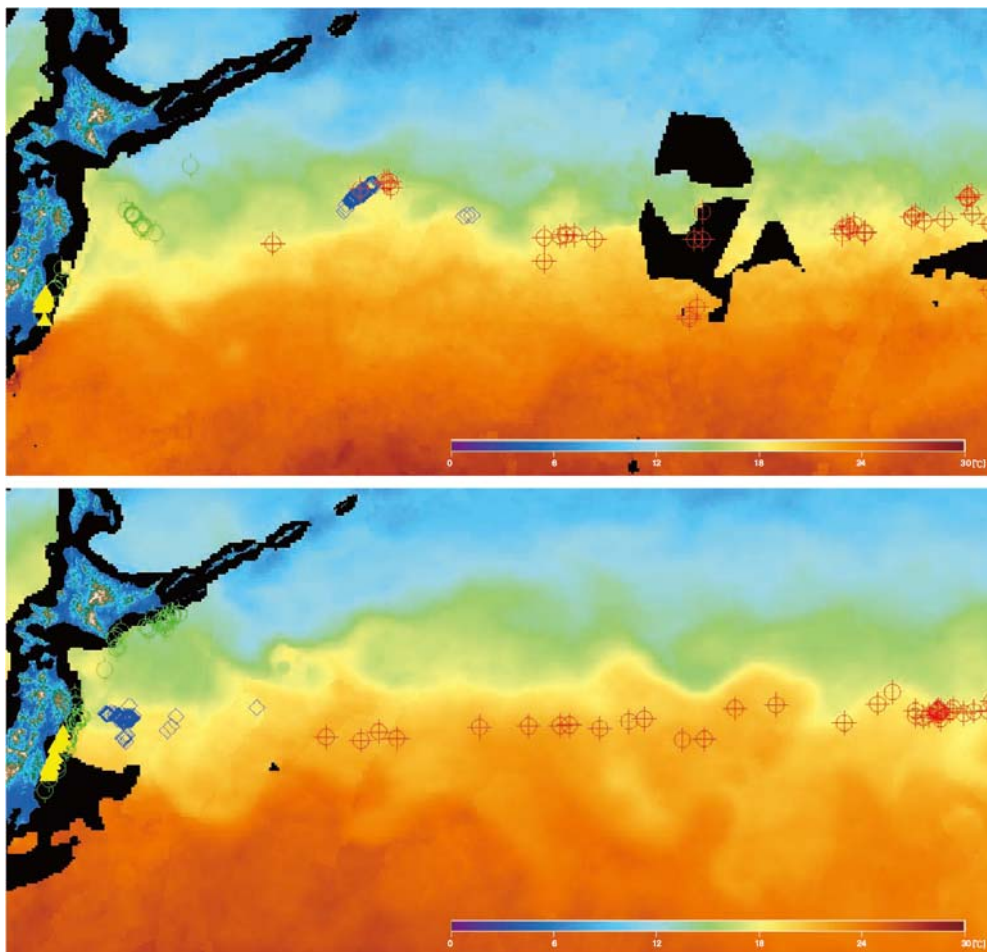

Figure 1-8: Example of a fishing industry application

Chapter 2 Overview of AMSR2

The first satellite of the GCOM-W series, GCOM-W1, carries the Advanced Microwave Scanning Radiometer 2 (AMSR2). AMSR2 is the successor to the AMSR on the Advanced Earth Observation Satellite-II (ADEOS-II) and the Advanced Microwave Scanning Radiometer for EOS (AMSR-E) on the Aqua satellite. The sensor takes measurements at multiple frequencies and multiple polarizations of weak electromagnetic waves in the microwave band radiated from the Earth's surface and the atmosphere. It is designed to estimate a variety of geophysical parameters, particularly those connected to water.

AMSR2 will continue AMSR/AMSR-E global observations with high spatial resolution and at multiple frequencies and multiple polarizations, including low frequency channels. This will enable the creation of long-term trustworthy data sets (including sea ice concentrations, sea surface temperatures, sea surface wind speeds, water vapor content, precipitation, and marine flux) that will help us understand, monitor, and predict climate changes.

2.1 Overview of GCOM-W1

GCOM-W1, the first satellite of the GCOM-W series, carries AMSR2, the mission-critical device that supplants AMSR-E. The satellite unit has the following reliability and survivability characteristics to ensure it can definitely execute its development and mission.

Reliability and survivability

- (1) The design is highly reliable with redundant systems for nearly every onboard device.
- (2) The satellite's survivability has been increased in the event that one of the two solar paddles fails by equipping it with a graceful degeneracy mode so that the satellite can operate on reduced power.
- (3) In preparation for on-orbit contingencies, the satellite is equipped with autonomous functions in which the satellite autonomously makes various controls while on orbit.
- (4) Highly reliable devices and components were selected based on on-orbit performance in past satellites. Furthermore, costs have been kept down by using a common bus design for GCOM-W1 and GCOM-C1, the first generation of GCOM-C series satellites that will be launched after GCOM-W1.

Accessibility and serviceability

- (5) The satellite bus consists of the bus module, mission module, and propulsion module. The satellite bus's structure is such that the three modules can be developed and serviced in parallel. Even after assembly, the propulsion module can be dismantled from the satellite bus module relatively easily for better accessibility and serviceability.

Figure 2-1 provides exterior views of GCOM-W1, and Table 2-1 lists its main specifications.

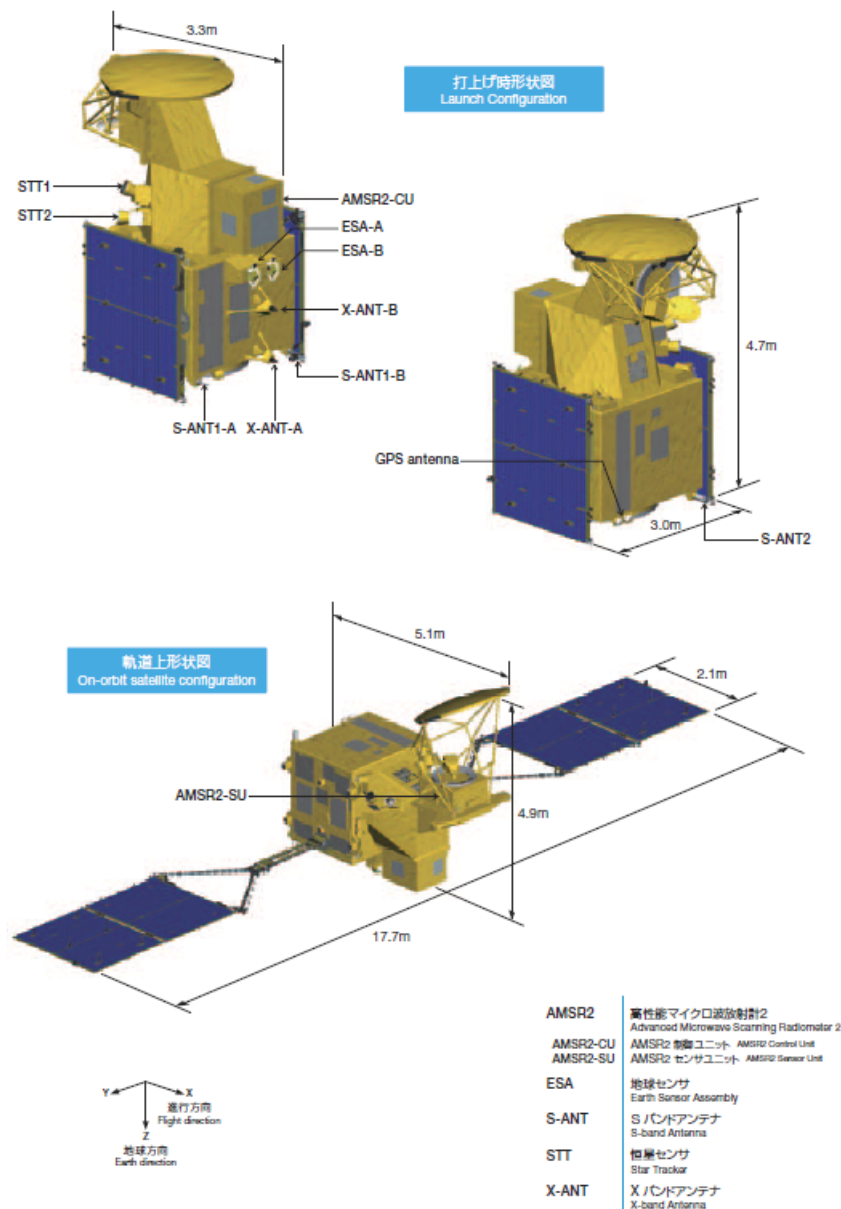

Figure 2-1: Exterior views of GCOM-W1

Table 2-1: Main GCOM-W1 specifications

Launch	Launch vehicle	H-IIA
	Launch site	Tanegashima Space Center
	Launch timing	FY 2012
Orbit	Sun-synchronous sub-recurrent orbit (frozen orbit)	
	Altitude (above the equator)	699.6 km
	Inclination	98.186°
	Local sun time at ascending node	13:30 ± 15 min.
Weight	Launch mass	1991 kg max. (including the propellant)
Shape	Box shape with two solar array paddles	
	Satellite body section	Approx. 2.2 x 2.1 x 1.8 m
	Solar array paddle	Approx. 7.7 x 2.1 m
	AMSR2 (after deployment)	Approx. 2.2 x 4.9 x 2.0 m
Life	Design life	5 years
	Probability of survival	0.8 min., 5 years after launch
Power generated	3,880 W min. (end of life)	
Mission equipment	Advanced Microwave Scanning Radiometer 2	

2.2 Advanced Microwave Scanning Radiometer 2 (AMSR2)

AMSR2 was developed to be the successor to AMSR on the ADEOS-II and AMSR-E on NASA's Aqua Earth observation satellite. AMSR2's antenna diameter has been enlarged to 2.0 meters from the AMSR-E's 1.6 meters to give a higher spatial resolution. For more accurate observations, a new 7.3 GHz channel has been added to eliminate electromagnetic-wave interference, and the calibration system has been upgraded for better calibration accuracy.

The objective of the GCOM mission is long-term observations over a 10-year to 15-year span through three generations of satellites. After the first-generation's

AMSR2, successors to the AMSR2 are planned to be developed for the second and third generation satellites.

Figure 2-2 provides exterior views of AMSR2, Table 2-2 lists its main specifications, and Table 2-3 compares the AMSR series' sensors.



Figure 2-2: Exterior view of AMSR2

Table 2-2: Main AMSR2 specifications

観測周波数 Observation Frequency [GHz]	6.925	7.3	10.65	18.7	23.8	36.5	89.0(A)	89.0(B)
帯域幅 Band Width [MHz]	350	350	100	200	400	1000	3000	3000
偏波 Polarization	H/V							
温度分解能 Temperature Resolution [K]	0.34	0.43	0.7	0.7	0.6	0.7	1.2	1.2
ダイナミックレンジ Dynamic Range [K]	2.7~340							
オフナディア角 Off-Nadir Angle [deg]	47.5							
観測幅 Swath Width [km]	1450							
走査周期 Scan Period [sec]	1.5±1% (40rpm)							
ビーム幅 Beam Width [deg]	1.8	1.8	1.2	0.65	0.75	0.35	0.15	0.15
瞬時視野 IFOV (Az × El) [km]	35×62	34×58	24×42	14×22	15×26	7×12	3×5	3×5
ビーム効率 Beam Efficiency [%]	>90							
サンプリング間隔 Sampling Interval [km]	10						5	

Table 2-3: AMSR series comparisons

Sensor	AMSR	AMSR-E	AMSR2
Operation dates	Dec. 14, 2002 to Oct. 25, 2003	May 4, 2002 to Oct. 4, 2011	From May 18, 2012 on
Satellite	ADEOS-II	Aqua	GCOM-W1
Major performance changes from previous AMSR series sensors	n/a	<ul style="list-style-type: none"> Reduced the antenna diameter (from 2.0 meters to 1.6 meters) due to limitations of the payload faring, used an antenna expansion deployment method, and eliminated the 50 GHz band channels 	<ul style="list-style-type: none"> Enlarged the deployed antenna diameter to 2 meters to boost spatial resolution Upgraded the calibration system for more reliable calculations of brightness temperatures Added a 7.3 GHz band channel to lower interference from terrestrial radio signals
Observation frequencies (GHz)	Spatial resolution (km)		
6.925	40 x 70 (HV)	43 x 75 (HV)	35 x 62 (HV)
7.3	—	—	35 x 62 (HV)
10.65	27 x 46 (HV)	29 x 51 (HV)	24 x 42 (HV)
18.7	14 x 25 (HV)	16 x 27 (HV)	14 x 22 (HV)
23.8	17 x 29 (HV)	18 x 32 (HV)	15 x 26 (HV)
36.5	8 x 14 (HV)	8.2 x 14.4 (HV)	7 x 12 (HV)
50.3	6 x 10 (V)	—	—
52.8	6 x 10 (V)	—	—
89 (A channel)	3 x 6 (HV)	3.7 x 6.5 (HV)	3 x 5 (HV)
89 (B channel)	3 x 6 (HV)	3.5 x 5.9 (HV)	3 x 5 (HV)

Note: HV: horizontal and vertical polarization, V: vertical polarization

AMSR2 consists of a sensor unit — essentially a rotating scanner — and a fixed control unit as well as a momentum wheel B system carried by the satellite mission chassis. The AMSR2's antenna unit that picks up microwaves from Earth rotates once every 1.5 seconds, creating a conical scan pattern covering a width of about 1,450 kilometers on the Earth's surface each rotation. This scanning method can make one day and one night observation of more than 99 percent of the Earth's surface in two days. During one rotation, the sensor collects surface observation data over a ± 61 degree range centered on the flight direction and calibrator data (from a high-temperature noise source and a cold sky mirror) at all other angles. The high-temperature noise source is a microwave absorber temperature controlled to about 300 Kelvin, and the cold sky mirror is a reflector oriented toward deep space. The data obtained from these two measurements are used for two-point calibration purposes. The scanning rotational speed must be kept constant to collect in sequence low-temperature calibration data, surface observation data, and high-temperature calibration data at the correct rotational angles. The rotational speed is controlled using feedback from a speed signal from the rotational drive unit.

Furthermore, a momentum wheel offsets the large angular momentum that the scanning unit produces. The momentum wheel's rotational speed is controlled to track the scanning unit's angular momentum and its design is such that the angular momentum has no effect on the overall satellite system.

2.2.1 AMSR2: Principle of Operation

AMSR2 is a microwave scanning radiometer that captures both horizontally and vertically polarized near-surface radiation brightness data as antenna equivalent noise temperatures in seven frequency bands, ranging from the 6.9 GHz band to the 89 GHz band.

Figure 2-3 illustrates how the AMSR2 operates once in orbit. The AMSR2 sensor unit is located at the satellite's forward apex and rotates counterclockwise about the Z-axis while in flight, creating a conical scan pattern in which the antenna beam transcribes an arc of approximately 1,660 kilometers in diameter on the Earth's surface.

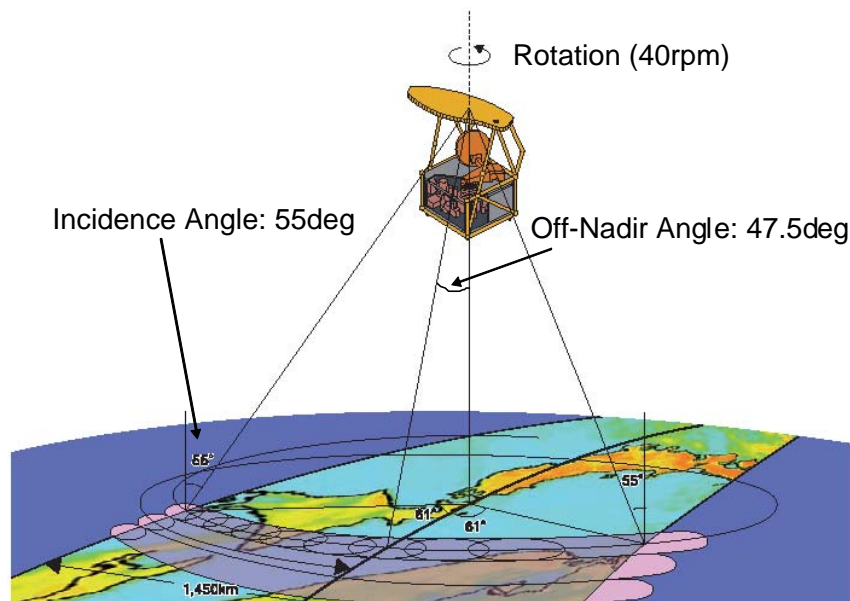

Figure 2-3: AMSR2: Principle of operation

The antenna beam maintains an off-nadir angle of 47.5 degrees with the Z-axis, resulting in an incidence angle of 55 degrees at the Earth's surface due to the Earth's curvature.

Because microwave scanning radiometry is strongly dependent on the incidence angle, favorable characteristics were assured by employing a conical scan pattern with a constant surface incidence angle independent of the observation point. The 55-degree incidence angle was selected because this angle is fairly immune to the effects of sea surface winds and because it produces a large differential between horizontally and vertically polarized signals.

The signal processor is specified to capture surface observation data over an angular sector of more than ± 75 degrees about the satellite's X-direction. Not all of this data is valid, however, due to main beam interference by the high-temperature noise source and cold-sky mirror. The design ensures an interference-free angular sector between -61 degrees and +58 degrees in the 6.9 GHz band and between ± 61 degrees in the other frequency bands. Consequently, valid surface observation data are the data captured within the scanning arc of ± 61 degrees about the X-direction. This provides a 1450-kilometer observation swath of the Earth's surface.

To achieve a 10-kilometer sampling interval along the satellite's track, the nominal conical scan period is set to 1.5 seconds, so that the sensor unit rotates once every 10 surface kilometers travelled, given the ground speed of the GCOM-W1, which has a flight altitude of 700 kilometers. The 1.5-second scan period corresponds to a

rotational speed of 40 rpm. And to ensure a sampling interval of 10 kilometers in the scanning direction, the sampling period (integration period) in the scanning direction is set to 2.6 milliseconds.

The 89 GHz band, however, has a separate beam with an offset between the two channels of approximately 15 kilometers about the sub-satellite track. Therefore, a nominal sampling interval along the sub-satellite track of 5 kilometers is used to match up data every three rotations. Furthermore, setting the sampling period in the scanning direction to 1.3 milliseconds gives a nominal sampling interval of 5 kilometers in the scanning direction.

The antenna beam's instantaneous field of view (IFOV) (footprint, defined as the half-power (3 dB) beam-width) projects as an ellipse on the Earth's surface with its major axis along the sub-satellite track. Because the antenna's effective aperture size is 2.0 meters in diameter, its IFOV is approximately 3 km x 5 km (along scan x along track) in the 89 GHz band. Furthermore, the spatial resolution (distance between pixel centers) is the measurement of an area approximately 10 kilometers long in the scanning direction at an integration period of approximately 2.6 milliseconds (1.3 milliseconds for the 89 GHz band). Underlapping is the condition when no overlap occurs between scan lines or between adjacent pixels in the scan line direction. AMSR2 is designed to ensure no underlapping occurs.

To observe seven frequency bands, the antenna unit contains six primary radiometers (feed horns) arranged in a row. Because the beam axis of each radiometer points at a different part of the main reflector, the angle necessary to point each beam simultaneously at the surface from the main reflector is different for each frequency. Therefore, the feed horns for each frequency are spaced apart in the direction of the sub-satellite track so that the beam axis of each frequency and each polarization travels along the identical scan line. Furthermore, the measurement for each frequency occurs at a slightly different time to compensate for displacements in the scanning direction. In this way, the design ensures the footprint for each frequency measures the identical point on the Earth's surface. The relative positional differences in footprints between frequencies are part of the frequency registration.

2.2.2 System Architecture and External Appearance

AMSR2 consists of a sensor unit and a control unit. This section describes AMSR2's system architecture and external appearance.

2.2.2.1 System architecture

Table 2-4 lists the subsystems and components that make up AMSR2.

Table 2-4: AMSR2 architecture

Unit	Component	Abbreviation	Primary Functions
Sensor unit (SENS UNIT)	Antenna	ANT	Directs microwave emissions from the Earth to the receiver.
	Calibrator	CAL	Consists of a cold sky mirror and a high-temperature noise source to make temperature calibrations of observation data.
	Receiver	RX	After passing the microwaves from the antenna through a low-noise amplifier, the receiver applies bandwidth filtering to the signal to pass only the observation bandwidth, followed by additional amplification, demodulation, and integration, before outputting the signal to the signal processor sensor unit. The receiver also performs temperature monitoring needed for observation data calibration.
	Antenna drive assembly (Antenna drive mechanism)	ADA (ADM)	Rotates the AMSR2's antenna, receiver, and other components at a constant angular speed.
	Signal processor sensor unit	SPS	Performs A/D conversions of observation data from the receiver units, controls calibration of the receiver, controls components in the sensor unit according to commands from the SPC, obtains telemetry data from within the sensor, and outputs signals to the SPC.
	Thermal controller sensor unit	TCS	Performs thermal controls within the sensor unit based on commands from the SPS.
	Power distributor unit sensor unit	PDUS	Acts as the power-supply interface with the PDUC and distributes power to all the sensor unit components.
	Disturbance controller (Orbital balancing mechanism/Orbital balancing electronics)	OBM/OBE	Regulates the mass balance of the sensor unit's rotation part in orbit.
	Sensor unit structure	STRS	Securely fastens the sensor unit components in place.
	Deployment mechanism	DEP	Stows the antenna's main reflector during the launch phase and deploys the main reflector on orbit.
Integrator unit	-	Electrically and mechanically integrates the components.	
Control unit (CONS UNIT)	Antenna drive assembly (Antenna drive electronics)	ADA (ADE)	The drive mechanism (motor, bearings, etc.) that calibrates the antenna drive mechanism is located in the sensor unit, and the antenna drive electronics are housed in the control unit.
	Signal processor control unit	SPC	Adds satellite telemetry and other telemetry data to the observation data and telemetry data from the SPS, edits the data into a preset format, and outputs them to the satellite system. Receives commands from the satellite system and controls components in the control unit and sends sensor unit commands to the SPS. It also controls the rotation / disturbance response of the ADA and MWA.
	Thermal controller control unit	TCC	Performs thermal controls within the control unit based on commands from the SPC.

Unit	Component	Abbreviation	Primary Functions
	Power distributor unit control unit	PDUC	Acts as the primary power-supply interface with the satellite system and distributes power to the control unit and the PDUS.
	Momentum wheel assembly	MWA	To offset the angular momentum generated by the scanning rotation, the momentum wheel assembly rotates in the opposite direction to the scanner unit with same angular momentum.
	Control unit structure	STRC	Securely fastens the control unit components in place.
	Integrator unit	-	Electrically and mechanically integrates the components.

2.2.2.2 External appearance

Figure 2-4 provides an external view of AMSR2.

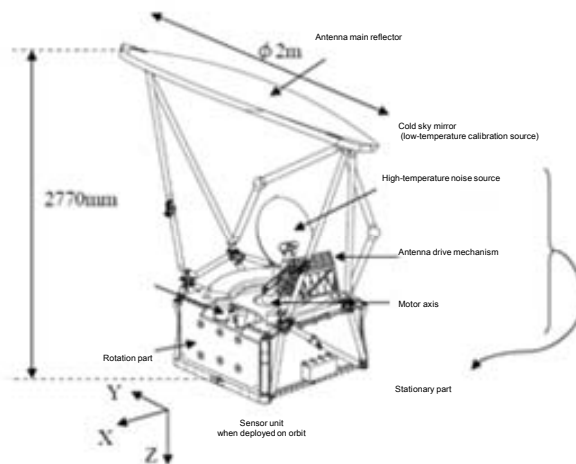

Figure 2-4: Exterior schematic of AMSR2

2.2.3 Component Descriptions

This section describes the structure, primary functions, and performance of each AMSR2 component. Note that specification values are given for the performance values listed here. These values may be revised later through equipment verifications after launch.

2.2.3.1 Antenna

(1) Structure

The AMSR2 antenna consists of a main reflector and a feed-horn assembly. The feed-horn cluster consists of a shared 6/7 GHz horn, a 10 GHz horn, a shared 18/23 GHz horn, a 36 GHz horn, and two 89 GHz band horns. It also has polarization splitters for separating vertical and horizontal polarized waves. Note

that the splitters in the shared 6/7 GHz and 18/23 GHz feed horns are equipped with band-rejection filters and high-pass filters to separate both frequencies.

(2) Functions

The primary functions of the antenna are as follows:

- a. Direct microwave emissions from the Earth to the receiver.
- b. Maintain a beam width that can deliver the required spatial resolution.
- c. Maintain a beam efficiency that can deliver sufficient observation accuracy.
- d. Separate vertical polarized waves and horizontal polarized waves and direct each to the receiver for each polarization.

(3) Performance

Table 2-5 lists the antenna's main performance values.

Table 2-5: Main performance values of the antenna

Parameter	Performance Value							
Center frequency [GHz]	6.925	7.3	10.65	18.7	23.8	36.5	89.0 (A)	89.0 (B)
Bandwidth [MHz]	350	350	100	200	400	1000	3000	3000
Beam width [deg.]	1.8	1.8	1.2	0.65	0.75	0.35	0.15	0.15
Cross polarization	No more than -20dB							
Main beam efficiency	No less than 90%							
Polarization	Vertical and horizontal							
No. of feed horns	1	1	1	1	1	1	1	1

2.2.3.2 Calibrator

(1) Structure

To calibrate observation data, the AMSR2 calibrator consists of a cold sky mirror (CSM), which captures the brightness temperature of deep space (approximately 2.7 Kelvin) and a high-temperature noise source (HTS), which is controlled to

approach the ambient temperature.

(2) Functions

The primary functions of the calibrator are as follows:

- a. The high-temperature noise source (HTS) is a microwave absorber with a constant temperature that emits microwaves used as the calibration reference that are fed into the feed-horn assembly.
- b. The cold sky mirror (CSM), used for low-temperature calibration, directs microwave background emissions from deep space (at 2.7 Kelvin) into the feed-horn assembly.

(3) Performance

Table 2-6 and Table 2-7 list the main performance values of the HTS and CSM respectively.

Table 2-6: Main performance values of the HTS

Parameter	Performance Value						
Center frequency [GHz] (nominal)	6.925	7.3	10.65	18.7	23.8	36.5	89.0
Bandwidth [MHz] (nominal)	350	350	100	200	400	1000	3000
Reflection characteristics	No more than -30dB						
Temperature control range	$20^{\circ}\text{C} \pm 10^{\circ}\text{C}$						
Variance in surface temperature distribution	No more than $2.5^{\circ}\text{C}_{\text{p-p}}$						
Temperature measurement accuracy	Bias component 0.3°C Random component: within 0.4° (3σ) (within 0.1° is the target) (The platinum sensor itself, temperature differences between the microwave absorber's surface temperature and the temperature sensor, and errors in the temperature measurement circuit)						
Temperature measurement range	-35°C to $+35^{\circ}\text{C}$						
Polarization	Vertical and horizontal						

Table 2-7: Main performance values of the CSM

Parameter	Performance Value						
Center frequency [GHz] (nominal)	6.925	7.3	10.65	18.7	23.8	36.5	89.0
Bandwidth [MHz] (nominal)	350	350	100	200	400	1000	3000
Reflector shape	Offset parabola						
Beam width	No more than 10 degrees						
Polarization	Vertical and horizontal						

2.2.3.3 Receiver

(1) Structure

The AMSR2 receiver has independent receiver units for each horizontal polarized wave and vertical polarized wave at each observation frequency.

(2) Functions

The primary functions of the receiver are as follows:

- a. After passing the microwaves from the antenna through a low-noise amplifier, the receiver applies bandwidth filtering to the signal to pass only the observation bandwidth, followed by additional amplification, demodulation, and integration, before outputting the signal to the signal processor sensor unit.
- b. The receiver also performs temperature monitoring needed for observation data calibration.
- c. It has auto gain control (AGC), which adjusts the gain according to control signals from the signal processor sensor unit.
- d. The receiver has a DC/DC converter that provides a voltage reference to stabilize the primary power source.

(3) Performance

Table 2-8 lists the receiver's main performance values.

Table 2-8: Main performance values of the receiver

Parameter	Performance Value						
Center frequency [GHz]	6.925	7.3	10.65	18.7	23.8	36.5	89.0
IF center frequency [GHz]	-	-	2.5	2.5	2.2	2.5	4.5
Bandwidth [MHz]	350	350	100	200	400	1000	3000
Noise factor [dB]	1.25	2.0	1.52	2.30	2.70	4.40	6.70
Integration period [ms]	2.6						1.3

2.2.3.4 Antenna drive assembly

(1) Structure

The AMSR2 antenna drive assembly consists of the antenna drive mechanism and the antenna drive electronics. The antenna drive mechanism consists of the following main components. Note that the antenna drive electronics are housed in the control unit.

- 1.Motor
- 2.Bearings
- 3.Slip ring
- 4.Encoder
- 5.Commentator

(2) Functions

The primary functions of the antenna drive assembly are as follows:

- a. Make conical scans of the Earth's surface by rotating the AMSR2 antenna, receiver, and other components at a constant angular speed.
- b. The fixed axle's bearings support the rotation part of the sensor unit.
- c. It has a slip ring and related parts in order to pass power and signals bidirectionally between components in the rotation part of the sensor unit and components in the stationary part.
- d. The encoder functions to monitor the angular position and speed of the rotation part.

(3) Performance

Table 2-9 lists the antenna drive assembly's main performance values.

Table 2-9: Main performance values of the antenna drive assembly

Parameter	Performance Value	Remarks
Scanning angular speed	40 rpm \pm 1% (for nominal observations)	The functionality exists to obtain correct observation data and calibration data for rotational speeds anywhere between 30 rpm and 40 rpm.
Direction of rotation	Rotates counterclockwise about the +Z axis	

2.2.3.5 Signal processor

(1) Structure

The AMSR2 signal processor consists of the signal processor sensor unit (SPS) and the signal processor control unit (SPC). The SPS contains the disturbance controller's electronic circuitry. The SPC and its interface have a redundant structure.

(2) Functions

The primary functions of the signal processor are as follows:

- a. Performs A/D conversions of observation data from the receiver units, edits calibration data and telemetry data into a preset format, and outputs them to the satellite system.
- b. Controls the receiver gain and controls the offset.
- c. Controls the receiver's integrator discharge timing and the receiver's hold timing.
- d. Measures the temperature of the sensor unit and control unit.
- e. Processes commands from the satellite system and sends them to other AMSR2 components. Also edits telemetry data collected from other AMSR2 components and sends them to the satellite system.
- f. It has a DC/DC converter that it provides a voltage reference to stabilize the primary power source.

(3) Performance

Table 2-10 lists the signal processor's main performance values.

Table 2-10: Main performance values of the signal processor

Parameter	Performance Value
A/D conversion resolution of receiver signals	12 bit
No. of temperature sensor channels	SPS: 46 channels SPC: 31 channels
Temperature measurement cycle	1.5 seconds (during regular observations)

2.2.3.6 Thermal controller

(1) Structure

The AMSR2 thermal controller consists of the thermal controller sensor unit (TCS) and the thermal controller control unit (TCC).

(2) Functions

The primary functions of the thermal controller are as follows:

- a. The TCS controls the temperature within the sensor unit with an on/off control in response to commands from the signal processor sensor unit.
- b. The TCC controls the temperature within the control unit and the sensor unit with an on/off control in response to commands from the signal processor control unit.

2.2.3.7 Power distribution unit

(1) Structure

The AMSR2 power distribution unit consists of the power distribution unit sensor unit (PDUS) and the power distribution unit control unit (PDUC).

(2) Functions

The primary functions of the power distribution unit are as follows:

- a. The PDUS acts as the interface with the PDUC and distributes power to all the sensor unit components. It also has a capacitor bank.
- b. The PDUC acts as the primary power-supply interface with the satellite system and distributes power to the AMSR2 control unit and the PDUS. It also has a capacitor bank.

(3) Performance

Table 2-11 lists the power distribution unit's main performance values.

Table 2-11: Main performance values of the power distribution unit

Parameter	Performance Value
Max. distributed power	Sensor unit: no less than 533 W Control unit: no less than 900 W

2.2.3.8 Disturbance controller

(1) Structure

The AMSR2 disturbance controller consists of the disturbance controller sensor unit and the disturbance controller control unit. The disturbance controller sensor unit consists of the orbital balancing mechanism (OBM) and the orbital balancing electronics (OBE), and the disturbance controller control unit consists of the momentum wheel and the momentum wheel control circuit. The disturbance controller electronics are contained in the signal processor control unit.

(2) Functions

The primary functions of the disturbance controller are as follows:

- a. To offset the angular momentum generated by the scanning rotation, the disturbance controller's momentum wheel assembly rotates in the opposite direction to the scanner unit with the same angular momentum.
- b. The active OBM regulates the mass balance of the sensor unit's rotation part when in orbit.
- c. The momentum wheel and the OBM are controlled with commands from the satellite system.
- d. The controller runs up and runs down the rotation as necessary so as to minimize any influence on the satellite's attitude.

2.2.3.9 Deployment mechanism

(1) Structure

The AMSR2 deployment mechanism consists of the following main components:

1. Supports
2. Hinges
3. Joints
4. Damper

5. Latch

(2) Functions

The primary function of the deployment mechanism is as follows:

- a. Stows the antenna's main reflector during the launch phase and deploys the main reflector on orbit.

(3) Performance

The primary performance values of the deployment mechanism are as follows:

- a. Has sufficient torque to deploy the antenna's main reflector on orbit.
- b. Is able to maintain the prescribed alignment accuracy after deployment of the antenna's main reflector.

2.2.4 Operational Modes

2.2.4.1 Mode definitions

AMSR2 has six operational modes, as described below.

(1) Science Mode

In this mode, AMSR2 collects and edits observation data and outputs the data as mission data to the satellite. All devices are on, including the receivers. In the Observation Mode, mission data and HK telemetry data are output to the satellite. This mode includes a standby state that starts after the heater for the receivers and the high-temperature noise source (HTS) is turned on and that continues until the start of observation data collections.

(2) Safe 1 Mode

In this mode, observations are stopped. The antenna drive mechanism (ADM) and the momentum wheel assembly (MWA) continue to rotate at the regular angular speed. The receiver's power supply is on, and the thermal settings are active to maintain all devices within their permitted temperature ranges. AMSR2 transitions from the Science Mode to this mode in response when the satellite goes into its Safe Mode.

(3) Survival Mode

In this mode, devices are maintained within their operating temperature ranges. The ADM and the MWA are stopped, and the survival thermal settings are active to

maintain all devices within their permitted temperature ranges. In this mode, the signal processor handles only telemetry data and command processing.

(4) Off Mode

In this mode all devices are off. This mode is active when launching, when deploying the antenna, and when releasing the sensor unit.

(5) Run Up

This mode runs up the rotational speed of the ADM and the MWA from a stationary state to the regular rotational speed. AMSR2 remains in this mode until a stable rotation is achieved. The acceleration behavior and a series of operations and states, such as thermal setting switchovers, after the ADM heater is turned on are used as the acceleration reference.

The rotational speed is increased in a number of stages to keep the resulting disturbance to the satellite within the permissible range. Where necessary, the MWA rotational speed is corrected and the sensor unit's mass balance is adjusted with the OBM. Note that the ADM's regular rotational speed is 40 rpm, and the MWA's regular rotational speed is approximately 2,000 rpm (when two wheels are in operation).

(6) Run Down

This mode runs down the rotational speed of the ADM and the MWA from the regular rotational speed to a stationary state. The deceleration is regulated by the deceleration behavior and a series of operations and states, such as thermal setting switchovers. In normal on-orbit operation of AMSR2, this mode is not used.

2.2.4.2 Mode transitions

AMSR2 is launched in the All Off Mode, and the Survival Mode maintains device temperatures until antenna deployment and sensor unit release. During antenna deployment and sensor unit release, it goes into the All Off Mode, which shuts down all devices temporarily, after which percussion caps trigger the deployment and release.

AMSR2 moves into the Survival Mode after antenna deployment and sensor unit release and then commences the run-up according to the run-up schedule. When necessary, the OBM adjusts the sensor unit's mass balance during the run-up. Once the ADM and the MWA reach their regular rotational speeds, AMSR2 moves first into the Sleep Mode and then finally into the Normal Mode by powering on the

receivers and making the Normal Mode thermal settings.

Figure 2-5 illustrates the AMSR2 mode transitions after antenna deployment and sensor unit release.

Note that AMSR2, in regular operation, runs in Normal Mode, in which normal observations are made. It can, when necessary, transition into the Sleep Mode, Run Down Mode, or Survival Mode.

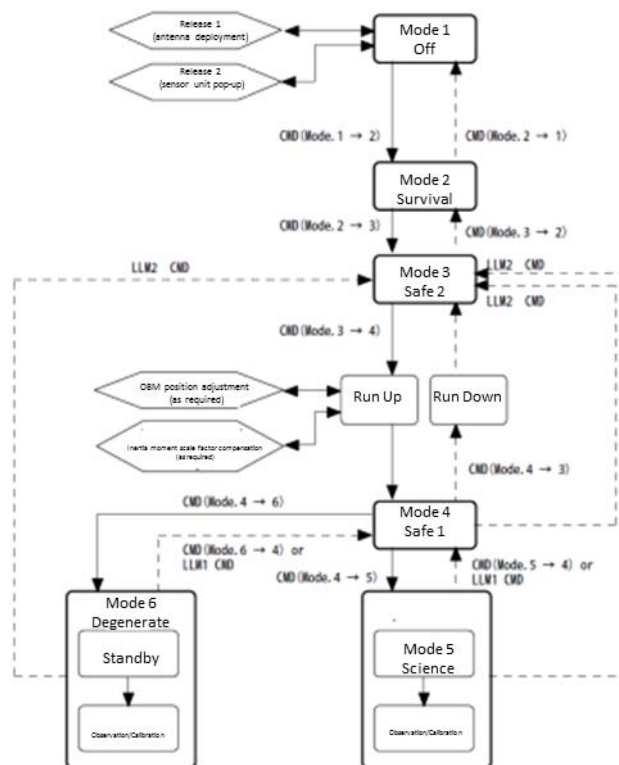

When an LLM command is received while the disturbance system is processing an anomaly, the disturbance system's anomaly processing sequence is given priority.

Figure 2-5: AMSR2 mode transitions

2.2.5 Radiometric Performance

2.2.5.1 Observation frequencies and polarizations

The AMSR2 observation frequencies and polarizations are as given in Table 2-2. The main difference from AMSR-E is the addition of the 7.3 GHz frequency, which is intended to reduce radio-frequency interference.

2.2.5.2 Main beam efficiency

The main beam efficiency is the fraction of the total desired polarized energy received within an angle 2.5 times the beam width. The main beam efficiency is

expressed as an average value within a given observation band. The design requirement for AMSR2 is a main beam efficiency of no less than 90 percent in all observation frequency bands.

2.2.5.3 Temperature resolution

Table 2-12 gives the temperature resolution for each AMSR2 observation frequency band.

Table 2-12: AMSR2 temperature resolutions (specification values)

Center Frequency [GHz] (nominal)	Temperature Resolution [K]
6.925	No more than 0.34 (target is no more than 0.3)
7.3	No more than 0.43
10.65	No more than 0.7 (target is no more than 0.6)
18.7	No more than 0.7 (target is no more than 0.6)
23.8	No more than 0.6 (target is no more than 0.55)
36.5	No more than 0.7 (target is no more than 0.65)
89.0	No more than 1.2 (target is no more than 1.1)

2.2.5.4 Dynamic range

The AMSR2 dynamic range is 2.7 to 340 Kelvin. The dynamic range is maintained by adjusting the gain / offset of receivers so that the high-temperature and low-temperature calibration outputs are contained within the given output range.

2.2.5.5 Linearity

The AMSR2 linearity (specification value) is ± 1 percent (RMS).

2.2.6 Calibration

AMSR2 collects low-temperature and high-temperature calibration data each 1.5-second scanning cycle that are used to correct receiver gain fluctuations. Figure 2-6 provides an exterior view of the CAL in order to show the positional

relationship of the high-temperature noise source (HTS) and the cold sky mirror (CSM).

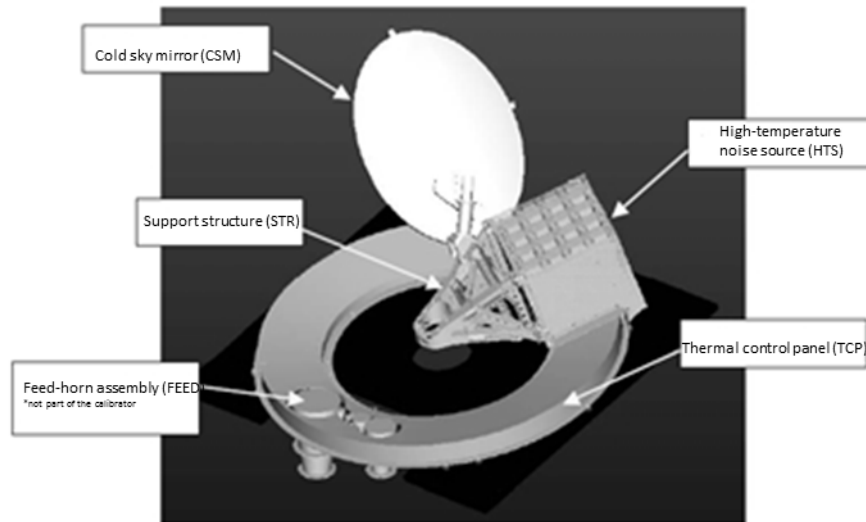

Figure 2-6: Exterior view of the CAL

2.2.6.1 Low-temperature calibration

Low-temperature calibration takes place by observing deep space (with a brightness temperature of 2.7 Kelvin) using a cold sky mirror (CSM). The calibration brightness temperature, however, rises above 2.7 Kelvin due to the effect of receiving radiation other than deep space background radiation.

There are many error factors affecting the low-temperature calibration brightness temperature: Earth radiation, moon radiation, radio frequency interference from stationary satellites, solar contamination, radiation from the satellite structure itself, and Earth radiation projecting on the main reflector. The largest of these are Earth radiation, moon radiation, radio frequency interference, and solar effects. These errors are corrected in the Level 1A processing stage.

2.2.6.2 High-temperature calibration

High-temperature calibration takes place by observing the high-temperature noise source (HTS), a microwave absorber that is controlled at a temperature of 300 Kelvin.

The high-temperature calibration brightness temperature may contain errors due to HTS non-uniformities or discrepancies with the platinum sensor measurement temperature. These errors are corrected in the Level 1A processing stage. (See Section 4.2.1.)

2.2.7 Geometric Performance

The AMSR2's geometric performance must be gauged by accounting for the performance of numerous factors, including the off-nadir angle, the Earth incidence angle, the scanning arc, the observation swath, the beam width associated with the instantaneous field of view, the footprint — which considers the instantaneous field of view and the integration period, and the pointing.

2.2.7.1 Off-nadir angle and Earth incidence angle

The off-nadir angle and the Earth incidence angle are two geometrical parameters related to the Earth's curvature and the satellite's altitude. In the AMSR2's hardware design, these parameters are dependent on the design of the beam direction relative to the AMSR2's coordinate axis. Figure 2-7 illustrates the relationship of these parameters.

For the AMSR2's design, the flight altitude is assumed to be 700 kilometers and the Earth's radius is assumed to be 6,378 kilometers. The off-nadir angle is set to give an Earth incidence angle of 55 degrees. These factors result in a nominal off-nadir angle of 47.5 degrees.

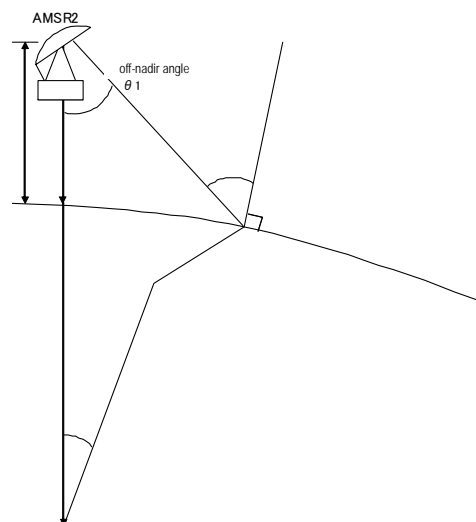

Figure 2-7: Illustration of AMSR2's geometric performance (off-nadir and incidence angle)

For the 89 GHz band, however, the sensor uses two beams, 89 GHz A and 89 GHz B, with a nominal offset of 15 kilometers along the sub-satellite track. Setting the 89 GHz B beam's off-nadir angle to 47.0 degrees gives a nominal offset between 89 GHz A and 89 GHz B of 14.98 kilometers on the Earth's surface. The change in the off-nadir angle produces a nominal incidence angle of 54.5 degrees for the 89 GHz

B beam.

Note that AMSR2 uses a method by which six feed horns simultaneously use the main reflector, as shown in Figure 2-8. The orientation and position of each feed horn is offset geometrically to give a sensor off-nadir angle of 47.5 degrees.

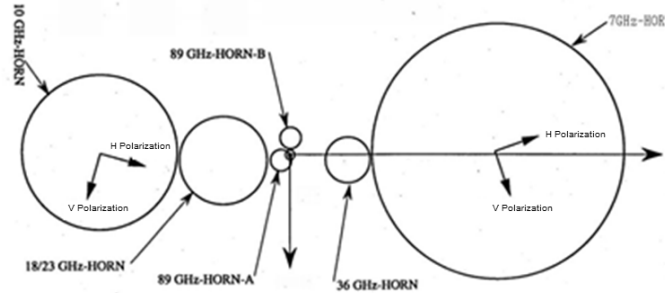

Figure 2-8: Layout of the feed-horn assembly

2.2.7.2 Scanning arc and observation swath

With the AMSR2's off-nadir angle set to 47.5 degrees, the movable portion that includes the antenna rotates counterclockwise about the Earth-center axis (the Z-axis) to produce a conical scan pattern in which the beam center, as seen relative to the AMSR2's stationary part, transcribes an arc 1,660 kilometers in diameter on the Earth's surface.

When a scanning arc of ± 61 degrees about the sub-satellite track (X-axis) is maintained, a nominal observation swath of 1,450 kilometers can be guaranteed as the Earth projection swath covered by the scanning arc.

To ensure this scanning arc, the requirements on the AMSR2's hardware design are: (1) there are no obstacles in the main beam's path between the feed horns and the main reflector and between the main reflector and the Earth surface, and (2) the signal processor captures and processes data that wholly contains the prescribed scan arc.

The design ensures the main beam is interference-free over an angular sector between -61 degrees and +58 degrees in the 6.9 GHz band and between ± 61 degrees in the other frequency bands. Furthermore, the signal processor is specified to capture observation data over an angular sector of more than ± 75 degrees. By meeting both requirements, the scanning arc is sufficiently ensured.

Even though some field-of-view interference is expected in the +58 degree to +61 degree range in the 6.9 GHz band, no problems are expected in terms of gain, beam efficiency, cross polarization, or signal strength. Therefore, the design ensures an effective scanning arc of no less than ± 61 degrees and an observation

swath of no less than 1,450 kilometers for all frequencies.

2.2.7.3 Rotational speed, scan period, and sampling interval

The rotational speed, scan period, and sampling interval are related through the AMSR2's geometric imaging principles. The sampling interval in the flight direction corresponds to the distance traveled on the surface along the sub-satellite track during the time (the scan period) between two consecutive data captures by the AMSR2's rotation part when rotating at a constant rotational speed. Figure 2-9 illustrates this relationship.

Assuming a flight altitude of 700 kilometers and an Earth radius of 6,378 kilometers, the GCOM-W1 ground speed is 676 kilometers per second. If the AMSR2's rotational part rotates at a nominal speed of 40 rpm, a scan period of 1.5 seconds corresponds exactly to one revolution, resulting in a nominal sampling interval in the flight direction of 10.14 kilometers.

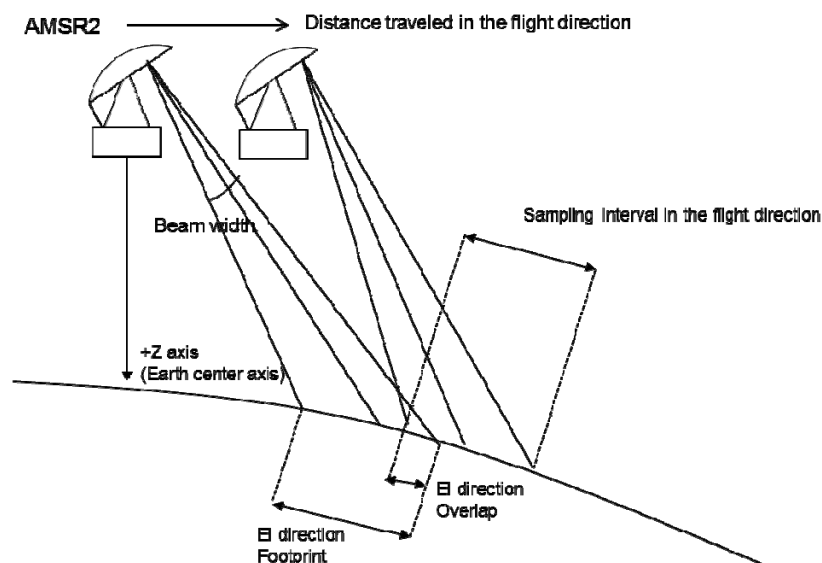

Figure 2-9: Illustration of AMSR2's geometric performance (sampling interval, beam width, footprint, and overlap)

2.2.7.4 Sampling period, integration period, and sampling interval

The AMSR2's beam center transcribes an arc 1,660 kilometers in diameter on the Earth's surface. Given that the AMSR's rotational part rotates at a nominal 40 rpm, setting the sampling period to 2.6 milliseconds gives a nominal sampling interval in the scanning direction of 8.87 kilometers. The sampling period for the 89 GHz band is set to 1.3 milliseconds, resulting in a nominal sampling interval in the scanning

direction of 4.44 kilometers.

2.2.7.5 Beam width and footprint

The beam width is set based on the antenna characteristics. Table 2-13 gives the beam width design values for the antenna.

The main beam's shape and distance on the Earth surface (called the "footprint") are dependent on the flight altitude, the off-nadir angle, and the beam width. The footprint's shape is determined by the Earth's curvature.

As Figure 2-9 indicates, the footprint in the flight direction is determined geometrically as the Earth incidence arc between the upper and lower limits of the beam width in the flight direction. Table 2-13 also lists the footprint corresponding to the nominal beam width assuming a flight altitude of 700 kilometers and an Earth radius of 6,378 kilometers.

Table 2-13: Beam width and footprint

Center Frequency	Beam Width (nominal)	Footprint (along scan x along track)	Remarks
6.925 GHz	1.8° ± 15%	35 x 61 km	Assuming a flight altitude of 700 kilometers and an Earth radius of 6,378 kilometers
7.3 GHz	1.8° ± 15%	35 x 61 km	
10.65 GHz	1.2° ± 15%	24 x 41 km	
18.7 GHz	0.65° ± 15%	13 x 22 km	
23.8 GHz	0.75° ± 15%	15 x 26 km	
36.5 GHz	0.35° ± 15%	7 x 12 km	
89.0 GHz A	0.15° ± 15%	3 x 5 km	
89.0 GHz B	0.15° ± 15%	3 x 5 km	

2.2.7.6 Overlap and underlap

The overlap in the flight direction is the ratio of the flight direction distance that consecutive scan-period footprints overlap. Conversely, underlapping is the condition when consecutive footprints do not overlap.

The overlap in the scanning direction is the ratio of the scanning direction distance that two footprints, covering consecutive integration periods in the scanning direction, overlap. Conversely, underlapping is the condition when these consecutive footprints do not overlap.

Table 2-14 provides the overlap ratios in both the flight direction and scanning

direction for each observation frequency assuming the nominal design conditions.

Table 2-14: Overlap ratios (under nominal design conditions)

Frequency Band	Overlap Ratio	
	Scanning Direction	Flight Direction
6.925 GHz	82.6%	86.6%
10.65 GHz	76.3%	80.3%
18.7 GHz	62.9%	63.0%
23.8 GHz	66.2%	67.8%
36.5 GHz	46.5%	29.5%
89GHz A/B	42.5%	22.6%

2.2.7.7 Frequency registration

Frequency registration accounts for the following error sources in the flight direction and the scanning direction.

- *Scanning direction*

- Antenna beam orientation error
- Imaging timing discrepancies
 (Errors in time correction calculations for each frequency to collect data from the same surface point)

- *Flight direction*

- Antenna beam orientation error
- Flight effects
 (Time differences for each frequency to collect data from the same surface point)

The initial antenna beam orientation error and the imaging timing discrepancies are error factors that emerge in the initial design, assembly, or production. The flight effects and antenna beam orientation fluctuations based on thermal distortions are error factors that emerge after launch.

Strictly speaking, the error factors in the flight direction actually affect both the flight direction and scanning direction, but the extent of their effect is maximized in the AMSR2's flight direction when making observations directly along the flight direction (when the scan passes through the X-Z plane). Consequently, the effects were evaluated under this condition. The effects in the scanning direction were

found to be substantially negligible.

The design accounted for all these error factors and has the center of the beam width for each frequency and each polarization pass along the same scan line, except for the 89 GHz band B channel, with an error in the flight direction within ± 0.16 degrees.

The sampling center error in the scanning direction is within ± 0.26 degrees measured from the sampling start position of the 89 GHz band A channel.

2.2.7.8 Pointing

The bore-sight misalignment of the AMSR2's sensor's antenna beams is estimated by aggregating the various tilt-angle error sources in the scanning direction and flight direction when the antenna beam is pointed along the sub-satellite track (in the center of the scanning arc), using the AMSR2's coordinate system with its origin at the center of the ADM installation plate. The error sources can be divided into a fixed error component that is a constant error independent of time, and a variable error component that is time-dependent. Because the fixed error component is constant, it can potentially be corrected by improving the angular error recognition accuracy, which includes assessments using observation data. The variable component, however, will be included in the observation data as an error.

2.3 A-Train

The Afternoon Constellation (A-Train) is a NASA-directed constellation of Earth observation satellites in a sun-synchronous orbit at an altitude of approximately 700 kilometers that crosses the equator each day at about 13:30.

Because the observation orbit of A-Train satellites is closely regulated, different satellites are able to observe the same surface point less than ten minutes apart.

The A-Train currently consists of four orbiting satellites — Aqua, Cloudsat, CALIPSO, and Aura. GCOM-W1 will join the A-Train with the aim of furthering scientific research using AMSR2 data.

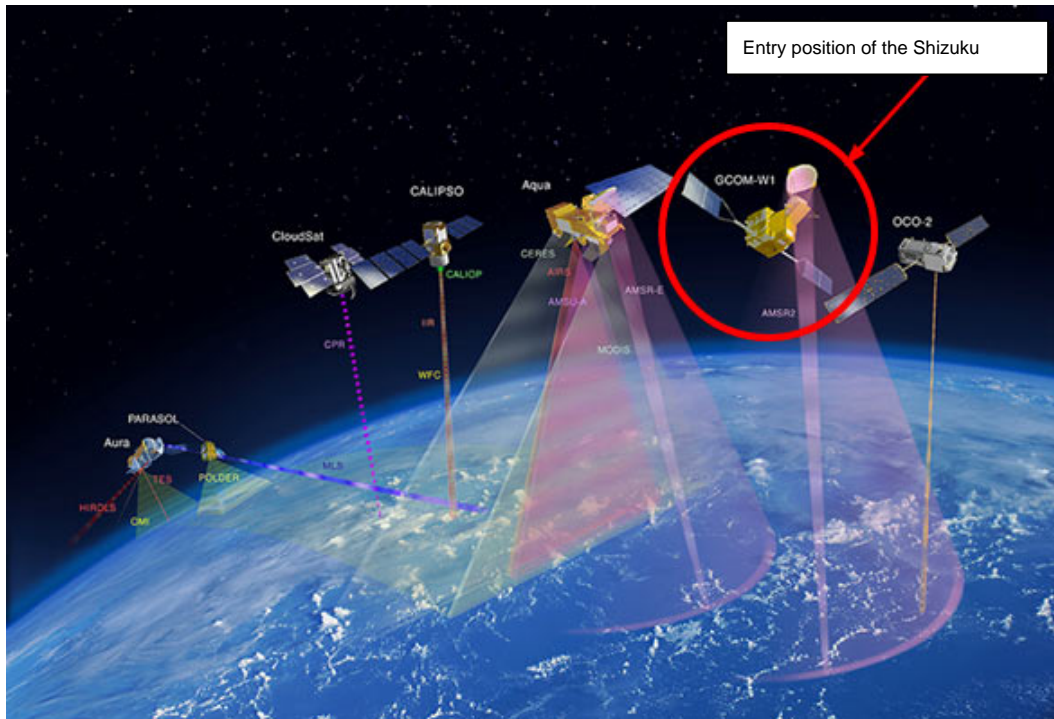

Figure 2-10: View of the A-Train

© NASA

Chapter 3 Overview of the GCOM-W1 Ground System

3.1 Overall System

The GCOM-W1 ground system comprises three systems: the satellite control system, the mission operation system, and the analysis and research system. In general, the satellite control system operates the satellite; the mission operation system is responsible for data processing; and the analysis and research system is used for algorithm development and calibration verifications. The mission operation system, which we will look at in detail here, is divided into three parts: the data processing system, which processed satellite observation data; the EORC information system, which stores and manages processes products and the satellite's operational data as well as transfers data within the system and to outside entities; and the data provision subsystem, which supplies data to general users.

The tracking network system makes use of the ground network system to receive telemetry data, send commands, and conduct ranging over the S band. Receiving and recording equipment at the domestic and international stations receives data over the X band, demodulates the observation data, and prepares APID sorted data (ASD).

The satellite control system both establishes the mission operation plan and the satellite operation plan and processes telemetry data / commands via the tracking network system and the Svalbard station.

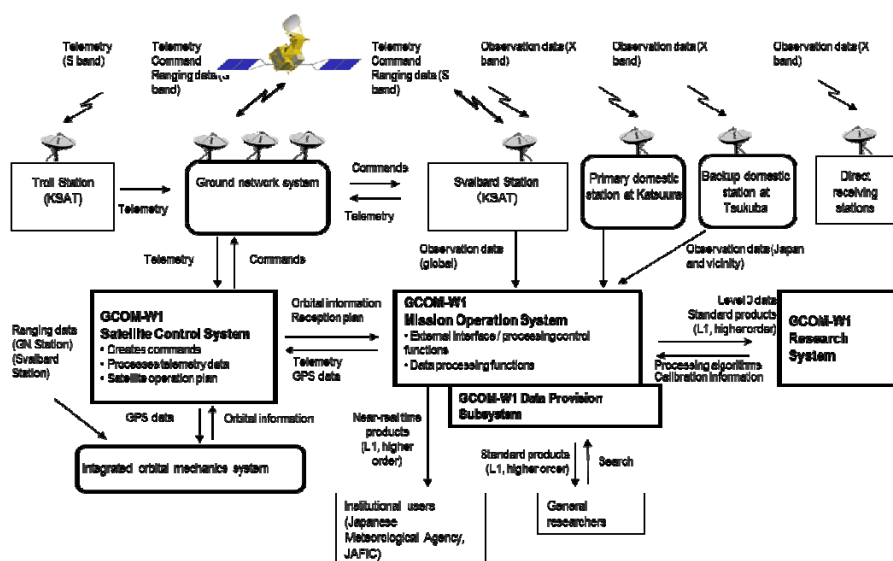

Figure 3-1: Overview of the GCOM-W1 ground system

The mission operation system processes observation data received over the X band by the receiving and recording equipment at the domestic and international stations. Data processing begins with the input of ASD and proceeds in three steps: Level 0, Level 1, and Higher Level Processing (Level 2 and Level 3). The system also takes care of data storage management and user services. And the system processes near-real time products and provides them to institutional users.

The analysis and research system takes Level 0 data and Level 1 products from the mission operation system for validating the algorithms and parameters used in processing and calibration.

3.2 GCOM-W1 Mission Operation System

The GCOM-W1 mission operation system takes as its input mission data received and demodulated at the X-band receiving stations and, after processing the AMSR2 data, stores and manages the data as an archive. The system also provides near-real time products to institutional users and acts as a service contact point for general users.

3.2.1 GCOM-W1 Data Processing System

The GCOM-W1 data processing system applies Level 0, Level 1, and Higher Level Processing to interfaced mission data (ASD) from the X-band receiving stations and provides the processing results to the EORC information system. The system also does near-real time processing for institutional users. This system contains the following subsystems.

3.2.1.1 Processing controller

This subsystem establishes the processing plan for GCOM-W1 mission data and manages the plan's status, controls processing functions according to the plan (such as calling external functions), and regulates the processing computer loads. And when a processing algorithm is updated, this subsystem reprocesses the data and governs, as above, the series of operations from processing plan establishment to data processing.

3.2.1.2 Individual processors

This subsystem executes (provides) processing functions (Level 0, Level 1, Higher-level, and near-real time processing) for GCOM-W1 / AMSR2 data based

on the processing controller's processing plan. The figure below illustrates the overall data processing scheme.

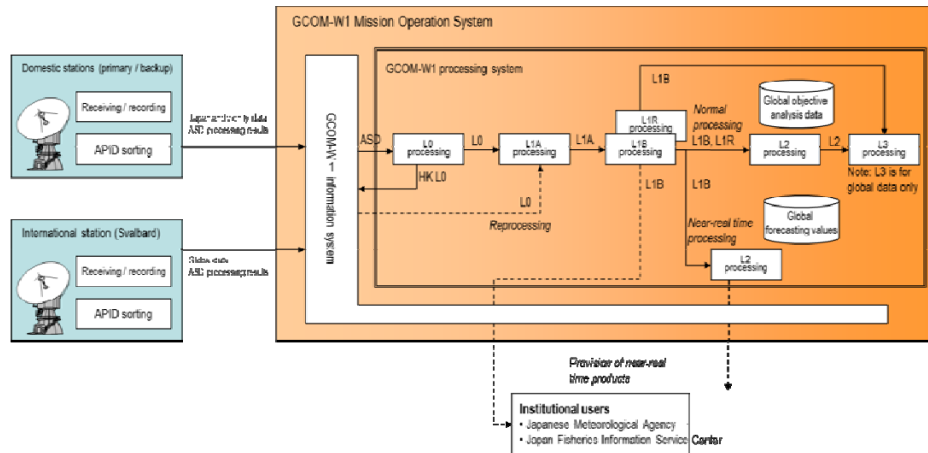

Figure 3-2: Overview of AMSR2 data processing

3.2.2 EORC Information System (for GCOM-W1)

The EORC information system acts as the primary interface between the mission operation system and the X-band receiving stations and other projects (equipment) at the Tsukuba Space Center. It also has the equipment for archiving mission data and supplying user services. This system contains the following subsystems.

3.2.2.1 Data transfer subsystem

This subsystem provides the data interface between the mission operation system and external mission operation systems that are associated with GCOM-W1 (such as the satellite control system, the tracking network system (including the domestic and international stations), and the analysis and research system).

Data transfers via this subsystem between external mission operation systems are permitted if the facility infrastructure allows for it.

3.2.2.2 Data management subsystem

This subsystem provides storage, management, and other functions for AMSR2 Level 0 data and Level 1 and Higher-level processed products created by the GEOSS data processing system (for GCOM-W1). It also stores and manages auxiliary data needed for data processing (such as orbital information and global objective analysis data).

Note that the most recent generation of Level 1 products is stored and managed in

accordance with the data storage policy for GCOM-W1 standard products. For higher-level processed products, the most recent generation and the previous generation are stored and managed.

3.2.2.3 Catalog management subsystem

This subsystem stores in a database catalog information on GCOM-W1 / AMSR2 standard products (Level 1 and higher-level processed products) and provides archived products in response to requests from users who receive products via the data provision subsystem described below.

3.2.2.4 Remote monitoring function

This function provides remote monitoring of the status of GCOM-W1 mission operation system's computers and equipment running the system's interfaces as well as the state of mission data reception, processing, and distribution. Remote monitoring is done from the satellite control system (in the operations room), which operates 24 hours a day.

3.2.3 GCOM-W1 Data Provision Subsystem

The GCOM-W1 data provision subsystem belongs to the GCOM-W1 mission operation system, maintains an interface with the EORC information system, and has the following functions to provide online data providing services to general researchers.

- Client information management function for general researchers (users)
- Search function for product archives
- Online product provision function
- Online tool provision function
- Status / history management function

Note that this subsystem provides the same search and provision functions for ADEOS-II / AMSR and Aqua / AMSR-E products, which belong to the same sensor family as AMSR2.



Figure 3-3: Home window of the GCOM-W1 data providing service

3.3 Receiving and Recording Equipment

The receiving and recording equipment (X-band receiving stations) used for GCOM-W1 operations are located at the Katsuura Station, Tsukuba Station, and KSAT (Svalbard Station). The domestic Katsuura Station and Tsukuba Station generally receive real-time visible signals and the Svalbard Station receives global observation data. The following sections give a brief explanation of each station.

3.3.1 Katsuura Station (primary domestic station)

Katsuura Station's receiving and recording equipment receives and records observation data collected at domestic antenna installations. The equipment provides ASD to the mission operation system. The main purpose of Katsuura Station's normal X-band operations is the reception and transfer of real-time observation data as well as real-time HK telemetry data. The received real-time HK telemetry data serve as a backup to the S-band real-time telemetry data.

Katsuura Station's equipment includes the following subsystems.

- RF subsystem (performs frequency conversions and demodulation)
- Baseband subsystem (performs CCSDS packet processing)
- Recording subsystem (that processes data as far as APID sorting)



Figure 3-4: View of Katsuura Station

3.3.2 Tsukuba Station (backup domestic station)

The KSAT conformance testing equipment located at the Tsukuba Space Center has been updated after conformance testing and has been outfitted to run the Tsukuba Station's X-band operations. Like the Katsuura Station, this equipment provides ASD to the mission operation system. The main purpose of the Tsukuba Station's X-band operations is the reception and transfer of real-time observation data as well as real-time HK telemetry data. The received real-time HK telemetry data serve as a backup to the S-band real-time telemetry data. Tsukuba Station operates as the backup domestic station when the primary Katsuura Station is offline because of contention with other satellites or for regular maintenance operations.



Figure 3-5: View of Tsukuba Station

Tsukuba Station's equipment includes the following subsystems.

- Antenna subsystem
- X-band modem subsystem
- Data acquisition subsystem
- S-band TT&C subsystem
- M&C subsystem

3.3.3 International Station

GCOM-W1 satellite operations make use of the Svalbard Station (located at 78° North latitude), operated by the Norwegian company, Kongsberg Satellite Services AS (KSAT).

3.3.3.1 KSAT / Svalbard Station

The KSAT / Svalbard Station is responsible for S-band TT&C operations (telemetry and commands) and X-band mission data transfer operations. During initial functional check-out operations, the station will confirm the ranging functions and performance and will conduct ranging operations if needed because of a satellite anomaly, etc. It also creates ASD from received X-band observation data and HK telemetry data, which it transfers to the mission operation system at the Tsukuba Space Center. The main purpose of the KSAT / Svalbard Station's normal X-band operations is the reception and transfer of observation data stored on the satellite's data recorder as well as stored HK telemetry data. The received real-time HK telemetry data serve as a backup to the S-band real-time telemetry data.



Figure 3-6: View of KSAT / Svalbard Station (taken from the KSAT website)

The KSAT / Svalbard Station maintains fully redundant receiving equipment. In

most reception failure cases, the equipment can be restored by the next pass even if the observation data transfer operation does not function temporarily. Therefore, the normal operation plan is to downlink two passes worth of data (the current pass and the previous pass) each downlink cycle.

The station monitors S-band real-time HK telemetry data in correspondence with the X-band reception pass. Commands are given for operations during anomalies, etc.

3.4 Overview of Ground System Operations

3.4.1 Data Reception

During normal operations, the KSAT / Svalbard Station is the downlink station for mission data, the Katsuura Station's purpose is to acquire observation data for Japan and vicinity, and the Tsukuba Station acts as a backup station. Downlinks to the KSAT / Svalbard Station, in principle, cover all visible passes. To cope with any short-term problems at the ground station or reception errors, each downlink cycle retrieves observation data from the last two passes. This station also operates the S band (TT&C).

Table 3-1 summarizes the satellite operations at each ground station.

Table 3-1: Ground station satellite operations

Station	TT&C Operations (S band)		Mission Data Transfer Operations (X band)			
	Command Ranging	Real-Time / Stored Telemetry	Stored Telemetry	Global Observation Data	Real-Time Telemetry	Real-Time Observation Data
Katsuura Station (X band)	—	—	Yes	Yes	Yes	Yes (Japan and vicinity)
Tsukuba Station (X band)	—	—	Yes	Yes	Yes	Yes (Japan and vicinity)
KSAT / Svalbard Station (S/X band)	Yes* ¹	Yes	Yes	Yes	Yes	Yes* ² (North Pole and vicinity)
KSAT / Troll Station (S band)	—	Yes	—	—	—	—
JAXA new GN Station (S band)	Yes	Yes	—	—	—	—

- *1. Svalbard Station undertakes ranging operations only when necessary.
- *2. As there are no plans to use real-time observation data from the North Pole and vicinity, this data will be received by the Svalbard Station but the data will not be distributed.

In addition to the above, real-time observation data will be distributed directly from the satellite by X-band transmissions to surface stations (direct domestic and international receiving stations) that request it. Transmissions to direct domestic and international receiving stations operate on the basis of an agreement between JAXA and the corresponding domestic or international institution.

Note that if the Svalbard Station cannot be used for a long period, transmission operations will be performed using backup international stations (Kiruna Station and Fairbanks Station).

The KSAT / Troll Station is used to receive S-band telemetry data (real-time and stored telemetry data). Reception of S-band telemetry data at the Troll Station is conducted within the range of downlinks established by the Troll Station's antenna (7.3 meter diameter).



Figure 3-7: View of KSAT / Troll Station (taken from the KSAT website)

3.4.2 Normal Processing

3.4.2.1 Processing by the mission operation system

Observation data received at the KSAT / Svalbard Station and the Katsuura Station are transferred as ASD to the mission operation system at the Tsukuba Space Center, where the data undergo Level 0, Level 1, and Higher Level Processing, as

defined in Table 3-2. The orbit and attitude information used in Level 1 processing is based on the use of the onboard GPS receiver's orbit and attitude values contained in the sensor packet's payload correction data (PCD). (When the GPS is not locked on, the GPS lock-off flag is raised and the attitude and orbit control system (AOCS) orbit propagation value is input in the PCD.) Note that in reprocessing, it is possible to also use the orbit generation values created with the unified flight dynamics system (uFDS).

Table 3-2: Definitions of mission data processing

Data Set	Details	Supplied to Operational Institutions	
		JMA	JAFIC
Raw data	Data set (CADU) after converting RF signals from the satellite (modulated waves are demodulated with a demodulator) to a bit-stream digital signal.		
APID sorted data (ASD)	Data set after sorting CADU by each VCID, synchronizing the data into CCSDS-compliant packets, and sorting them by APID.		
Level 0 data	Data set after sorting the previous data set based on the time and packet sequence count in the ASD and applying loss processing.		
Level 1A product	Data set after taking the Level 0 product as the input and applying the following processes: <ul style="list-style-type: none"> • Scene division • Calculation of radiometric correction data • Calculation of geometric data • Addition of packet loss data and quality data 		
Level 1B product (standard product)	Data set after taking the Level 1A product as the input and converting digital output values from the sensor to		

Data Set	Details	Supplied to Operational Institutions	
		JMA	JAFIC
	brightness temperatures.		
Near-real time Level 1B product (Japan and vicinity)	The Level 1B product uses real-time AMSR2 observation data for Japan and vicinity downlinked at the domestic stations and global AMSR2 observation data downlinked at the Svalbard Station to create near-real time data in downlinked units.	Yes*	
Level 1R product (standard product)	This product reorganizes the AMSR2 L1B product according to the resolution at each frequency.		
Level 2 product (standard product)	This product calculates various geophysical parameters related to water using the Level 1B or 1R products as inputs.		
Near-real time Level 2 product (Japan and vicinity)	This product provides near-real time Level 2 geophysical parameters created using the Japan and vicinity near-real time L1 product and global near-real time L1 product as inputs.	Yes*	Yes*
Level 3 product (standard product)	This product makes ground projections on the globe and in the North Pole and South Pole regions by taking the time and spatial averages of the Level 1B and Level 2 standard products. Daily and monthly statistical products are created for both ascending data sets and descending data sets.		Yes

*See Table 3-3 and Table 3-4 below for details on the products supplied in near-real time.

3.4.2.2 Delivering products to operational institutions

The Japan and vicinity and global AMSR2 brightness temperature product (L1B) and the geophysical parameter product generated through Higher Level Processing (L2) are supplied as given in Table 3-3 and Table 3-4 to the Japan Meteorological Agency (JMA) and the Japan Fisheries Information Service Center (JAFIC) within the delivery time requirements from observation to product delivery (near-real time processing requirements). Note that global observation data supplied in near-real time is delivered in the data units received at the KSAT / Svalbard Station.

The number of operational institutions provided with near-real-time products may expand in the future.

Table 3-3: Product delivery to operational institutions (for JMA)

Delivered Product		Coverage Region	Delivery Time Requirements
AMSR2 Level 1B Near-real-time product	Brightness temperature (TB)	Japan and vicinity	No less than 80% within 30 minutes of the observation time No less than 95% within 48 minutes of the observation time
		Global	No less than 70% within 2.5 hours of the observation time No less than 90% within 4.1 hours of the observation time
AMSR2 Level 2 Near-real-time product	Sea ice concentration (SIC)	Global	No less than 70% within 3.0 hours of the observation time No less than 90% within 5.0 hours of the observation time No less than 95% within 8.0 hours of the observation time

Delivered Product		Coverage Region	Delivery Time Requirements
	Snow depth (SND)	Global	No less than 90% within 5.0 hours of the observation time
	Soil moisture content (SMC)	Global	No less than 90% within 5.0 hours of the observation time
	Sea surface temperature (SST)	Global	No less than 70% within 3.0 hours of the observation time
			No less than 90% within 5.0 hours of the observation time No less than 95% within 8.0 hours of the observation time
	Sea surface wind speed (SSW)	Japan and vicinity	No less than 80% within 1.0 hours of the observation time
Global		No less than 70% within 3.0 hours of the observation time	

Table 3-4: Product delivery to operational institutions (for JAFIC)

Delivered Product		Covered Region	Delivery Time Requirements
AMSR2 Level 2 Near-real-time product	Sea surface temperature (SST)	Japan and vicinity	No less than 95% within 1.5 hours of the observation time
		Global	No less than 70% within 3.0 hours of the observation time No less than 90% within 5.0 hours of the observation time
AMSR2 Level 3 Standard product	Sea surface	Global	Delivered in the generated

Delivered Product		Covered Region	Delivery Time Requirements
	temperature (SST)		units Daily product: delivered once a day Monthly product: delivered once a month

3.4.2.3 User interface

Because AMSR2 makes continuous global observations regardless of the sunlight conditions, there is no input interface for the data user to make requests for observation operations; rather, observation data is provided from the GCOM-W1 data provision system.

3.4.2.4 Data archive

The mission operation system's data archive policy is given below.

- (1) Raw X-band data received at the international station are stored for seven days after reception on the international station's recording equipment and are converted to ASD and resent in response to resend commands from the mission operation system.
- (2) Raw X-band data received at the primary domestic station are stored for seven days after reception on the receiving station's recording equipment and are converted to ASD and resent in response to resend commands from the mission operation system. This policy holds for the backup domestic station as well.
- (3) The mission operation system treats Level 0 data, created from the observation data (ASD) transferred from receiving stations, as the master data and creates long-term archives of standard products, processing results (catalog information), etc. The master Level 0 data are stored at a backup facility in a location physically separate from the system installation center as well as at the mission operation system.

Chapter 4 AMSR2 Products

4.1 Product Definitions

4.1.1 Processing Level Definitions

Table 4-1 provides definitions of each AMSR2 product's processing level.

Table 4-1: AMSR2 product definitions

Processing Level	Description
Level 0	Data set with quality check flags appended.
Level 1A	A product that adds radiometric correction processing and geometric correction processing to the Level 0 data set, calculates antenna temperature conversion coefficients, antenna temperature count values, etc. and divides the data set by scene.
Level 1B	A product that converts antenna temperatures output in Level 1A to brightness temperatures using the conversion coefficients.
Level 1R	A product that resamples the Level 1B product using precalculated resampling coefficients to adjust data for lower frequency resolutions.
Level 2	A product that calculates geophysical parameters primarily related to water from the Level 1B product.
Level 3	A product that averages the Level 1B product and the Level 2 product spatially and over time with respect to predefined lattice grid points on the Earth surface and maps the averages on a global scale.

4.1.2 Scene Definitions

4.1.2.1 Level 1A, Level 1B, Level 1R, and Level 2 products

AMSR2 scenes are defined as a half orbit between the North Pole and the South Pole with respect to the observation position (Table 4-2). The AMSR2 observation position, as used in this definition, is not the position directly under the satellite, but the observation position on the Earth surface that is forward of the satellite along the sub-satellite track. Consequently, the scene is the area shifted approximately 2.5 minutes ahead of the position directly under the satellite (Figure 4-1). The

position where the observation is made forward of the satellite along the sub-satellite track is the scan center position and defines the observation point indicated in Table 4-3 (Figure 4-2).

The number of scans in one AMSR2 scene can be calculated using the interval between orbits, the total number of passes in one orbit, and the scanning interval. The number of scans in one scene is equivalent to one half orbit which takes about 49.4 minutes and consists of about 1,979 scans. The AMSR2 Level 1B product does not divide the observation data as AMSR/AMSR-E did. For this reason, the number of observation points does not change between the Level 1A product and the Level 1B product.

$$1978.7 = 86400 \text{ [seconds/day]} \times 16 \text{ [days/rec]} / 233 \text{ [orbits/rec]} / 1.5 \text{ [seconds/scan]} / 2 \text{ [scenes/orbit]} + 1 \text{ [the other pole]}$$

The number of scans in any one scene, however, fluctuates due to the effects of disturbances on the satellite's attitude, etc.

Table 4-2: AMSR2 scene definitions

Track Direction	Definition
Ascending scene	Half orbit scans from the southern most point to the northern most point (The southern most point is included at the start of the scene)
Descending scene	Half orbit scans from the northern most point to the southern most point (The northern most point is included at the start of the scene)

Table 4-3: Observation center positions

Processing Level / Frequency		No. of Observation Points	Start Position	Center Position
L1A and L1B	All but 89 GHz	243	1	122
	89 GHz	486	1	244

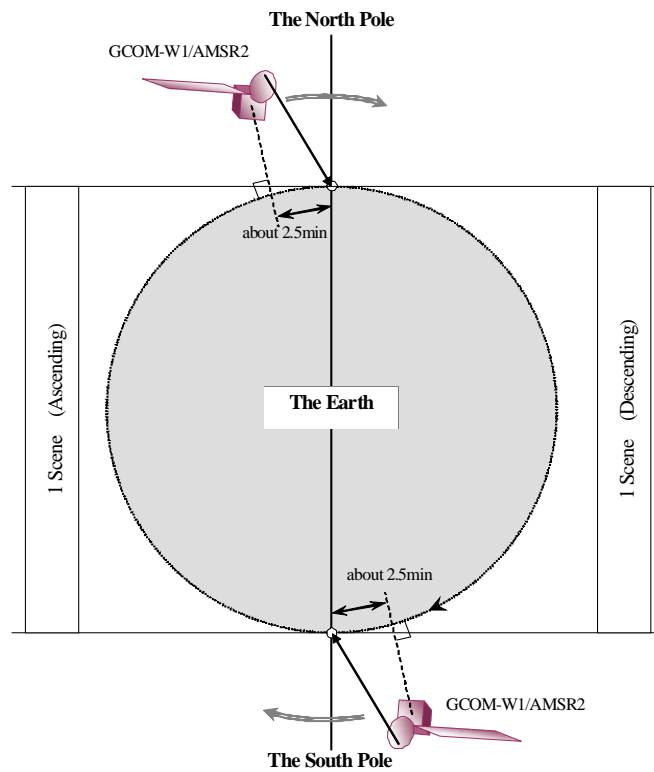

Figure 4-1: Relationship between the AMSR2 scene definitions and the position directly under the satellite

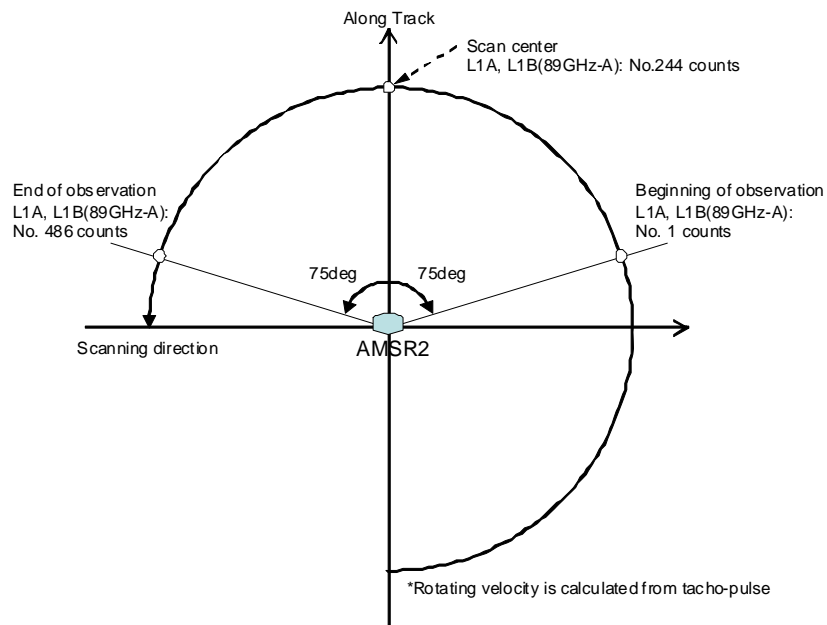
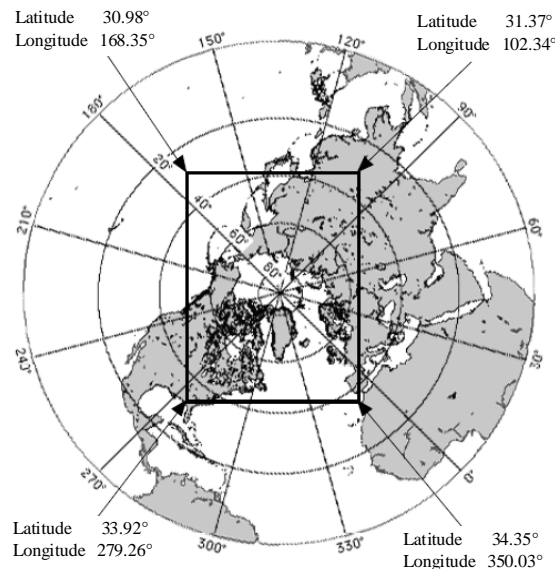

Figure 4-2: Relationship between the scan center observation point location and the number of data points

4.1.2.2 Level 3 product

The Level 3 product is a global data set, not scene-divided data.

- (1) There are two map projection methods: equi-rectangular (EQR) and polar stereo (PS).
- (2) The map lattice grid point interval is 0.25 degrees in the EQR map projection and 25 kilometers in the PS map projection.
- (3) PS map projections are defined in following figures.



*The latitude and longitude in this figure indicate the position at the edge of the pixel.

Figure 4-3: Definition of the Northern polar stereo projection [TB/SIC]

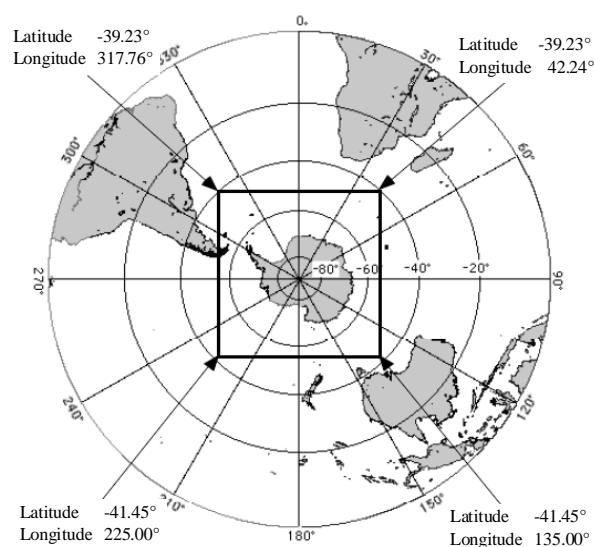

*The latitude and longitude in this figure indicate the position at the edge of the pixel.

Figure 4-4: Definition of the Southern polar stereo projection [TB/SIC]

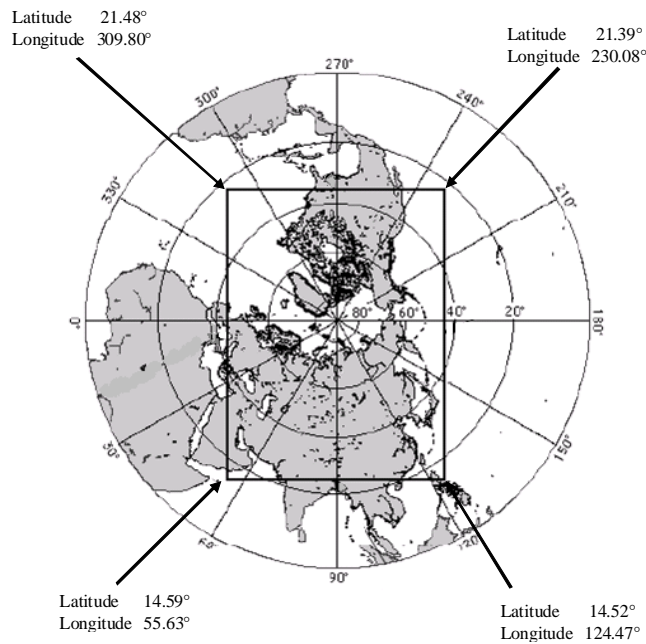

*The latitude and longitude in this figure indicate the position at the edge of the pixel.

Figure 4-5: Definition of the Northern polar stereo projection [TB/SND]

4.1.3 Product Definitions

4.1.3.1 Level 1 products

There are three types of AMSR2 Level 1 products, as shown in Table 4-4. One file is created for each scene in hierarchical data format (HDF).

Table 4-4: Data specifications for AMSR2 Level 1 products

Level	Processing Details	Observation Data Storage Format
1A	<ul style="list-style-type: none"> • Identifies observation data packets and deletes duplicate packets • Interpolates missing packets in the mission data with dummy packets • Converts observation data (12-bit) to a two-byte (16-bit) count value • Calculates the antenna temperature conversion coefficients necessary for Level 1B processing 	Count value

Level	Processing Details	Observation Data Storage Format
	<ul style="list-style-type: none"> • Calculates the latitude and longitude data, observation incidence angle and azimuth, and the solar elevation and azimuth for each observation data point • Appends packet loss data and quality data • Appends land or sea decision flags • Appends the overlap before and after the scene (10 scans each before and after the scene) • Appends quality information for each pixel (data on radio frequency interference (RFI)) 	
1B	<ul style="list-style-type: none"> • Converts Level 1A count values to antenna temperatures and then converts antenna temperatures to brightness temperatures (• AMSR2 does not divide the observation data as was done with AMSR / AMSR-E.) 	Brightness temperature after conversion
1R	<ul style="list-style-type: none"> • Creates the Level 1R product by resampling the Level 1B product's brightness temperatures using precalculated resampling coefficients to adjust for lower frequency resolutions • Calculates the average altitude over the observation region 	

4.1.3.2 Higher-level processing products

4.1.3.3 Level 2 products

- (1) Products that calculate geophysical parameters based on Level 1B data sets
- (2) Adds the same geometric data to Level 1B and stores quality data and metadata (orbit number and time for each scan in the TAI-93 (International Atomic Time) format, which is the number of seconds that have elapsed since 1993)

Table 4-5: List of AMSR2 Level 2 products

Product	Data Units	Coverage	Resolution
Total Precipitable Water	Scene (half orbit)	Global seas	15 km
Cloud liquid water		Global seas	15 km
Precipitation		Tropics and temperate zones	15 km
Sea surface temperature		Global seas	50 km
Sea surface wind speed		Global seas	15 km
Sea ice concentration		High latitude seas	15 km
Snow depth		Land areas	30 km
Soil moisture content		Land areas	50 km

4.1.3.4 Level 3 products

- (1) Level 3 products use Level 1B brightness temperature (TB) data set and Level 2 geophysical parameter data set and average them spatially and over time with respect to predefined lattice grid points on the Earth surface. There are two time averages: daily and monthly. The averaged data is mapped globally using both EQR and PR map projections.
- (2) All Level 3 products are global data sets, but there are two types: ascending global data sets and descending global data sets.

Table 4-6: List of AMSR2 Level 3 products

Product	Data Unit	Map Projection	Averages	Resolution
Brightness temperature	Global (Ascending / Descending)	EQR	Daily / Monthly	High resolution (0.1°) / Low resolution (0.25°)
		PS northern hemisphere	Daily / Monthly	High resolution (10 km) / Low resolution (25 km)
		PS southern hemisphere	Daily / Monthly	High resolution (10 km) / Low resolution (25 km)
Total Precipitable Water		EQR	Daily / Monthly	High resolution (0.1°) / Low resolution (0.25°)
Cloud liquid water		EQR	Daily / Monthly	High resolution (0.1°) / Low resolution (0.25°)
Precipitation		EQR	Daily / Monthly	High resolution (0.1°) / Low resolution (0.25°)
Sea surface temperature		EQR	Daily / Monthly	High resolution (0.1°) / Low resolution (0.25°)
Sea surface wind speed		EQR	Daily / Monthly	High resolution (0.1°) / Low resolution (0.25°)
Sea ice concentration		PS northern hemisphere	Daily / Monthly	High resolution (10 km) / Low resolution (25 km)
		PS southern hemisphere	Daily / Monthly	High resolution (10 km) / Low resolution (25 km)
Snow depth	EQR	Daily / Monthly	High resolution (0.1°) / Low resolution (0.25°)	
	PS northern hemisphere	Daily / Monthly	High resolution (10 km) / Low resolution (25 km)	
Soil moisture content	EQR	Daily / Monthly	High resolution (0.1°) / Low resolution (0.25°)	

4.2 Level 1 Processing Algorithms

4.2.1 Level 1A Process

The Level 1A process calculates radiometric data sets and geometric data sets, as given in Figure 4-6, using edited data output from the editing process as inputs. Note that the mission data loading and checking procedure consists of loading

AMSR2 mission data and checking the mission data's loss flags and HW flags. The time calculation procedure converts the satellite's GPS time to the TAI-93 time format and then calculates the observation start time while accounting for leap seconds.

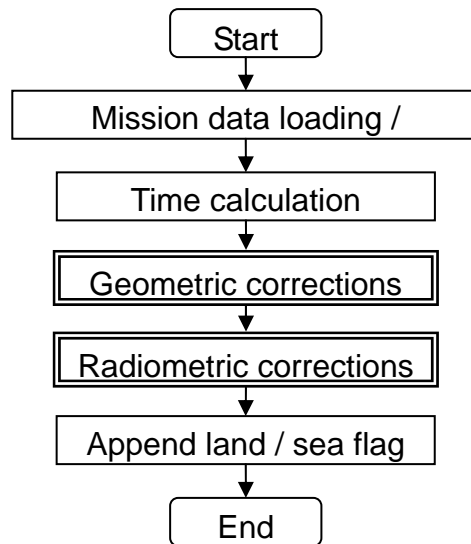

Figure 4-6: Level 1A product processing sequence

4.2.1.1 Geometric data set calculations

(1) Calculate the location of observation points

Figure 4-7 illustrates the processing sequence for calculating the latitude and longitude of observation points.

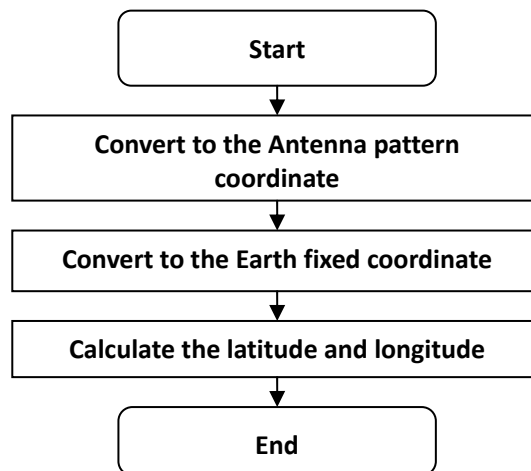

Figure 4-7: Processing sequence for calculating the observation points

To calculate the location on earth's surface, we should know the direction of AMSR2 antenna in a proper coordinate, the Earth Fixed coordinate. While the antenna direction is defined in the other coordinate, the Antenna Pattern coordinate, therefore we repeat the coordinate conversion from the Antenna Pattern coordinate to the Earth Fixed coordinate, via several interim coordinates. After we know the direction of AMSR2 antenna, we calculate the location, latitude/longitude of observation point.

This calculation is just for 89GHz-A channel, because it is the finest sampling. The location of the other low frequency channels are calculated using "Relative registration coefficient". Refer the format description document the detail of calculation.

89GHz-B channel observes the different position from the other channels, it cannot calculate using 89GHz-A channels position and Relative registration coefficient. Therefore we calculate the position of this channel in the same way of 89GHz-A channel and store them in the product independently.

In above calculation, we use WGS84 as the earth ellipsoid model.

The sketch of above calculation is shown in the below figure.

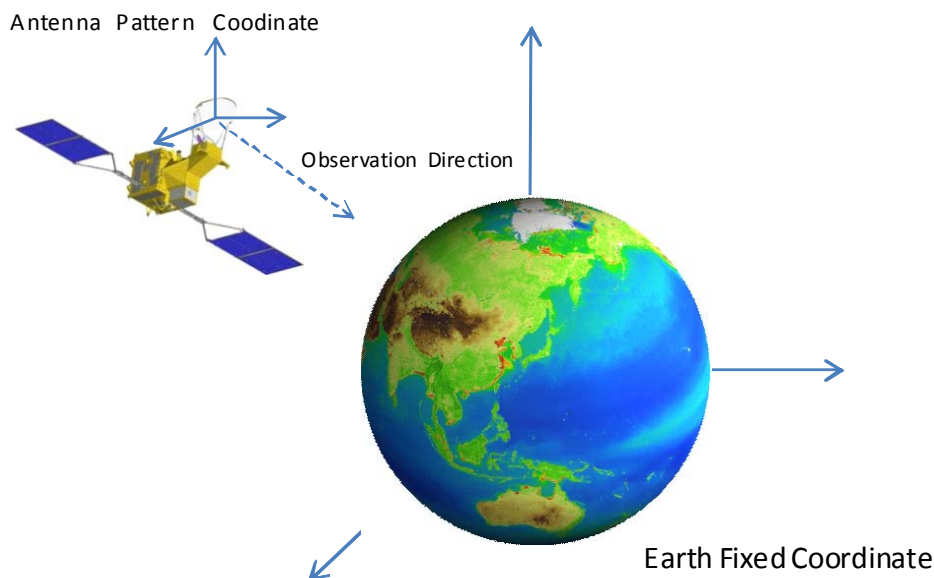

Figure 4-8: Sketch of calculating the longitude/latitude of observation point

- (2) Solar elevation and azimuth and incidence angle and azimuth at the Earth surface
The solar elevation and azimuth relative to the 89 GHz observation position is calculated using the latitude and longitude of the observation point calculated

above and the sun's position, and the incidence angle and azimuth at the Earth surface from the latitude and longitude.

(3) Setting the land / sea flag for all frequencies

Land / sea flags stored in a database are retrieved using the latitude and longitude of the observation point calculated above and the results are set in the data set.

4.2.1.2 Radiometric data set calculations

Figure 4-9 illustrates the processing sequence for calculating radiometric data.

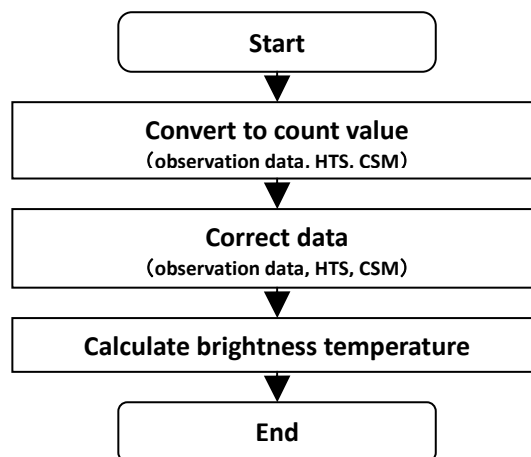

Figure 4-9: Processing sequence for calculating the antenna temperature conversion coefficients

(1) Identifying and averaging equal gain / offset points

Identify the range in which low-temperature and high-temperature correction data have been obtained at the same auto gain control (AGC) level (gain and offset) and average the calibration data obtained at equal gain levels. Data obtained at differing gains and offsets are not averaged.

(2) Correct the high-temperature noise source / cold sky mirror

The following corrections are made to the high-temperature noise source's temperature and the cold sky mirror's count value.

- a. Correct the high-temperature noise source's temperature (using a correction algorithm)
- b. Correct the cold sky mirror's temperature (eliminate the effects of the moon, Earth emissions, RFI, and sunlight)

(3) Calculating the antenna temperature conversion coefficients at all frequencies

The first-order calibration equation coefficients (A, B) are calculated in order to convert the observation count value (C_{obs}) to an antenna temperature (TA)

$$T_A = A \times C_{obs} + B$$

4.2.2 Level 1B Process

The Level 1B process corrects for scanning bias and receiver nonlinearity after antenna temperature conversion using the radiometric coefficients calculated in the Level 1A process and converts the results to brightness temperatures.

Figure 4-10 shows the Level 1B processing sequence.

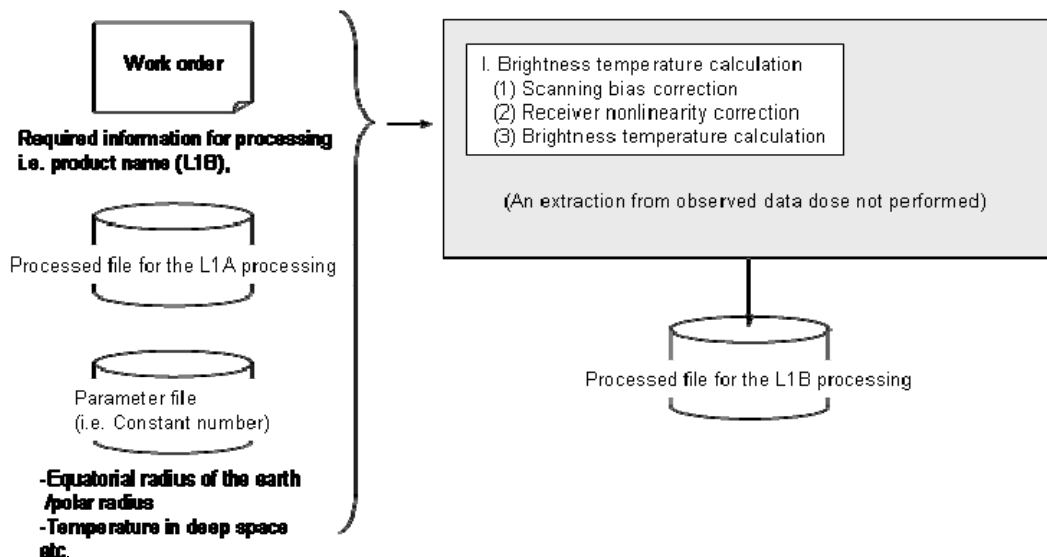

Figure 4-10: Processing sequence for the Level 1B product

4.2.2.1 Scanning bias correction

There is a possibility that observed antenna temperatures contain some bias at the observation points within a scan due to the effects of blocking, etc., by the calibration sources. For this reason, the Level 1B process includes functions to correct for this bias.

The bias tendency is thought to vary somewhat depending on the frequency and polarization, so separate coefficients are set for each frequency and polarization. Furthermore, separate coefficients are set because the coefficients change for each observation point location.

The conversion from the observation count value to the antenna temperature uses the equation shown in Section 4.2.1-II(3).

The scanning bias correction is made with the following equation on converted observation antenna temperatures. Table 4-7 gives the meaning of each coefficient in the equation.

$$T'_A = T_a \times Cg[i] + Co[i]$$

Table 4-7: Coefficients used in scanning bias corrections

Coefficient	Description	
T'_A	Antenna temperature after correcting for scanning bias	-
T_a	Antenna temperature	-
$Cg[i]$	Gain coefficient for scanning bias correction at each observation point (i: observation position)	Set for each observation point
$Co[i]$	Offset coefficient for scanning bias correction at each observation point (i: observation position)	Set for each observation point

4.2.2.2 Receiver nonlinearity correction

After correcting the antenna temperature for scanning bias, correction is made for receiver nonlinearity with the equation below.

$$T_A = A_L T'_A + B_L T'^2_A + C_L$$

T_A : Antenna temperature after correcting for nonlinearity

T'_A : Antenna temperature after correcting for scanning bias

A_L, B_L, C_L : Nonlinearity correction coefficients

Before launch the correction coefficients A_L, B_L, C_L are set to $A_L = 1, B_L = 0, C_L = 0$. After launch, the coefficients are determined through a calibration and verification process.

4.2.2.3 Brightness temperature calculation

To convert the antenna temperature after correcting for receiver nonlinearity described in Section 4.2.2.2 to a brightness temperature, the equation below is used to account for cross polarization and spillover correction. The coefficients are

set to precalculated values before launch, which are then readjusted through an assessment after launch.

$$T_{Bv} = A_{vv}T_{av} + A_{hv}T_{ah} + B_v$$

$$T_{Bh} = A_{vh}T_{av} + A_{hh}T_{ah} + B_h$$

Where, T_{Bv}, T_{Bh} : V polarized and H polarized observation brightness temperatures

T_{Av}, T_{Ah} : V polarized and H polarized observation antenna temperatures

A_{vv}, A_{hh} : V polarized and H polarized primary polarization contribution ratios

A_{hv}, A_{vh} : V polarized and H polarized cross polarization contribution ratios

B_v, B_h : V polarized and H polarized brightness temperature conversion biases

4.2.3 Level 1R Processes

In Level 1R, the process shown in Figure 4-11 is carried out using the Level 1B products as inputs.

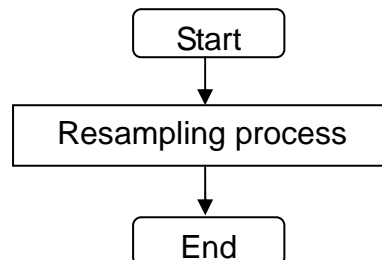

Figure 4-11: Processing sequence for Level 1R products

The Level 1R process resamples the Level 1B brightness temperature data in proportion to the low-frequency resolution. Resampling takes place by overlaying the original brightness temperature data with weighted parameters (resampling coefficients) calculated using the Backus-Gilbert Method. Figure 4-12 provides an overview of the resampling process.

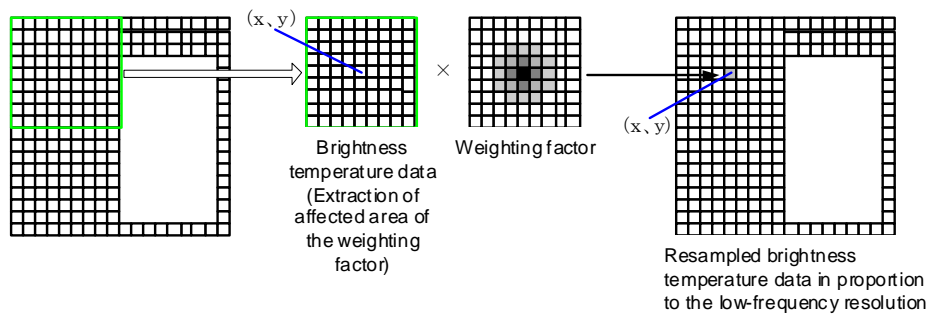

Figure 4-12: Overview of the Level 1R process

4.2.3.1 Frequencies selected for resampling

The following policy determines which frequencies to resample in the Level 1R process.

- (1) Resampling converts the brightness temperature at a higher resolution frequency to a brightness temperature at a lower resolution frequency.
- (2) There are several AMSR2 frequencies with the same or similar resolutions. 6 GHz and 7 GHz data sets have the same spatial resolution; therefore, a shared set of resampling data is created. 18 GHz and 23 GHz data sets have almost the same resolution, but 23 GHz resolution is slightly lower; therefore, one set of resampling data is created matching the 23 GHz resolution.
- (3) 89 GHz data sets consist of data from A and B channel receivers. The processing method of the two data sets is determined by the resampling coefficient rule (use only one data set, merge both data sets, etc.). Both data sets are input simultaneously into the process.
- (4) Resampling is done separately for H polarization and V polarization. For example, when resampling the H polarization of a given target frequency, the H-polarized L1B brightness temperature data at the other frequency are used, but the corresponding V-polarized brightness temperature data are not.

Table 4-8 summarizes these policies and lists the resampled frequencies.

Table 4-8: Frequencies selected for resampling

		Target Resolution Frequency				
		6/7 GHz	10 GHz	23 GHz	36 GHz	89 GHz
Observation frequency	6 GHz	☆	-	-	-	-
	7 GHz	☆	-	-	-	-
	10 GHz	○	☆	-	-	-
	18 GHz	○	○	○	-	-
	23 GHz	○	○	☆	-	-
	36 GHz	○	○	○	☆	-
	89 GHz	○	○	○	○	-

Notes:

○ and ☆ indicate frequencies that are processed and stored. ○ frequencies primarily undergo spatial resolution conversions, whereas ☆ frequencies primarily undergo processing for center latitude and longitude alignment; spatial resolution conversion is not the main purpose.

The process resamples the Level 1B brightness temperature data at frequencies marked by ○ and ☆ in Table 4-8 and outputs the resampled data as the Level 1R product. ○ frequencies primarily undergo spatial resolution conversions, whereas ☆ frequencies primarily undergo processing for center latitude and longitude alignment; spatial resolution conversion is not the main purpose. The center latitude and longitude is adjusted to the 89 GHz A channel receiver data. Note that the complete sets of original 89 GHz A and B channel brightness temperature data are also stored.

4.3 Higher Level Processing Algorithms

4.3.1 Level 2 Process

The Level 2 process calculates actual geophysical parameters using AMSR2 Level 1 data sets as inputs. Eight geophysical parameters are calculated: Total Precipitable Water, cloud liquid water, precipitation, sea surface wind speed, sea surface temperature, sea ice concentration, snow depth, and soil moisture content.

4.3.1.1 Total Precipitable Water

(1) Input data

The data inputs to the **Total Precipitable Water** calculation algorithm are as

follows:

- a. AMSR2 Level 1R products
 - 1) 18.7, 23.8, 36.5, 89.5 GHz brightness temperatures (horizontal and vertical polarizations)
 - 2) Latitude and longitude
 - 3) Incidence angle at the Earth surface
 - 4) Observation time
 - 5) Land / sea flags
- b. Sea surface temperatures (Japan Meteorological Agency's Merged satellite and in situ data Global Daily Sea Surface Temperatures in the global ocean (MGDSST) / JMA)
- c. 850 hPa temperatures (Japan Meteorological Agency's Global objective analysis data (GANAL) / JMA)
- d. Sea surface wind speeds (Japan Meteorological Agency's Global objective analysis data (GANAL) / JMA)
- e. Reference tables
 - 1) Reference table for calculating sea surface emissivity
 - 2) Reference table for calculating mean atmospheric temperature
 - 3) Reference table for Total Precipitable Water conversions

(2) Description of the algorithm

Water vapor and cloud liquid water emissivity in the atmosphere can be observed using microwave scanning radiometer measurements in the 19 GHz, 23 GHz, and 37 GHz bands. Radiance in the upper atmosphere is the integrated value of water vapor in the atmosphere and liquid water content in clouds. Correctly estimating emissivity from the sea surface is key to retrieving the Total Precipitable Water. Sea surface emissivity varies in accordance with the observed microwave frequency, the sea surface temperature, the sea surface wind speed, and the incidence angle at the Earth surface. This algorithm assumes a single homogenous isothermal atmosphere above the sea surface to simulate, with a microwave radiative transfer model, the radiation absorption by water vapor, oxygen, and ozone in the atmosphere and radiation absorption at the sea surface. Because the AMSR2 observation frequencies bands are not very sensitive to salt concentrations, the algorithm does not account for the effect of salt concentration variances on sea surface radiation. The algorithm does account for the effect of sea level undulations caused by wind and for emissivity variations caused by sea surface temperature differences. The dispersion process of water molecules in the atmosphere is

complex and takes considerable time to calculate. Therefore, Total Precipitable Water is not calculated in areas of precipitation.

Because each AMSR2 frequency band has a different sensitivity to water vapor and cloud liquid water, the Total Precipitable Water is calculated by combining multiple AMSR2 frequencies and polarizations.

a. Calculating the sea surface emissivity

The sea surface emissivity is found from a reference table using auxiliary sea surface temperature and sea surface wind speed data. The reference table is created by matching vertical atmospheric profile data obtained from sondes, AMSR2 observed brightness temperatures, and auxiliary sea surface temperature and sea surface wind speed data.

b. Calculating the mean atmospheric radiation temperature and the atmospheric transmittance multiple

An initial value is input for the atmospheric transmittance (T_r). The mean atmospheric radiation temperature (T_a) is found from the second reference table. The reference table is created from the atmospheric transmittance (T_r) and the atmospheric temperature at 850 hPa. The reference table is created in advance using sonde vertical atmospheric profile data (temperatures and humidity) and a microwave radiative transfer model.

The parameter α is calculated for each observation frequency and polarization using Equation 2.

The atmospheric transmittance (T_r) is calculated from the AMSR2 brightness temperature for each of the two polarizations using Equation 3.

The atmospheric transmittance (T_r) at each of the observation frequencies is estimated by taking the geometric mean of the transmittance found for both polarizations. Through iterations of this calculation, a convergence value for the atmospheric transmittance (T_r) is found.

$$T_b = \alpha \left\{ 1 - (1 - \varepsilon_s) T_r^2 \right\} \quad [1]$$

$$\alpha = \left\{ T_a + \frac{(T_s - T_a) T_r \varepsilon_s}{1 - (1 - \varepsilon_s) T_r^2} \right\} \quad [2]$$

$$T_r^2 = \frac{1 - T_b / \alpha}{1 - \varepsilon_s} \quad [3]$$

c. Calculating the precipitable water index and the cloud liquid water index

First the cloud liquid water index (CWI) is calculated from the atmospheric transmittance multiple for the 18.7 GHz and 36.5 GHz bands. Then the precipitable water index (PWI) is calculated from the constant γ and the coefficient β , which is obtained from the reference table that defines the correlation between the CWI, the atmospheric transmittance multiple for the 18.7 GHz and 36.5 GHz bands, and the sea surface temperature. Note that this reference table has been prepared for maximum correlation between the PWI and the Total Precipitable Water calculated with radiosonde data.

$$PWI = \beta \ln(T_{r19HV}^2) - \ln(T_{r22V}^2) + \gamma CWI \quad [4]$$

$$CWI = \ln(T_{r19HV}^2) - \ln(T_{r37HV}^2) \quad [5]$$

d. Calculating the Total Precipitable Water

The Total Precipitable Water is calculated by converting the PWI to a PWA (kg/m^2) using a reference table adjusted so that the PWI calculated from AMSR2 observation data matches the PWA calculated from radiosonde observation data. During the conversion, a parameter is used to eliminate the 36.5 GHz band's wind speed dependency (S36 defined in the AMSR2 wind-speed algorithm).

4.3.1.2 Cloud liquid water

(1) Input data

The data inputs to the cloud liquid water calculation algorithm are as follows:

a. AMSR2 Level 1R products

- 1) 18.7, 23.8, 36.5, 89.5 GHz brightness temperatures (horizontal and vertical polarizations)
- 2) Latitude and longitude
- 3) Incidence angle at the Earth surface
- 4) Observation time
- 5) Land / sea flags

b. Sea surface temperatures (Japan Meteorological Agency's Merged satellite and in situ data Global Daily Sea Surface Temperatures in the global ocean (MGDSST) / JMA)

c. 850 hPa temperatures (Japan Meteorological Agency's Global objective analysis data (GANAL) / JMA)

d. Sea surface wind speeds (Japan Meteorological Agency's Global objective

analysis data (GANAL) / JMA)

e. Reference tables

- 1) Reference table for calculating sea surface emissivity
- 2) Reference table for calculating mean atmospheric temperature
- 3) Reference table for cloud liquid water conversions

(2) Description of the algorithm

Water vapor and cloud liquid water emissivity in the atmosphere can be observed using microwave scanning radiometer measurements in the 19 GHz, 23 GHz, and 37 GHz bands. Radiance in the upper atmosphere is the integrated value of water vapor in the atmosphere and liquid water content in clouds. Correctly estimating emissivity from the sea surface is key to retrieving the Total Precipitable Water. Sea surface emissivity varies in accordance with the observed microwave frequency, the sea surface temperature, the sea surface wind speed, and the incidence angle at the Earth surface. This algorithm assumes a single homogenous isothermal atmosphere above the sea surface to simulate, with a microwave radiative transfer model, the radiation absorption by water vapor, oxygen, and ozone in the atmosphere and radiation absorption at the sea surface. Because the AMSR2 observation frequencies bands are not very sensitive to salt concentrations, the algorithm does not account for the effect of salt concentration variances on sea surface radiation. The algorithm does account for the effect of sea level undulations caused by wind and for emissivity variations caused by sea surface temperature differences. The dispersion process of water molecules in the atmosphere is complex and takes considerable time to calculate. Therefore, cloud liquid water is not calculated in areas of precipitation.

Because each AMSR2 frequency band has a different sensitivity to water vapor and cloud liquid water, the cloud liquid water is calculated by combining multiple AMSR2 frequencies and polarizations.

a. Calculating the sea surface emissivity

The sea surface emissivity is found from a reference table using auxiliary sea surface temperature and sea surface wind speed data. The reference table is created by matching vertical atmospheric profile data obtained from sondes, AMSR2 observed brightness temperatures, and auxiliary sea surface temperature and sea surface wind speed data.

b. Calculating the mean atmospheric radiation temperature and the atmospheric

transmittance multiple

An initial value is input for the atmospheric transmittance (T_r). The mean atmospheric radiation temperature (T_a) is found from the second reference table. The reference table is created from the atmospheric transmittance (T_r) and the atmospheric temperature at 850 hPa. The reference table is created in advance using sonde vertical atmospheric profile data (temperatures and humidity) and a microwave radiative transfer model.

The parameter α is calculated for each observation frequency and polarization using Equation 2.

The atmospheric transmittance (T_r) is calculated from the AMSR2 brightness temperature for each of the two polarizations using Equation 3.

The atmospheric transmittance (T_r) at each of the observation frequencies is estimated by taking the geometric mean of the transmittance found for both polarizations. Through iterations of this calculation, a convergence value for the atmospheric transmittance (T_r) is found.

$$T_b = \alpha \left\{ 1 - (1 - \varepsilon_s) T_r^2 \right\} \quad [1]$$

$$\alpha = \left\{ T_a + \frac{(T_s - T_a) T_r \varepsilon_s}{1 - (1 - \varepsilon_s) T_r^2} \right\} \quad [2]$$

$$T_r^2 = \frac{1 - T_b / \alpha}{1 - \varepsilon_s} \quad [3]$$

c. Calculating the cloud liquid water index

The cloud liquid water index (CWI) is calculated from the atmospheric transmittance multiple for the 18.7 GHz and 36.5 GHz bands.

$$CWI = \ln(T_{r19HV}^2) - \ln(T_{r37HV}^2) \quad [4]$$

d. Calculating the cloud liquid water

Because the calculated CWI is affected by water vapor, the cloud liquid water (CLW) is calculated after applying water vapor correction using the AMSR2-calculated PWA, in consideration of the dependency on different water vapor levels.

4.3.1.3 Precipitation

(1) Input data

The data inputs to the precipitation calculation algorithm are as follows:

- a. AMSR2 Level 1B products
 - 1) 10.65, 18.7, 36.5, 89.0 GHz brightness temperatures (horizontal and vertical polarizations) and 23.8 GHz bright temperatures (vertical polarization)
 - 2) Latitude and longitude
 - 3) Incidence angle at the Earth surface
 - 4) Land / sea flags
- b. Air temperatures (Japan Meteorological Agency's Global objective analysis data (GANAL) / JMA)
- c. Surface temperatures (Japan Meteorological Agency's Global objective analysis data (GANAL) / JMA)
- d. 0° altitude (Japan Meteorological Agency's Global objective analysis data (GANAL) / JMA)
- e. Sea surface temperatures (Japan Meteorological Agency's Merged satellite and in situ data Global Daily Sea Surface Temperatures in the global ocean (MGDSST) / JMA)

(2) Description of the algorithm

The special characteristic of this algorithm is that it finds an optimal value for the precipitation that gives a calculated brightness temperature value that minimizes the difference with the observed multi-wavelength brightness temperature value. The algorithm consists of a forward calculation part that creates a look-up table (LUT) and a retrieval part that estimates the precipitation from the LUT and the observed brightness temperature. The algorithm estimates precipitation in sea regions, land regions, and coastal regions, excluding regions of sea ice or cold temperatures and high latitude regions. Separate algorithms are applied for sea regions, land regions, and coastal regions. Generally speaking, the forecast accuracy for sea regions is better than that for land regions or coastal regions. Regions of sea ice or cold temperatures and high latitude regions are determined within the algorithm based on position information, brightness temperature information, and other data.

a. Forward calculation

A radiation transfer equation is used to form the relationship between precipitation intensities and rising or falling radiation brightness temperatures in the forward

calculation part of the algorithm. In other words, a precipitation physics model with a given precipitation intensity (classification of convection precipitation and stratiform precipitation, precipitation type, precipitation profile, raindrop size distribution, altitude of the melting layer, etc.) is incorporated in the radiation transfer equation and a calculated value of the radiation brightness temperature observed by the satellite is found. Specifically, then, the air temperature, altitude, water vapor, surface wind speed (using Japan Meteorological Agency's Global objective analysis data), and sea surface temperature are used as input values and the radiation brightness temperatures for all observed frequencies are calculated with respect to various precipitation intensities based on the assumed precipitation physics model. A table is then made of the relationship between precipitation intensities and radiation brightness temperatures.

Creating the LUT first involves making calculations for uniform precipitation, estimating the non-uniformity of the rain from the initial precipitation intensity estimate, and then revising the non-uniformity. This correction is necessary when precipitation in the observed field of view is non-uniform — for example, the radiation brightness temperature varies even through the average precipitation intensity in the observed field of view is the same.

Another distinction of this algorithm is that it determines the 0° Celsius altitude, which demarks liquid precipitation from solid precipitation, based on Japan Meteorological Agency's Global objective analysis data rather than estimating the melting layer altitude from unreliable observation data.

Note that the LUT is calculated for each 5° x 5° (latitude x longitude) rectangular area.

b. Retrieval

In the retrieval part of the algorithm, the precipitation intensity is estimated from observed brightness temperatures based on the LUT. The retrieval part's sequence is as follows: initial precipitation intensity estimate, determination of rainfall over land, sea, or coastlines, non-uniformity correction, dispersion algorithm, and radiation algorithm (over seas only).

4.3.1.4 Sea surface wind speed

(1) Input data

The data inputs to the sea surface wind speed calculation algorithm are as follows:

a. AMSR2 Level 1B products

- 1) 10.65 and 36.5 GHz brightness temperatures (horizontal and vertical

polarizations)

- 2) 6.925 GHz brightness temperatures (horizontal polarization)
- b. Sea surface temperatures (Japan Meteorological Agency's Merged satellite and in situ data Global Daily Sea Surface Temperatures in the global ocean (MGDSST) / JMA)
- c. Air temperatures (Japan Meteorological Agency's Global objective analysis data (GANAL) / JMA)

(2) Description of the algorithm

Sea surface wind speeds are calculated from vertical-polarized and horizontal-polarized 36.5 GHz brightness temperatures. Brightness temperatures at higher frequencies are susceptible to atmospheric effects. Consequently, atmospheric effects are observed using the lower 6 GHz frequency. The vertical-polarized 6 GHz signal increases with the effect of wind speed; it is zero in areas of light winds under 6 m/s but becomes larger as winds increase. The horizontal-polarized 6 GHz signal, however, increases even in areas of light winds and its degree of increase is greater than that for the vertical-polarized 6 GHz signal at all wind speeds. Another difficulty is the large anisotropy varies according to the angle between the AMSR2 antenna's orientation direction and the sea surface wind direction. In the 6 GHz band, this anisotropy in vertical-polarized signals reaches its maximum value with crosswinds and reaches its minimum with upwinds and downwinds. This phenomenon holds for the 36 GHz band as well.

Consequently, the algorithm uses 36 GHz data, calculates S36 defined in Equation 1, and, after removing the anisotropy, converts the results to a wind speed.

a. Calculating S36

$$S36=(36H-(ax(36V-208)-b))/f + t \quad [1]$$

$$f=1-(36V-200)\times 0.01 \quad [2]$$

The coefficients a and b are dependent on the sea temperature. The coefficients for sea temperatures between 0° and 30° Celsius in 5° Celsius intervals are found by comparing S36 and SeaWinds' wind speeds.

Table 4-9 lists the coefficient values.

Table 4-9: Sea temperature dependency of coefficients a and b

SST	a	b
0°C	2.23	132.0
5	2.20	132.2
10	2.14	131.5
15	2.07	130.7
20	2.06	128.8
25	2.03	127.4
30	2.06	124.2

b. Correcting S36's anisotropy

Anisotropy that varies according to the relative direction of the wind remains in the calculated S36 value. The anisotropy can be estimated by combining S36 and 6H* (the remaining value after removing atmospheric effects and sea surface temperature effects). Figure 4-13 shows the values of S36 and 6H* for upwinds, crosswinds, and downwinds at wind speeds between 1 m/s and 19 m/s in 2 m/s intervals. S36 reaches its maximum value with downwinds and its minimum value with upwinds. 6H* reaches its maximum value with crosswinds and its minimum value with downwinds and upwinds. Correcting for anisotropy means adjusting the downwind and upwind S36 values to the crosswind S36 values that match the fitting curve shown in Figure 4-13. The slopes from upwinds to crosswinds and from downwinds to crosswinds are different.

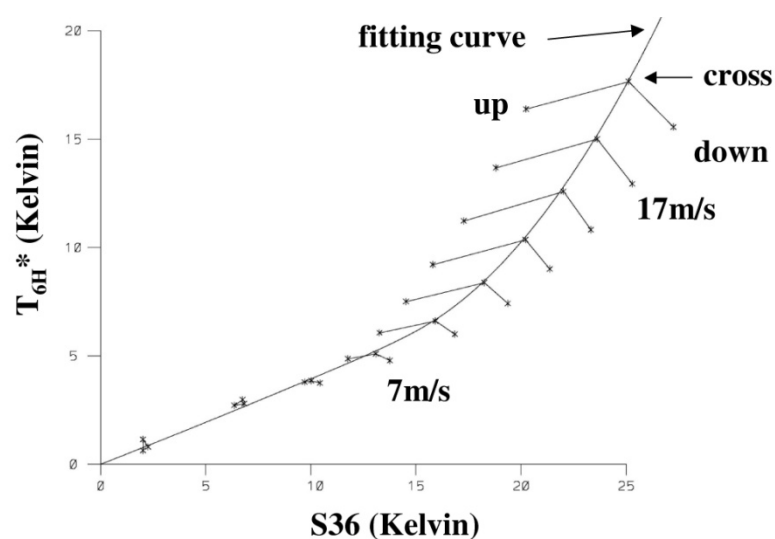

Figure 4-13: Method of correcting S36 for anisotropy

c. Converting from S36 to wind speeds

The algorithm finally translates the S36 value after removing the anisotropy (the crosswind-equivalent S36 value) to a wind speed using a conversion curve. The conversion curve was created referring to 3 x 10⁸ SeaWinds wind speeds over a seven-month span. Because the S36 value occasionally becomes negative, a conversion method for negative values has also been created. The causes of negative S36 values are errors in the sea surface temperature calculated from averaged sea surface temperatures and AMSR brightness temperature noise. The error still remaining in S36 after correction is the source of wind speed errors. An error of 1 Kelvin in S36 represents an error of 1 m/s in a wind speed between 15 m/s and 20 m/s.

4.3.1.5 Sea surface temperature

(1) Input data

The data inputs to the sea surface temperature (SST) calculation algorithm are as follows:

a. AMSR2 Level 1B products

- 1) 6.925 and 10.65 GHz brightness temperatures (horizontal and vertical polarizations)
- 2) 23.8 and 36.5 GHz brightness temperatures (vertical polarization)

b. Sea surface temperatures (Japan Meteorological Agency's Merged satellite and in situ data Global Daily Sea Surface Temperatures in the global ocean (MGDSST) / JMA)

c. Air temperatures (Japan Meteorological Agency's Global objective analysis data (GANAL) / JMA)

(2) Description of the algorithm

The algorithm calculates SST using 6 GHz vertical-polarized observation data. Unfortunately, 6 GHz vertical-polarized observation data contain signals from many other parameters in addition to SST. These include (a) atmospheric effects, (b) wind effects, (c) salt content effects, (d) contamination due to land, (e) contamination due to sea ice, and (f) sun glitter effects. Of the first three influences, the effects of salt content in the sea are very small. The effect of salt content can be corrected for using monthly average sea-salt climate values. Contamination components from (d) to (f) are much larger, so the algorithm attempts to remove these areas as much as possible. Losses caused by land effects extend as far as 100 kilometers from coastlines. And losses from sun glitter occur when the angle

between the AMSR2 incidence angle and the sun's incidence angle is around 25 degrees or less. For sea ice, the algorithm eliminates pixels identified by AMSR2 as sea ice. The effects from (a) to (c) and the contamination components from (d) to (f) are inherent to all microwave scanning radiometers. But the algorithm must also correct for additional errors specific to AMSR2. These are (g) incidence angle dependencies, (h) scan bias error, and (i) RFI.

The AMSR2 algorithm uses MGDSST supplied by JMA as the initial value when calculating SST.

The following sections describe three main AMSR2 sea surface temperature calculation processes: atmosphere correction, sea surface wind speed correction, and conversion to sea surface temperatures.

a. Atmosphere correction

The algorithm uses vertical-polarized observation data in the 23.8 and 36.5 GHz bands to correct for atmospheric effects in 6.925 and 10.65 GHz band observation data. However, because 23.8 and 36.5 GHz brightness temperatures vary according to the sea surface temperature, a table is made providing correction values for sea surface temperatures over the range 0° to 35° Celsius in 5° Celsius intervals.

The algorithm must remove observation data affected by rain since the SST accuracy is degraded in areas of rainfall. This process involves counting observation data in a specified threshold range within the 6.925 and 10.65 GHz band's field of view. In locations where the observation data values outside of the threshold range are more numerous than valid data values, SST is not calculated.

b. Sea surface wind speed correction

Observed vertical-polarized brightness temperatures are constant at sea surface wind speeds of less than 7 to 8 m/s, but horizontal-polarized brightness temperatures increase proportionally to low speed winds. When sea surface wind speeds exceed 7 to 8 m/s, both vertical-polarized and horizontal-polarized brightness temperatures rise. Based on this relationship, sea surface wind speeds are corrected independently for each frequency using 6.925 and 10.65 GHz band vertical-polarized and horizontal-polarized brightness temperatures.

c. Conversion to sea surface temperatures

6V is the value after the all the corrections above are made. 6V is calculated using the Klein-Swift (1977) complex dielectric constant of the sea surface temperature

after removing coastal regions, sea ice and adjacent regions, and regions of sun glitter. 6V is converted to a sea surface temperature using a curve that associates 6V and sea surface temperature. Because there are slight errors in this value, the calculation is made after adding correction to the curve to minimize differences with buoy water temperatures.

4.3.1.6 Snow depth

(1) Input data

The data inputs to the snow depth calculation algorithm are as follows:

- a. AMSR2 Level 1 products
 - 1) 89.5 GHz brightness temperatures (vertical polarization)
 - 2) 10.65, 18.7, 23.8, 36.5 GHz brightness temperatures (horizontal and vertical polarizations)
 - 3) Latitude and longitude
 - 4) Incidence angle at the Earth surface
- b. Auxiliary data
 - 1) Land / sea / coast / ice masks
 - 2) Snow climate data
 - 3) Forest coverage ratios
 - 4) Forest densities

(2) Description of the algorithm

The wavelength differences in the strength of snow emissions are dependent on several physical variables, the temperature of the snow, the snow crystal size, the volume of the snow, the state of the underlying surface, and vegetation.

On a satellite scale, the ratio of moisture content in the instantaneous field of view is important.

Dry snow more than five centimeters deep or a snow water equivalent of over 10 millimeters shows up in the microwave scanning radiometer's readings as isotropic dispersion caused by the snow crystals.

Snow emissions are almost impossible to detect at frequencies below about 20 GHz, but the emissions are large at frequencies over 20 GHz. The dispersion property of accumulated snow is the basic principle used to find snow depth.

a. Calculating the surface temperature (T)

The algorithm calculates the surface temperature in order to determine the possibility of accumulated snow in a target pixel. The surface temperature (T)

calculation uses 18.7, 23.8, and 89.5 GHz vertical-polarized brightness temperatures and 36.5 GHz horizontal-polarized brightness temperatures.

$$T = 58.08 - 0.39Tb_{18V} + 1.21Tb_{22V} - 0.37Tb_{36H} + 0.36Tb_{89V} \quad [1]$$

b. Calculating the snow depth

The algorithm determines if the snow depth is deep (including intermediate levels) or shallow.

There are two criteria when the snow depth found to be deep (including intermediate levels).

The first criterion is that difference between the non-dispersion channel and the dispersion channel is larger than zero. When the difference between the non-dispersion channel and the dispersion channel is positive, it indicates the presence of a dispersion media. AMSR2 uses 10 GHz as the non-dispersion channel and 36 GHz as the dispersion channel. When the algorithm sees a positive difference between the horizontal and vertical polarizations at 10 GHz and 36 GHz, it determines that accumulated snow is present.

The second criterion differentiates between dispersion by rainfall and dispersion by snow.

Although the physical property used to estimate the presence and amount of snow is dispersion, dispersion is caused by rainfall as well as by dry snow. Therefore, a threshold is set to differentiate between the two types of dispersion. Rainfall shows up as a higher value in 36 GHz band brightness temperatures than snow. When the 36 GHz vertical-polarized brightness temperature is less than the threshold of 255 Kelvin and the 36 GHz horizontal-polarized brightness temperature is less than 245 Kelvin, the algorithm determines that accumulated snow is present and not rainfall. When both of the conditions above are satisfied, the snow depth (SD), the snow depth in forested regions (SD_f), and the snow depth in open regions (SD_o) are calculated using forest coverage ratios (ff) and forest density (fd).

$$SD = ff(SD_f) + (1 - ff) \times (SD_o)[cm] \quad [2]$$

$$SD_f = 1/\log_{10}(Tb_{36V} - Tb_{36H}) \times (Tb_{18V} - Tb_{36V}) / (1 - fd \times 0.6)[cm] \quad [3]$$

$$SD_o = [1/\log_{10}(Tb_{36V} - Tb_{36H}) \times (Tb_{10V} - Tb_{36V}) + [1/\log_{10}(Tb_{18V} - Tb_{18H}) \times (Tb_{10V} - Tb_{18V})][cm] \quad [4]$$

When the snow depth is shallow, there is no response in the 36 GHz band.

Therefore, the surface temperature (T) is found with the 23 GHz vertical and horizontal polarized brightness temperatures (Tb23V and Tb23H) and the 89 GHz vertical and horizontal polarized brightness temperatures (Tb89V and Tb89H). Shallow accumulated snow possibly exists when the surface temperature is less than 267 Kelvin. The algorithm uses Equation 5 to confirm the presence of shallow accumulated snow.

$$Tb_{23V} > Tb_{89V} \ \& \ Tb_{89V} < 255K \ \& \ Tb_{23H} > Tb_{89H} \ \& \ Tb_{89H} < 255K \ \& \ T < 267K$$

[5]

In locations where Equation 5 is satisfied, shallow accumulated snow exists. Atmospheric effects are minimized by confirming that the 89 GHz brightness temperature is under 255 Kelvin and that the surface temperature is under 267 Kelvin to ensure the low brightness temperatures are the result of accumulated snow emissions.

When the algorithm determines with Equation 5 that snow depth is shallow, it calculates the snow depth (SD) with Equation 6.

$$SD = 5.0[cm]$$

[6]

4.3.1.7 Sea ice concentration

(1) Input data

The data inputs to the sea ice concentration calculation algorithm are as follows:

- a. AMSR2 Level 1 products
 - 1) 6.925, 18.7, 23.8 GHz brightness temperatures (vertical polarization)
 - 2) 36.5 GHz brightness temperatures (horizontal and vertical polarizations)
 - 3) Latitude and longitude
 - 4) Incidence angle at the Earth surface
 - 5) Land / sea flags
- b. Auxiliary data
 - 1) Sea surface temperature (AMSR2 sea surface temperature product)

(2) Description of the algorithm

a. Selection of tie points, etc.

The algorithm identifies sea surface brightness temperatures and characterizes areas covered with 100 percent sea ice using the respective combinations of 36.5 GHz vertical-polarized and horizontal-polarized brightness temperatures and of

18.7 GHz and 36.5 GHz vertical-polarized brightness temperatures.

b. Identifying sea ice regions

The algorithm first identifies sea regions using the land / sea flag. It then identifies sea ice regions in sea regions. Sea ice regions are identified using four data sets: (a) the 18.7 GHz vertical-polarized brightness temperature and the difference between 23.8 GHz and 18.7 GHz vertical-polarized brightness temperatures, (b) the 36.5 GHz vertical-polarized and horizontal-polarized brightness temperatures, (c) the 36.5 GHz and 6.925 GHz vertical-polarized brightness temperatures, and (d) the AMSR2 sea surface temperature product.

c. Estimating the sea ice concentration

The sea ice concentration is calculated using the Bootstrap method from the 36.5 GHz vertical-polarized and horizontal-polarized brightness temperatures and the 18.7 GHz and 36.5 GHz vertical-polarized brightness temperatures. First, the algorithm estimates the sea ice concentration in high concentration areas using the 36.5 GHz vertical-polarized and horizontal-polarized brightness temperatures. Next, it estimates concentrations in other areas using the 18.7 GHz and 36.5 GHz vertical-polarized brightness temperatures.

d. Land region filter

In coastal regions, the effect of land can cause elevated sea ice concentration estimates. For this reason, the algorithm corrects sea ice concentration estimates in coastal regions using a land region filter.

4.3.1.8 Soil moisture content

(1) Input data

The data inputs to the soil moisture content calculation algorithm are as follows:

a. AMSR2 Level 1 products

- 1) 10.6 GHz brightness temperatures (horizontal and vertical polarizations) and 36.5 GHz brightness temperatures (horizontal polarization)
- 2) Latitude and longitude
- 3) Observation date

b. Auxiliary data

- 1) Global vegetation coverage ratios

(2) Description of the algorithm

Vegetation is widely distributed on land. Because vegetation holds a large amount of moisture, it is essential to assess vegetation effects on microwave emission paths in order to estimate soil moisture content from satellite data. The soil moisture content algorithm's method uses the polarization index (PI) and the index of soil wetness (ISW), which are found from brightness temperatures in the 10 GHz and 36 GHz bands, and a predefined look-up table (LUT) to estimate the soil moisture and vegetation moisture simultaneously. PI and ISW are defined as values after removing polarization differences or frequency differences, respectively, by averaging using the following equations.

$$PI = \frac{TB_{10v} - TB_{10h}}{\frac{1}{2}(TB_{10v} + TB_{10h})}$$

$$ISW = \frac{TB_{36h} - TB_{10h}}{\frac{1}{2}(TB_{36h} + TB_{10h})}$$

In these equations, TB refers to brightness temperature, the subscripts 10 and 36 refer to the frequency band (10.6 GHz and 36 GHz), and the subscripts v and h refer to vertical polarization and horizontal polarization. Because these indices are normalized through averaging to minimize the effect of physical temperatures, the algorithm omits processing physical temperatures by using a fixed value instead. The LUT is used to correct, with vegetation coverage ratios, non-uniform vegetative cover within the footprint.

4.3.2 Level 3 Process

The Level 3 process uses as its inputs one day's worth of Level 1B data and Level 2 data and calculates, by taking a simple arithmetic mean, the daily statistical mean value at each grid point in the specified mapping projection method (either equi-rectangular or polar stereo). Furthermore, Level 3 processing takes one month's worth of each geophysical parameter's Level 3 daily statistical mean values and calculates the monthly statistical mean value at each grid point using a simple arithmetic mean in the same way as the daily statistical mean calculation. The statistical means are calculated separately for observations along the satellite's ascending and descending tracks. Also, two dummy data values are used. The dummy value -9999 is used to fill in observation data where packets have been lost for some reason. The dummy value -8888 indicates grid points outside of the observation range or grid points where map projection data does not exist.

4.3.2.1 Polar stereo projection mappings

A projection method, either equi-rectangular or polar stereo, is selected for each AMSR2 Level 3 product. One of three regions can be selected when polar stereo projection is used. The resolution can also be selected from high resolution (0.1 degrees or 10 kilometers) or low resolution (0.25 degrees or 25 kilometers). Table 4-10 lists the current projection methods and lattice grid sizes available for AMSR2 Level 3 products.

Table 4-10: AMSR2 Level 3 product projection methods and lattice grid sizes

		High Resolution (0.1°, 10 km)		Low Resolution (0.25°, 25 km)	
		Pixels	Lines	Pixels	Lines
Projection method*	PN (SIC)	760	1120	304	448
	PN (SND)	1080	1435	432	574
	PS	790	830	316	332
	EQR	3600	1800	1440	720

*PN (SIC): Polar stereo projection of northern latitudes, sea ice concentration

PN (SND): Polar stereo projection of northern latitudes, snow depth

PS: Polar stereo projection of southern latitudes

EQR: Equi-rectangular projection

4.4 Project Formats

For details of the AMSR2 Level 1, 2, and 3 product formats, see the Annex to this document, which gives the specifications of the following formats.

- AMSR2 Level 1A format description
- AMSR2 Level 1B product format description
- AMSR2 Level 1R product format description
- AMSR2 Level 2 product format description
- AMSR2 Level 3 format description

4.5 Data Calibration and Verification

The GCOM-W1 onboard AMSR2 multi-spectral microwave scanning radiometer makes observations of global water properties. Its 16 channels, covering six

frequencies between 6.9 GHz and 89 GHz, observe brightness temperatures that reach the satellite. The radiometer derives geophysical parameter products through combinations of multi-channel brightness temperatures, based on scientific knowledge. The GCOM-W1 mission is to generate and supply global brightness temperatures and geophysical parameter products on a regular and frequent basis, to assess and predict global hydrological cycle changes and long-term climate changes, and to assist on-site applications. This requires the generation of data sets that are uniform globally and have stable, long-term accuracy. Another critical factor is consistency with geophysical parameters generated from other satellite-borne microwave scanning radiometers and other sensors operating concurrently with AMSR2.

A series of GCOM calibration and verification processes are used to reach the data quality described above. These processes include pre-launch ground testing and sensor model creation, on-orbit data assessments and calibrations after launch, accuracy assessments of calculated geophysical parameters, and public release of accuracy assessment results.

Table 4-11 gives the overall schedule of the calibration and verification processes.

Table 4-11: Overall AMSR2 schedule

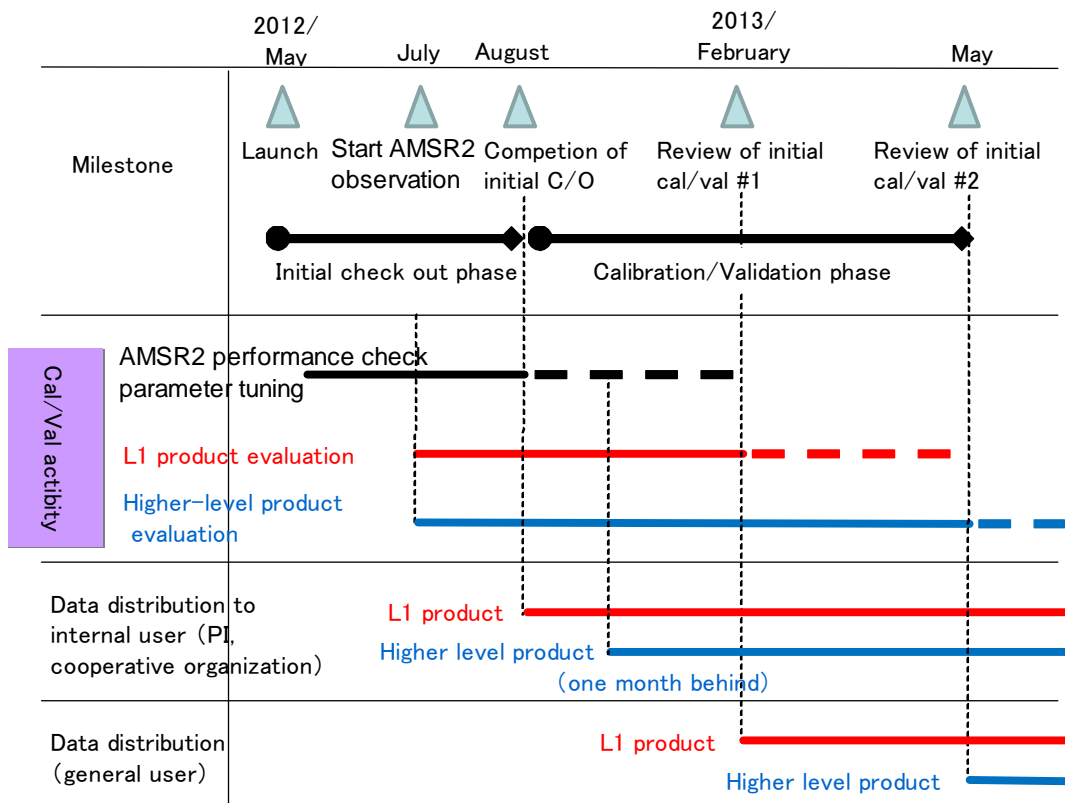

4.5.1 Calibrations

4.5.1.1 Description of the calibration plan

The calibration plan includes ground tests and sensor model construction in the design and development phase before launch. During the post-launch initial calibration and verification phase, there are on-orbit calibrations, combined and reciprocity calibrations, assessments of sensor characteristics and data quality, and geometric calibrations among others. And in the regular assessment stage, calibration data is monitored regularly.

Table 4-11 gives the calibration schedule.

4.5.1.2 Calibrated parameters

(1) Design and development phase

In conjunction with the sensor design and development, this phase identifies sensor characteristics associated with calibration, reflects those characteristics in the scope of ground tests and analyses, and examines corrective measures as needed. The results of these examinations form the crux of the satellite project and are incorporated into the sensor model used for brightness temperature conversions and geometric conversions, which are inputs to the Level 1 (brightness temperature) processing algorithm. When the sensor's ground tests and analyses are completed, the sensor characteristics and corrective measures are reexamined based on the testing/analysis results and the sensor model's coefficients are worked out. After this, the sensor model that will be used in the initial calibration and verification phase is settled on and merged into the Level 1 processing algorithms.

(2) Initial calibration and verification phase

a. Brightness temperature calibration

There is no single approach that can realistically and absolutely evaluate the sensor in order to calibrate brightness temperatures. For this reason, the final calibration is determined after assessing the overall consistency of results from a number of calibration evaluation measures, described in the following sections.

1) On-orbit calibrations

The basic on-orbit calibration is a two-point calibration using low-temperature and high-temperature calibration data. The first step is assessing the calibration source data in comparison with various kinds of telemetry information and ascertaining the

sources' characteristics. When the characteristics are already expressed in the sensor model, the model can be optimized by adjusting the relevant coefficients in the model. Other confirmed characteristics are evaluated and modeled separately. Examples of adjustments include eliminating contributions from non-deep space entities — such as the Earth, the moon, and the satellite fuselage — from the cold sky mirror data, and modifying the model to calculate the effective brightness temperature from the high-temperature noise source's temperature telemetry data. The brightness temperature obtained as a result of the two-point calibration is assessed together with the results of the sensor reciprocity calibration, described below. Further correction is added as needed.

2) Combined and reciprocity calibrations

Because no ideal target exists above the Earth for absolute calibration, reciprocity calibration is carried out with other similar microwave scanning radiometers operating concurrently. Calibration values are verified through comparisons with earth observation and other sensor observation data and the results of emission path calculations.

3) Sensor characteristics and data quality assessments

Sensor characteristics, such as intra-scan and inter-scan biases, individual receiver differences (89 GHz A + B channels, 6.9 + 7.3 GHz, etc.), temperature resolution, and gain stability, are studied through statistical processing of actual observation, calibration, and telemetry data. Sensor characteristics are assessed in combination with deep-space calibrations and combined calibrations. The global distribution and frequency of outliers caused by RFI and other interference are also found and methods are determined to adequately eliminate the outliers.

4) Deep-space calibrations (reference)

Deep-space calibrations are generally not done because of the risk of accidents due to capturing radio waves from stationary and polar orbit satellites. Nevertheless, the functionality is available, and deep-space calibrations can be conducted if necessary for calibration purposes. Observations of the deep-space temperature obtained during the deep-space calibration maneuver are used for absolute low-temperature calibration, intra-scan bias estimates and correction, and spillover estimates (TBD). These results are assessed in combination with other calibration results.

b. Geometric calibration

The geometric accuracy of the sensor is judged by comparing observation data from each channel with map information of preselected coastlines and islands. The results are used to adjust alignment information in the sensor model and registration parameters between frequencies, thereby correcting the geometric accuracy of the sensor.

c. Level 1 processing software optimizations

The results obtained from the calibration operations described above are incorporated in the sensor model and Level 1 processing software in order to optimize the model and software.

(3) Regular assessment phase

The calibration operations done in the initial calibration and verification phase, as described above, are repeated on a periodic basis. In addition, the long-term data accuracy and stability are assessed by regular monitoring of telemetry data associated with calibrations, calibration data, and brightness temperatures over specific regions, such as tropical rainforests, ice sheets, and open seas. There are also situations where trend analyses of geophysical parameters are fed back into the brightness temperature calibrations.

(4) Collaboration with international calibration and verification frameworks

We carry out efficient reciprocity calibrations and information exchanges by making use of international frameworks such as CEOS/WGCV and GPM.

4.5.2 Verifications

4.5.2.1 Description of the verification plan

The primary objectives of the AMSR2 verification plan are to define quantitatively the accuracy of each product, to create products with the required accuracy, and to improve algorithms when necessary.

Table 4-12 gives the designed accuracy for each AMSR2 geophysical parameter (product).

Table 4-12: Designed accuracy for each AMSR2 geophysical parameter

Product ¹	Observation Region	Spatial Resolution (approx. value)	Accuracy ²			Observation Range	Remarks	
			Release ³	Standard ⁴	Target ⁵			
Brightness temperatures (six frequencies, two polarizations)	Global	5–50 km	±1.5K	±1.5K	±1.0K ±0.3K	2.7 – 340K	Systematic error (max. amplitude, 150K equivalent) Variable error (3σ, 150K equivalent)	
Geophysical parameters	Total Precipitable Water	Global oceans	15 km	±3.5 kg/m ²	±3.5 kg/m ²	± 2.0 kg/m ²	0 – 70 kg/m ²	Vertically Total Precipitable Water , areas of sea ice and active precipitation are excluded.
	Cloud liquid water	Global oceans	15 km	±0.10 kg/m ²	±0.05 kg/m ²	±0.02 kg/m ²	0 – 1.0 kg/m ²	Vertically integrated cloud liquid water, areas of sea ice and active precipitation are excluded.
	Precipitation	From tropical to temperate zones	15 km	Over seas ±50% Over land ±120%	Over seas ±50% Over land ±120%	Over seas ±20% Over land ±80%	0 – 20 mm/h	Volume of precipitation at the Earth surface. Accuracy given as the average relative error in 50 km (percentage of RMSE for the average precipitation intensity).
	Sea surface temperature	Global oceans	50 km	±0.8°C	±0.5°C	±0.2°C	-2 – 35°C	Areas of sea ice and active precipitation are excluded. Target accuracy is the monthly average bias value for every 10 degrees of latitude.
	Sea surface wind speed	Global oceans	15 km	±1.5 m/s	±1.0 m/s	±1.0 m/s	0 – 30 m/s	Areas of sea ice and active precipitation are excluded.
	Sea ice concentration	High-latitude regions	15 km	±10%	±10%	±5%	0 – 100%	Accuracy is expressed in sea ice concentration [%].
	Snow depth	Land	30 km	±20 cm	±20 cm	±10 cm	0 – 100 cm	Areas of ice sheets and dense forests are excluded. Accuracy is expressed in snow depth and is the average absolute value error in instantaneous values.
	Soil moisture content	Land	50 km	±10%	±10%	±5%	0 – 40%	Volumetric water content in global land regions (including dry regions and cold regions) where the vegetation coverage water content equivalent is 2 kg/m ² or less. Areas of ice sheets and dense forests are excluded. Accuracy is the average absolute value error in instantaneous values.

- *1. Brightness temperatures are the most basic observation quantity converted from the sensor's engineering value outputs. All other geophysical parameters are derived from brightness temperatures via conversion algorithms.
- *2. Unless specifically noted otherwise, the stated accuracies are the root mean square error (RMSE) of instantaneous values. The accuracy of brightness temperatures is dependent on the accuracy of onboard and ground processing calibrations. The accuracy of other geophysical parameters is dependent on the brightness temperature accuracy, the conversion algorithm's performance, and the verification methods.
- *3. The minimum accuracy of data that can be released for use in climate change analyses.
- *4. A useable and standard level of accuracy based on past experience with AMSR, AMSR-E, etc.
- *5. An accuracy level that contains many research components, such as algorithm performance and calibration accuracy improvements.

4.5.2.2 Parameter descriptions

Table 4-13 provides descriptions of the products.

Table 4-13: Product descriptions

Product		Description
Total Precipitable Water (total precipitable water)	TPW	Total volume of water vapor in the atmosphere integrated in the vertical direction
Cloud liquid water	CLW	Total volume of cloud liquid water in the atmosphere integrated in the vertical direction
Precipitation	PRC	Hourly rainfall depth of liquid precipitation (rain) at the ground surface
Sea surface temperature	SST	Water temperature several millimeters below the sea surface penetrated by microwaves (near-skin sea temperature)
Sea surface wind speed	SSW	Wind speeds 10 meters above the sea surface
Sea ice concentration	SIC	Ratio of the area occupied by sea ice when sea water and sea ice exist in the 18 GHz band's observed field of view
Snow depth	SND	Depth of accumulated snow
Soil moisture content	SMC	Volumetric water content in surface soil

4.5.2.3 Product verifications

The purpose of verifications is to assess the accuracy of the geophysical parameter products. Verifications are made by comparing actual measurements from ground observations with AMSR2 calculated values. Collaborations with worldwide meteorological and oceanographic observation institutions and research projects provide various actual measurement data taken regularly at locations around the world. These data sets are used effectively to assemble verification data along with observation experiments for a given geophysical parameter.

Table 4-11 gives the verification schedule.

(1) Total Precipitable Water

The Total Precipitable Water product stores the total volume of water vapor in the atmosphere integrated in the vertical direction. The Total Precipitable Water product is primarily verified using the worldwide radiosonde network. If necessary, terrestrial microwave scanning radiometers installed on outlying islands and land-based global positioning system (GPS) receivers are used for verifications. Other verifications include reciprocal comparisons with other global precipitation measurement (GPM) mission satellites' observations and quality studies using on-site numerical forecasting systems.

The specific verification methods are described below.

AMSR2 estimated values for Total Precipitable Water are compared with Total Precipitable Water values calculated from atmospheric temperature, atmospheric pressure, and relative humidity data obtained from radiosondes. The worldwide radiosonde data used is standard isobaric surface data and data including singular points delivered by the global telecommunication system (GTS). Because AMSR2 estimates exist only over sea regions, radiosondes are selected that are free of land emission effects, such as those installed on islands with small land areas. Data sets where the radiosondes and the AMSR2 footprint match temporally and spatially are created and verified regularly. Matching data sets for observation data are also created and verified.

(2) Cloud liquid water

The cloud liquid water product stores the total volume of cloud liquid water in the atmosphere integrated in the vertical direction. The cloud liquid water product is verified with terrestrial (maritime) microwave scanning radiometer observation data and quality assessments that combine data from visible and infrared sensors. The problem is cloud liquid water is one of the most difficult geophysical parameters to verify quantitatively. Cloud liquid water can be measured with radiosondes or with aircraft, but the spatial distribution of clouds is discrete and subject to extreme temporal fluctuations. As well, radiosonde observations are single-point, and aircraft observations are limited in terms of their range and observation frequency. Furthermore, these observations are not quantitatively perfect. As for estimates of cloud liquid water with terrestrial microwave radiation observations, although indirect remote sensing methods, their observation background is cosmic background radiation. Therefore, because the observations are stable and uniform, they are more accurate than estimates from satellite orbits. And by adding vertical direction information from ceilometers and cloud radar, it is possible to further

improve the accuracy of cloud liquid water estimates. Reciprocal comparisons are made with other GPM satellite observations and on-satellite cloud radar observations. Comparisons are also made with analytic values from on-site numerical forecasting systems.

The specific verification methods are described below.

- a. The cloud liquid water product is assessed and verified with visible and infrared sensor data, such as the Second-Generation Global Imager (SGLI), the Moderate Resolution Imaging Spectroradiometer (MODIS), and the Visible Infrared Imaging Radiometer Suite (VIIRS), or with Level 3 data sets associated with clouds.
- b. AMSR2 data is matched and verified with terrestrial microwave scanning radiometers.
- c. The cloud liquid water product is verified through comparisons with cloud radar observations and on-satellite cloud radar observations.

(3) Precipitation

The precipitation product stores hourly rainfall depths of liquid precipitation (rain) at the ground surface. The monthly product stores monthly accumulated rainfall depths. Precipitation is a geophysical parameter that is difficult to compare directly with terrestrial observation data because it is subject to extreme temporal and spatial fluctuations. Basic verifications use existing terrestrial radar networks and terrestrial rain gauge clusters, but in view of the accuracy and uniformity of terrestrial data itself, it is very important to compare the product with on-satellite precipitation radar if the operating cycles can be matched.

The specific verification methods are described below.

- a. Comparisons with terrestrial radar networks and terrestrial rain gauges
The precipitation product is verified through comparisons with data from terrestrial radar networks and terrestrial rain gauge clusters located in Japan, the United States, Europe, and elsewhere. Comparisons with Japan's radar AMeDAS are linked to the verification plans of the highly accurate, high-resolution Global Satellite Mapping of Precipitation (GSMaP) and the GPM's global precipitation map.
- b. Comparisons with on-satellite precipitation radar
When on-satellite precipitation radar is operating concurrently with AMSR2, such as precipitation radar on Tropical Rainfall Measurement Mission (TRMM) satellites or dual-frequency precipitation radar on GPM satellites, verifications will be made through regular comparisons with these data sets.

c. Participation in international precipitation comparison experiments

Our participation in international precipitation comparison experiments — such as the Program to Evaluate High Resolution Precipitation Products (PEHRPP) run by the International Precipitation Working Group (IPWG), a part of the Coordination Group for Meteorological Satellites (CGMS) — will help in verifying a consistent precipitation product.

(4) Sea surface temperature

The sea surface temperature product stores water temperature several millimeters below the sea surface penetrated by microwaves (near-skin sea temperature). AMSR2 sea surface temperatures are assessed and verified using water temperature data from fixed and drift buoys deployed worldwide.

The specific verification methods are described below.

GTS fixed and drift buoy data will be retrieved daily online and a matching data set with AMSR2 data will be created automatically. This matching data set will be used to evaluate the product using buoy water temperatures as a reference as well as to find the frequency distribution of AMSR2 sea surface temperatures and their correlation with other geophysical parameters. A system should be constructed capable of updating the daily comparisons with buoy water temperatures and displaying and releasing the results. Furthermore, comparisons with sea surface temperatures from on-satellite infrared radiometers operating concurrently will be used for global surface verifications especially during the initial observation phase and for assessments of the global distribution of characteristics and errors in both data sets.

(5) Sea surface wind speed

The sea surface wind speed product stores wind speeds 10 meters above the sea surface. AMSR2 sea surface wind speeds are verified using wind speed data from fixed buoys deployed worldwide.

The specific verification methods are described below.

During the initial phase (the first six months or so after launch), verifications will use wind speed data from fixed buoys obtained via GTS. GTS fixed buoy data will be retrieved daily online and a matching data set with AMSR2 data will be created automatically. After the initial phase (from six months to a year after launch), matching data sets will be created using fixed buoy wind speed data from the U.S. National Data Buoy Center (NDBC), which is available over the Internet. These matching data sets will be used to evaluate the product using buoy water

temperatures as a reference as well as to find the frequency distribution of AMSR2 sea surface wind speeds and their correlation with other geophysical parameters. Comparisons will also be made with any on-satellite microwave scatterometers operating concurrently.

(6) Sea ice concentration

The sea ice concentration product stores the ratio of the area occupied by sea ice when sea water and sea ice exist in the 18 GHz band's observed field of view. A large portion of sea ice regions shift daily due to the influence of winds and ocean currents, while other regions are a mixture of young ice, first-year ice, and multi-year ice. Whether using the Bootstrap algorithm, the standard AMSR2 sea ice concentration estimation algorithm, or the NASA Team 2 algorithm, NASA's standard AMSR-E algorithm, what is important is setting the algorithm's parameters based on the distributions of first-year ice, multi-year ice, and open sea in a given space using observation data. Because these distributions vary depending on the sensor, the season, and the sea region, it is necessary after launch to create distributions in specific segments in the South Pole, the North Pole, the Sea of Okhotsk, and other sea ice regions and then adjust the algorithm's parameters based on these distributions. It is also imperative to assess atmospheric and land influences. These influences are assessed using observation data and the algorithm parameters are adjusted appropriately. Because atmospheric effects in particular have large regional differences and seasonal variations, separate verifications must be made for each sea ice region and for summer and winter. In polynya and ice fringe regions where thin ice dominates, the estimation accuracy declines. Detailed observations of sea ice in these regions have not been possible until now because the emission characteristics are very changeable as the ice grows. Therefore, it is important to ascertain through observations the emission characteristics in each frequency band of sea ice in polynya and ice fringe regions in order to raise the accuracy of concentration estimates.

The specific verification methods are described below.

Sea ice concentrations are verified primarily through comparisons with optical sensors. The optical sensor data that will be used comes from Aqua / MODIS, which is part of the same A-Train as GCOM-W1. The presence or absence of sea ice is determined from MODIS and other high-resolution images. This information is used to create sea ice concentration data closely aligned to the AMSR2 observation regions, which are then compared with the product. A data set of graded ground truth data is built up using sea ice concentration data from MODIS

images and from ship and ice flow sea ice observations, aircraft observations, and multistage observations that synchronize Terra, Aqua, and other satellite observations. The same process was used for the development of the algorithm. The presence or absence of sea ice is classified based on the created data set. Comparisons are made in the Sea of Okhotsk and in the summer and winter North Pole and South Pole. The algorithm is verified and the effects of land and atmosphere assessed through comparisons with satellite data sets with resolutions 10 or 20 times higher than AMSR2 data. To fully optimize parameters with a large influence on sea ice concentration estimate accuracy, variations due to the sea region and season are assessed and used to fine tune the parameters. This necessitates cooperation with various related institutions to carry out regular ongoing verifications in multiple sea regions instead of only a short verification immediately after launch.

Polynya and ice fringe regions are particularly important in raising the estimation accuracy. Tie points in each sea ice type will be verified and applied in comparison with other satellites and in consideration of sea ice emission characteristics obtained with on-site observations around Monbetsu harbor, Lake Saroma, and sea ice regions at both poles.

(7) Snow depth

The snow depth product stores the depth of accumulated snow. The verification plan, which accounts for the following three effects, is essential to verifying the snow depth estimation algorithm.

a. Verification under various accumulated snow conditions (snow particle size and layer composition)

Variations in snow particle size and layer composition, caused by changes in the snow composition, have a huge impact on the microwave emission path characteristics. Consequently, the product must be verified under conditions that give these different microwave emission path characteristics.

b. Verification accounting for the microwave characteristics of the surface under the snow

The microwave emission and dispersion characteristics of the surface under the snow present a boundary condition for the microwave emission path equation within the accumulated snow layer. The lower boundary condition in the microwave emission path equation changes noticeable between regions where the surface is

thawing even in winter, regions where there is no melted snow under the snow layer, and regions where accumulated snow has fallen after the soil has frozen. Consequently, the product must be verified with different underlying surface conditions and under the various accumulated snow conditions.

- c. Verification under various vegetation conditions (amount and type of vegetation, snow in tree canopies, and the non-uniformity of vegetation cover)

How the moisture contained in vegetation is distributed over the accumulated snow — namely, vegetation biomass, structure of tree branches and trunks, accumulated snow in tree canopies, and unevenness of vegetation distribution in the footprint — is known to have a large impact on the microwave emission path. Consequently, the product must be verified with different vegetation conditions as well as under the various conditions given above.

The specific verification methods are described below.

Verifications 1) and 2) below are combined in order to verify the product under all the conditions discussed above and verification 3) is run as needed to enhance the algorithm.

- 1) Focused verifications and observation tests in areas the size of the satellite's footprint

First, a long-term observation system will be built on an accessible 25-kilometer square of featureless terrain where multiple auto snow depth measurement devices and auto weather observation devices are installed. This observation data will be compared with the satellite's product. Other detailed studies will be made with human observations of the snow density, particle size, layer composition, underlying surface temperature, soil moisture, and vegetation from the start of the snowfall season to the thawing season.

- 2) Verifications with long-term observation data under various climate conditions

Verification tests will be conducted over a long period under different climates, vegetation, snow conditions, and soil conditions. Regions described in 1) above should be selected for their comparative uniformity of conditions so that point observations are valid over the entire area.

- 3) Terrestrial microwave scanning radiometer observations and verifications under well-managed conditions

We will collect and examine highly accurate observation data using terrestrial scanning radiometers with the same performance levels as satellite sensors on a scale that permits quantitative measurements of snow conditions, underlying surface characteristics, and vegetation conditions.

(8) Soil moisture content

The soil moisture content product stores the volumetric water content in surface soil. The verification plan, which accounts for the following four effects, is essential to verifying the soil moisture content estimation algorithm.

a. Verifications under soil moisture conditions from arid to damp

In damp conditions, the microwave emission path characteristics are determined by the surface emissivity (the surface dielectric constant and surface dispersion characteristics are important; soil moisture is one of the main factors determining the dielectric constant) and the surface temperature. Conversely, in arid conditions, the microwave emission path characteristics (volume scattering) in the soil layer and the soil temperature's vertical profile dominate. Consequently, the product must be verified under conditions that give rise to these different emission path characteristics.

b. Verifications with different soil types (surface roughness and texture)

The surface dispersion characteristics — largely determined by the surface roughness, and the volume scattering in the soil layer — largely determined by differences in texture, have a big impact on microwave emission path characteristics. Consequently, the product must be verified under different surface roughness and texture conditions and simultaneously under a broad range of soil moisture conditions, from arid to damp.

c. Verification under various vegetation conditions (amount and type of vegetation and the non-uniformity of vegetation cover)

How the moisture contained in vegetation is distributed over the surface — namely, vegetation biomass, structure of leaves and stems, and unevenness of vegetation distribution in the footprint — is known to have a large impact on the microwave emission path. Consequently, the product must be verified with different vegetation conditions as well as under the conditions given in a. and b. above.

d. Verification under conditions of non-uniform soil moisture distributions within the

footprint

Actual soil moisture distributions are not even, but are known to change and be distributed unevenly due to rainfall distributions, surface coverage, and microtopography. As the satellite footprint is on the order of tens of kilometers, the product must be verified in areas of that scale.

The specific verification methods are described below.

Verifications 1) and 2) below are combined in order to verify the product under all the conditions discussed above and verification 3) is run as needed to enhance the algorithm. To help promote use of the product, verifications 4) and 5) will be used to judge the product's accuracy and quality more rigorously.

1) Long-term data collection in a verification region equivalent in size to the satellite footprint

First, a long-term observation system will be built on an accessible 10-kilometer or so square of featureless terrain where multiple auto soil moisture measurement devices and auto weather observation devices are installed. This observation data will be compared with the satellite's product.

2) Verifications with long-term observation data under various climate conditions

Verification tests will be conducted over a long period in different climates, vegetation conditions, and soil types. In order to compare and evaluate various regions around the world, locations are selected, in addition to the conditions in 1) above, for their comparative uniformity of conditions so that point observations are valid over the entire area.

3) Terrestrial microwave scanning radiometer observations and verifications under well-managed conditions

We will collect highly accurate observation data using terrestrial scanning radiometers with the same performance levels as satellite sensors on a scale that permits quantitative measurements of wetness conditions, soil characteristics, and vegetation conditions. The observation data is used to examine algorithm enhancements.

4) Reciprocal verifications with other satellite products and model outputs

We will move ahead with reciprocal verifications with other soil moisture products and numeric climate model outputs.

5) Examinations of verification methods of areas on the scale of the footprint

We will examine the definitions of soil moisture in areas on the scale of the footprint when soil moisture is unevenly distributed and examine more effective satellite verification methods.

4.5.2.4 Algorithm verifications

Calculation algorithms are improved as needed based on the results of product verifications. See Section 4.3.1 for details on the algorithms.

Chapter 5 Data Providing Service

Products for general researchers are supplied with the GCOM-W1 data providing service,¹ which uses the GCOM-W1 Data Provision Subsystem (DPSS). This chapter details the range of data provided with this system and describes the basics of the system. For more details about the service, see the guide “How to Use the GCOM-W1 Data Providing Service for Beginners to Satellite Data Usage”² on the JAXA website.

5.1 Product Storage

The table below lists the data provided through this service. The service supplies the most recent generation of Level 1 (L1) data and the two most recent generations of Higher-level processed products (Level 2 (L2) and Level 3 (L3)).

Table 5-1: List of supplied data

Satellite	Data Type	Observation Period	Generation
ADEOS-II	AMSR standard products	2003/04/02 to 2003/10/24	—
Aqua	AMSR-E standard products	2002/06/01 to 2011/10/04	—
GCOM-W1	AMSR2 standard products	Five years from 2012/5/18	L1: Most recent generation L2/L3 : Two most recent generations
	Associated information (track information, satellite and sensor operation information, user toolkit, etc.)	—	—

Note: Version information displayed in the service’s catalog details and elsewhere uses letters after reaching Version 9. For example: 1, 2, 3, ... 9, A, B, ...

¹ <https://gcom-w1.jaxa.jp/auth.html>

² <https://gcom-w1.jaxa.jp/Beginner.pdf>

DPSS stores and manages only the most recent versions of AMSR2 products. However, older versions of AMSR2 products stored and managed by the mission operation system can be supplied to users on request. When a user orders an older product version that is stored only at the mission operation system, the data will be provided from the mission operation system. DPSS also stores and manages all user AMSR and AMSR-E products.

This system does not handle research products or test products. Links are provided to the sites where these data sets are held.

5.2 Product Provision Policy

5.2.1 Data Policy

The GCOM-W1 data providing service supplies products to the public under the following conditions.

- (1) Users: all general researchers
- (2) Contract: no individual contracts (possible to automatically apply and sign up by agreeing to the online Terms of Use). Online sign-up requires the user's name, affiliation, and purpose of use, and JAXA reserves the right to collect information on the results of using its data.
- (3) Provided products: AMSR, AMSR-E, and AMSR2 observation data (standard products)
- (4) Provision method: online
- (5) Fees: free of charge provided that usage does not incur additional expenses to JAXA
- (6) Provision to third parties: not permitted

Standard products for general researchers are made available via DPSS within the times given in the table below based on processing performance and demand.

Table 5-2: Delivery of products for general researchers

Delivery Products	Time to Provision
Standard product	a. Level 1 products: within 12 hours of the observation start time
	b. Level 2 products: within 24 hours of the observation start time

Delivery Products	Time to Provision
	c. Level 3 products: within 24 hours of the final observation time of the products used in the Level 3 process (L3 monthly averages are available on the first day of the following month)

5.2.2 User Categories

The table below indicates the service's user categories. Users must register and become registered users in order to obtain products. Users can register online.

Table 5-3: User categories

Category	Definition	Usage Limitations / Privileges
Guest user	A user who has not completed user registration	Able to search data, but cannot place orders or obtain products.
Registered user	A user who has completed the online user registration	Able to search and order data. Data orders are limited to 1.5 GB per order. Possible to obtain products directly without placing an order.

Table 5-4: Service contents

Provided Services	User Type	
	Guest	Registered
User authentication	Yes	Yes
User registration	Yes	n/a
User info update	No	Yes
News and announcements	Yes	Yes
Product searches	Yes	Yes
Save and load search conditions	No	Yes
View on screen and check catalog	Yes	Yes
Ordering (including instant downloads)	No	Yes
Satellite and sensor operation	Yes	Yes

Provided Services	User Type	
	Guest	Registered
information		
No. of registered data records	Yes	Yes
Product descriptions	Yes	Yes
Product version histories	Yes	Yes
User manual (searching and ordering instructions)	Yes	Yes
Product version histories	Yes	Yes
Toolkit	Yes	Yes
Direct downloads of standard products	No	Yes
Help desk access		
Email inquiries (Japanese/English)	Yes	Yes
Fax inquiries (Japanese/English)	No	Yes
Telephone inquiries (Japanese)	No	Yes

5.2.3 Process Versions

The purpose of GCOM algorithm development is to conduct R&D into algorithms that generate geophysical parameters with sufficient precision for end applications, to implement systems, and to continually maintain and improve the algorithms. Alongside continuing to maintain the algorithm, test processes and verifications are run using real AMSR2 data and the results are released. Version 0 of a process algorithm is given when development is complete and Version 1 is given when data are released. After the first data release, the algorithm version will be updated roughly every 1.5 years for better product accuracy and for GCOM-W2.

As a result, products with different process versions are created for the same sensor / period / observation region. Generally, the service provides products processed with the latest algorithm. Therefore, users must pay attention to the process version. The process version can be identified with the product version, algorithm version, and parameter version appended to the file name (granule ID).

The granule ID assignment rules are given below.

(1) Granule ID assignment rules for AMSR2 Level 1 / Level 2 products

Scene ID	Product ID
Byte position	1 2 3 4 5 6 7 8 9 10 11 12 13 14 15 16 17 18 19 20 21 22 23 24 25 26 27 28 29 30 31 32 33 34 35 36 37 38 39 40 41
AMSR2	G W 1 A M 2 _ C C Y Y M M D D H H m m P P P X L L x x K K K r d v a a a p p p

<Example> G W 1 A M 2 _ 2 0 1 1 1 1 1 3 2 3 4 5 _ 0 1 2 D _ L 1 S G A D N R _ 1 1 0 1 0 0 1

Scene ID
 [Satellite] [Sensor] (Start date of observation) (Path number) (Ascending/Descending)
 Satellite code : GW1 (Fixed)
 Sensor Code : AM2 (Fixed)
 Start date of Obs. : CCYYMMDDHhm (Christian year (UT))
 Path number : PPP (000~300) *Path number at beginning of the observation
 Ascending/Descending : X (A: Ascending, D: Descending, B: Downlink unit (Both))

Product ID
 (Processing level) (Product type) (Product ID) (Resolution) (Developer ID) (Product ver.) (Algorithm ver.) (Processing parameter ver.)
 Processing level : LL (L1: level1, L2: level2)
 Product type : xx (SG: Standard product, SN: Near realtime processing product (Grobal), SL: Near realtime procesing product (Around Japan area), RG: Research product (Standard), RN: Research product (Near realtime (Grobal)), RL: Research product (Near realtime (Aroudn Japan area)))
 Product ID : KKK (<L1A> ADN: Digital Number, <L1B> BTB: Brightness Temperature, <L1R> RTB: Brightness Temperature, <L2> CLW: Cloud Liquid Water, TPW: Total Precipitable Water, PRC: Precipitation, SST: Sea Surface Temperature, SSW: Sea Surface Wind speed, SIC: Sea Ice Concentration, SND: Snow Depth, SMC: Soil Moisture Content)
 Resolution : r (<L1> R: Raw (Fixed), <L2> L: Low (Small number of observation point (243 points)), H: High (Large number of observation point (486 points)))
 Developer ID : d (<L1> _: Underscore (Fixed), <L2> A-Z)
 Version number of Product : v (0-9, a-z)
 Version number of algorithm : aaa (000-999)
 Version number of Processing parameter : ppp (000-999)

Figure 5-1: Level 1 / Level 2 granule ID assignment rules

(2) Granule ID assignment rules for AMSR2 Level 3 products

Scene ID	Product ID
Byte position	1 2 3 4 5 6 7 8 9 10 11 12 13 14 15 16 17 18 19 20 21 22 23 24 25 26 27 28 29 30 31 32 33 34 35 36 37 38 39 40 41
AMSR2	G W 1 A M 2 _ Y Y Y Y M M D D t t t P P W X L L x x K K K r d v a a a p p p

<Example> G W 1 A M 2 _ 2 0 1 1 1 1 1 3 _ 0 1 D _ E O O D _ L 3 S G T 8 9 H A 1 1 0 1 0 0 1

Scene ID
 [Satellite] [Sensor] (Start date of observation) (Calculating period) (Map projection) (Statistical method) (Ascending/Descending)
 Satellite code : GW1 (Fixed)
 Sensor code : AM2 (Fixed)
 Start date of obs. : YYYYMMDD (Christian year (UT), "DD"="00" means monthly data)
 Calculating period : ttt (01D: Daily, 01M: Monthly)
 Map projection : PP (EQ: Equirectangular, PN: Polar stereo (North hemisphere), PS: Polar stereo (South hemisphere))
 Calculating method : W (M: Mean, O: Overwrite)
 Ascending/Descending : X (A: Ascending, D: Descending)

Product ID
 (Processing level) (Product type) (Product ID) (Resolution) (Developer ID) (Product ver.) (Algorithm ver.) (Processing parameter ver.)
 Processing level : LL (L3: Level3)
 Product type : xx (SG: Standard product, RG: Research product)
 Product ID : KKK (T06: TB 6GHz, T07: TB 7GHz, T10: TB 10GHz, T18: TB 18GHz, T23: TB 23GHz, T36: TB 36GHz, T89: TB 89GHz)
 CLW: Cloud Liquid Water, TPW: Total Precipitable Water, PRC: Precipitation, SST: Sea Surface Temperature, SSW: Sea Surface Wind speed, SIC: Sea Ice Concentration, SND: Snow Depth, SMC: Soil Moisture Content
 Resolution (lattice) : r (L: Low (25km (0.25°)), H: High (10km (0.1°)))
 Developer ID : d (A-Z)
 Version number of Product : v (0-9, a-z)
 Version number of algorithm : aaa (000-999)
 Version number of Processing parameter : ppp (000-999)

Figure 5-2: Level 3 granule ID assignment rules

5.2.4 Terms of Use

The following Terms of Use for the service are given on the JAXA website. See the Terms of Use³ under Using This Site for the latest information. (*Quoted material is shown in italics.*)

The Japan Aerospace Exploration Agency (hereinafter referred to as "JAXA") provides free of charge products containing data from three satellite sensors — AMSR2 on the Global Change Observation Mission 1st-Water (GCOM-W1), AMSR on Midori II (ADEOS-II), and AMSR-E on Aqua — via the GCOM-W1 Data Providing Service (the "Service").

These terms stipulate the conditions users must observe when making use of the Service. People wishing to use the Service (the "users") are required to read the following terms and conditions and indicate their agreement before making use of the Service.

(1) Site Policy

The Site Policy of the Website (<https://gcom-w1.jaxa.jp>) on which the Service is hosted conforms to JAXA's Site Policy and Terms of Use (http://www.jaxa.jp/policy_j.html).

(2) User registration

User registration is necessary in order to make use of the Service. The Service's login uses an authentication method consisting of an email address (user account) and password. User registration requires the provision of the user's name, email address, organization, department, country or region, and purpose of data usage.

(3) Deletion of user registration

Users can delete their user registration by sending an email requesting deletion of the user registration to the GCOM-W1 Data Providing Service's Help Desk given at the end of the Terms of Use.

(4) Privacy protection and handling of private information

JAXA will handle registered user information (name, email address, organization, department, country or region, and purpose of data usage) in proper accordance

³ <http://gcom-w1.jaxa.jp/useagreement.html>

with JAXA's Rules on Privacy Protection.

For details, please see the JAXA Privacy Policy

(http://www.jaxa.jp/about/disclosure/kojin/index_j.html).

JAXA shall use registered user information only for the following purposes:

- Determination of data usage*
- User surveys and questionnaires to improve the Service*
- Respond to user inquiries*

JAXA outsources some parts of its services to other companies. Outsourced services include system management, user management, and help desk services. Contracted businesses do make use of user information as needed to carry out the services above, but user information is not used for any other purpose.

(5) Account and password management

Users are completely responsible for managing their user account and password. JAXA does not accept any responsibility whatsoever with regard to losses, damages, etc. that may arise due to the misuse of a user account or password by a third party.

(6) Ownership of data rights, etc.

JAXA is the owner of the copyrights and intellectual property rights of all data, including all products and image data, provided with the Service. Redistribution to third parties of any data obtained with this Service is strictly prohibited.

Use of the Service's data must comply with the terms and conditions set forth in JAXA's Site Policy and Terms of Use (http://www.jaxa.jp/policy_j.html).

Users may not use the Service's data for business activities, commercial activities, or similar purposes without prior consent of the copyright holder (JAXA). If you wish to use the Service's data for business activities or commercial activities, please contact the JAXA Industrial Collaboration and Coordination Center (<http://aerospacebiz.jaxa.jp>) beforehand.

(7) Cancellation of service usage

JAXA reserves the right to cancel and delete a user registration if the user has violated the Terms of Use or if the user is otherwise deemed inappropriate.

(8) Service changes

JAXA reserves the right to change or modify the Service's operating terms and

conditions, the Service content, the Terms of Use, etc. at any time. Changes to the Terms of Use will be notified by posting a statement on the Service website. Users accessing the Service the first time after the notification of the Terms of Use changes are asked to verify the new Terms of Use before using the Service.

(9) Service termination

JAXA reserves the right to terminate the Service at its own discretion.

JAXA will notify users about any Service termination beforehand by an appropriate method.

(10) Reporting findings

Please include the following statement in any published articles, reports, etc. that make use of products, image data, etc. supplied by the Service.

For reports in Japanese:

「本論文にて使用した AMSR2 データ (AMSR-E データおよび、AMSR データ) は、宇宙航空研究開発機構 GCOM-W1 データ提供サービスより提供を受けました。」

For reports in English:

“AMSR2 data (AMSR-E, AMSR data) were supplied by the GCOM-W1 Data Providing Service, Japan Aerospace Exploration Agency.”

The GCOM-W1 Data Providing Service's Help Desk collects materials that reference the Service's data. Please send a reprint or copy of any articles, reports, etc. that make use of the Service's data to GCOM-W1 Data Providing Service's Help Desk given at the end of the Terms of Use. We appreciate your cooperation.

You may send reprints or copies by mail, email attachment, fax, or any other means of your choice.

(11) Limitations on data orders

To ensure fair access to our limited network and computing resources for as many users as possible, JAXA limits the amount of data that can be downloaded per order per user account.

(12) Disclaimer

Although we strive to ensure the quality of all aspects of the Service, JAXA makes

no warrantee or guarantee about the safety, security, or reliability of provided information and does not accept any responsibility whatsoever with regard to losses, damages, etc. that may arise through the user's use of the Service or the Service's information.

JAXA reserves the right to change, modify, or delete information on the Service and to suspend or terminate the operation of the Service and does not accept any responsibility whatsoever with regard to losses, damages, etc. that the user may incur as a result of these actions.

(13) Inquiries

Questions or comments concerning any aspect of the service should be directed to the help desk below.

Contact : GCOM-W1 Data Providing Service's Help Desk
*Address : Tsukuba Space Center, Japan Aerospace Exploration Agency,
2-1-1 Sengen, Tsukuba, Ibaraki, 305-8505*
Office : 9:30 – 12:15
*hours : 13:00 – 17:45 (except Saturdays, Sundays, public holidays,
and year-end holidays (December 29 – January 3))*
Telephone : 050-3362-6599
Fax : 029-859-5574
Email : Z-gw1help@jaxa.jp

5.2.5 Data Searches and Orders

There are three different ways to search for and order data available with the service (Figure 5-3). See the GCOM-W1 Data Providing Service User Manual for detailed operating instructions.

(1) Select while following directions

Users can search for data specified through a wizard interface. The product, observation period and region, and other detailed search conditions are set while following directions on a wizard interface. Search conditions can be refined by Step 1: specifying the product by category, Step 2: specifying the period and region, Step 3: specifying other conditions such as version, quality, satellite, sensor, and pass number.

(2) Select by category / geophysical parameter

Users can search for data after specifying the category or geophysical parameter. The geophysical parameter, observation period, observation region, and other search conditions can be set on the same window.

(3) Select by satellite / sensor name

Users can search for data after specifying the satellite or sensor. The satellite / sensor name, observation period, observation region, and other search conditions can be set on the same window.

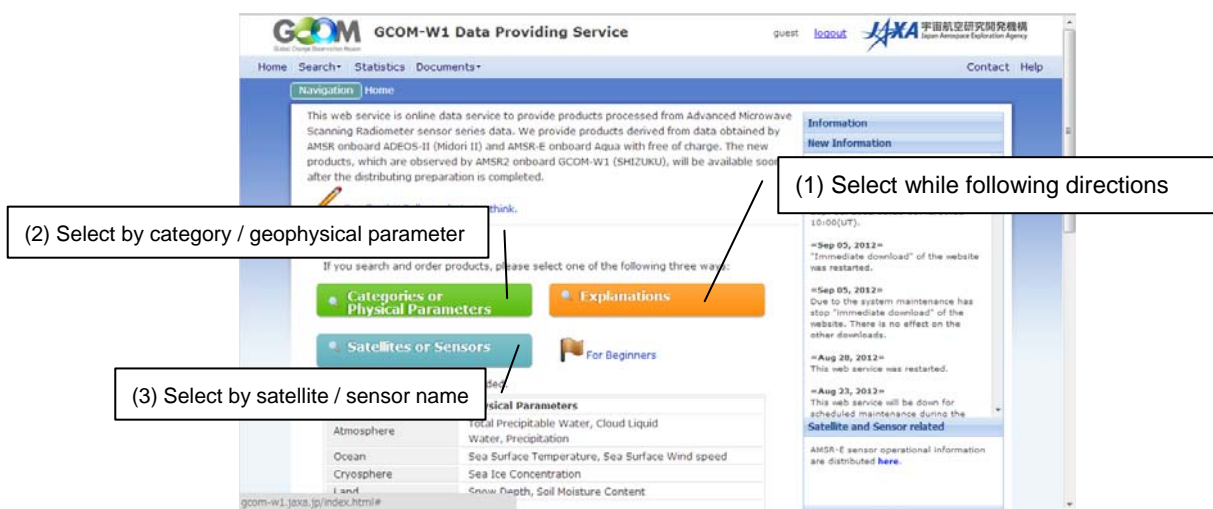

Figure 5-3: Search window (guest user)

5.3 User Tools

The core of the GCOM-W1 Data Providing Service is downloads of user-related information references and tools intended for general researchers using the service. User tools are generally distributed free of charge. While online help is available for the tools, user support is not offered.

Tools can be downloaded by accessing the respective sites given below. Users can obtain the AMSR / AMSR-E tools and the AMSR I/O toolkit with the Download Toolkit option on the GCOM-W1 Data Providing Service website. Users can obtain GCOM-W1 track elements and satellite information with the View Satellite / Sensor Operation Data option.

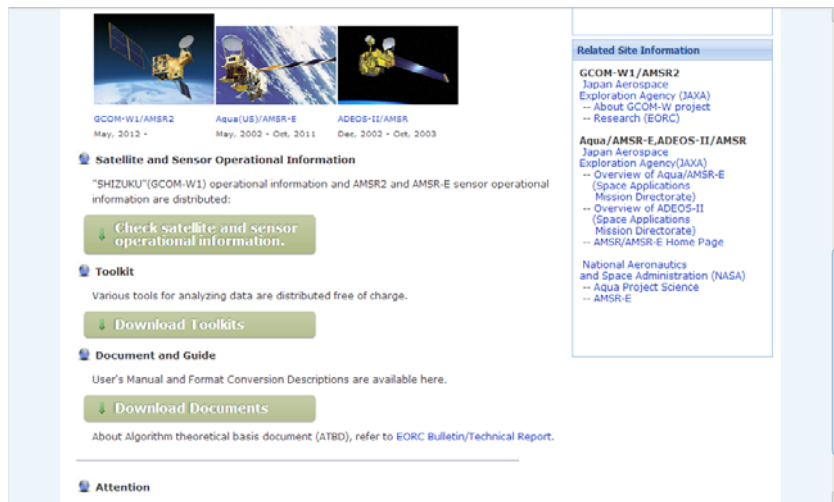

Figure 5-4: User tool acquisition methods (1 / 2)

Alternatively, users can obtain the AMSR / AMSR-E tools and the AMSR I/O toolkit from the Toolkit menu option and GCOM-W1 track elements and satellite information with the Satellite / Sensor Operation Data menu option from the site shown below.

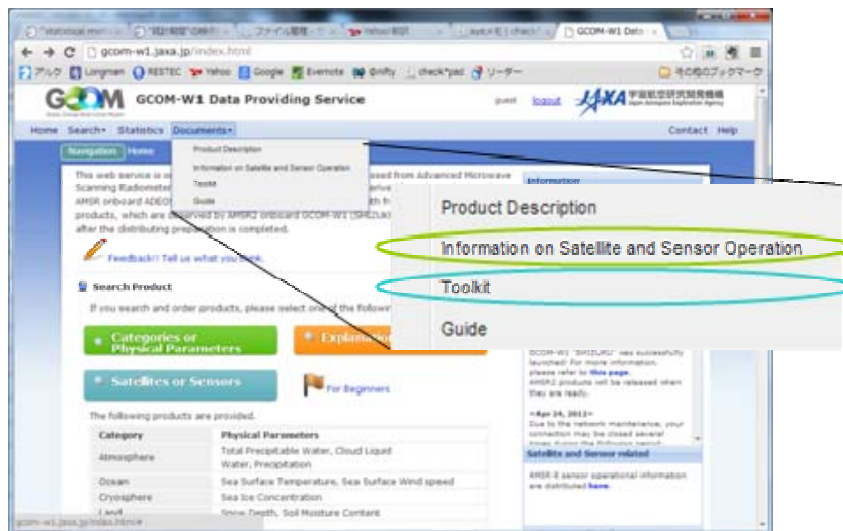

Figure 5-5: User tool acquisition methods (2 / 2)

Appendix 1 Acronyms

Acronyms	:	Description
ADM	:	Antenna Drive Mechanism
AGC	:	Auto Gain Control
AMSR2	:	Advanced Microwave Scanning Radiometer 2
AMSR-E	:	Advanced Microwave Scanning Radiometer for EOS
ASD	:	Apid Sorted Data
A-Train	:	The Afternoon Constellation
CALIPSO	:	Cloud-Aerosol Lidar and Infrared Pathfinder Satellite Observations
CEOS	:	Committee on Earth Observation Satellites
CGMS	:	Coordination Group for Meteorological Satellites
CLW	:	Cloud Liquid Water
CSM	:	Cold Sky Mirror
CWI	:	Cloud liquid Water Index
DPR	:	Dual-frequency Precipitation Radar
DPSS	:	Data Provision SubSystem
EQR	:	Equi-Rectangular Map Projection
GANAL	:	Global objective analysis data
GCOM	:	Global Change Observation Mission
GCOM-C	:	Global Change Observation Mission - Climate
GCOM-W	:	Global Change Observation Mission - Water
GCOM-W1	:	Global Change Observation Mission 1st-Water "Shizuku"
GEOSS	:	Global Earth Observation System of Systems
GPM	:	Global Precipitation Measurement
GPS	:	Global Positioning System
GSMaP	:	Global Satellite Mapping of Precipitation
GTS	:	Global Telecommunication System
HDF	:	Hierarchical Data Format
HTS	:	High Temperature Source
IPWG	:	International Precipitation Working Group
JAXA	:	Japan Aerospace eXploration Agency
JPSS	:	Joint Polar Satellite System
KSAT	:	Kongsberg Satellite Services AS
LUT	:	Look-Up Table

MGDSST	:	Merged satellite and in situ data Global Daily Sea Surface Temperatures in the global ocean
MODIS	:	MODerate resolution Imaging Spectrometer
MWA	:	Momentum Wheel Assembly
NASA	:	National Aeronautics and Space Administration
NDBC	:	National Data Buoy Center
NOAA	:	National Oceanic and Atmospheric Administration
OBE	:	Orbital Balancing Electronics
OBM	:	Orbital Balancing Mechanism
PDUC	:	Power Distributor Unit Control Unit
PDUS	:	Power Distributor Unit Sensor Unit
PR	:	Precipitation Radar
PS	:	Polar Stereo Map Projection
PWA	:	Precipitable Water Amount
PWI	:	Precipitable Water Index
RFI	:	Radio-Frequency Interference
RMSE	:	Root Mean Square Error
SGLI	:	Second generation Global Imager
SIC	:	Sea Ice Concentration
SMC	:	Soil Moisture Content
SND:	:	SNow Depth
SPC	:	Signal Processor Control Unit
SPS	:	Signal Processor Sensor Unit
SST	:	Sea Surface Temperature
SSW	:	Sea Surface Wind speed
TB	:	brightness temperature
TCC	:	Thermal Controller Control Unit
TCS	:	Thermal Controller Sensor Unit
TPW	:	Total Precipitable Water
TRMM	:	Tropical Rainfall Measuring Mission
VIIRS	:	Visible and Infrared Imager Radiometer Suite
WGCV	:	Working Group on Calibration and Validation
WGS84	:	World Geodetic System 1984

Appendix 2 Related Information

Appendix 2.1 Bibliography

- (1) Global Change Observation Mission Water (GCOM-W1) (Briefing document) (Japanese) (N/A)
- (2) AMSR2 Level 1 Algorithm Description Document (Japanese) (N/A)
- (3) Earth Observation Satellite Data Archive Policy (Japanese) (MAS-100037)
- (4) Global Change Observation Mission Water (GCOM-W1) Product Definition Document (Japanese) (NEB-090029)
- (5) Global Change Observation Mission Water (GCOM-W1) Validation and Verification Plan (Japanese) (NDX-070017)
- (6) Global Change Observation Mission Water (GCOM-W1) Verification Implementation Document (Japanese) (NDX-110017)
- (7) Algorithm Description of GCOM-W1 AMSR2 Precipitation Algorithm
- (8) Algorithm Description of GCOM-W1 AMSR2 Snow Depth Algorithm
- (9) Algorithm Description of GCOM-W1 AMSR2 Sea Ice Concentration Algorithm
- (10) Algorithm Description of GCOM-W1 AMSR2 Sea Surface Temperature Algorithm
- (11) Algorithm Description of GCOM-W1 AMSR2 Sea Surface Wind Speed Algorithm
- (12) Algorithm Description of GCOM-W1 AMSR2 Total Precipitable Water and Cloud Liquid Water Algorithm
- (13) GCOM-W1 MISSION OPERATIONS INTERFACE SPECIFICATION (M O I S)
- (14) Global Change Observation Mission Water (GCOM-W1) Ground System Operational Concept (Japanese) (SGC-070079)
- (15) Global Change Observation Mission Water (GCOM-W1) Routine Operation Baseline Document (Mission Operation) (Japanese) (N/A)
- (16) GCOM-W1 Mission Operation system Interface Control Document (Draft) (Japanese) (DSD-800774-B02C)
- (17) Global Change Observation Mission Water (GCOM-W1) System development for Data Provision Subsystem and its operation Operational Document (Japanese)

Appendix 2.2 Relevant Websites

■ JAXA's site

- (1) JAXA website

<http://www.jaxa.jp/>

- (2) Global Change Observation Mission 1st – Water “SHIZUKU” (GCOM-W1) website

http://www.jaxa.jp/projects/sat/gcom_w/index_e.html

- (3) GCOM/EORC site

<http://suzaku.eorc.jaxa.jp/GCOM/index.html>

- (4) GCOM-W1 Data Providing Service

<https://gcom-w1.jaxa.jp/auth.html>

- (5) “Aqua” Earth Observation Satellite

http://www.jaxa.jp/projects/sat/aqua/index_e.html

- (6) Earth Observation Research Center (EORC) website

<http://www.eorc.jaxa.jp/en/index.php>

- (7) AMSR/AMSR-E site (JAXA/EORC)

<http://sharaku.eorc.jaxa.jp/AMSR/index.html>

- (8) Data Distribution Service for AMSR/AMSR-E

<http://www.eorc.jaxa.jp/en/about/distribution/info/aqua.html>

■ Overseas

- (9) NASA website

<http://www.nasa.gov/>

- (10) Aqua website

<http://aqua.nasa.gov/>

- (11) AMSR-E website (NASA/MSFC)

<http://wwwghcc.msfc.nasa.gov/AMSR/>

- (12) HDF website

<http://www.hdfgroup.org/>

Appendix 2.3 Point of Contact

◆About this Data Users Handbook

GCOM-W1 Data Providing Service's Help Desk
Tsukuba Space Center, Japan Aerospace Exploration Agency,
2-1-1 Sengen, Tsukuba, Ibaraki, 305-8505
E-mail : Z-gw1help@jaxa.jp

◆About GCOM-W1Data

Please refer 5.2.4 (13) *Inquiries*.

Appendix 3 AMSR2 Product Format Documents

Appendix 3.1 AMSR2 product format specification

- (1) AMSR2 level 1 product format specification(SGC-120003)
- (2) AMSR2 Higher level product format specification(SGC-120005)