

**GCOM-W1 AMSR2 User Tool  
User Manual**

**Ver.5.0**

**2019.03**

Revision record

Rev.	Date	Page	Details of revision
Ver.1.0	2010.09	All	First Release
Ver.2.0	2013.01	P46-47	Added the description of HDF output
Ver.3.0	2013.03	All	<ul style="list-style-type: none"> <li>• Added the condition of Windows 7 on 1.4 Environment.</li> <li>• Added the explanation of install and uninstall.</li> <li>• Substituted AMSR2 fig.</li> </ul>
Ver.4.0	2015.03	<p>P12-15</p> <p>P28</p> <p>P33</p> <p>P34</p> <p>P37</p> <p>P44</p> <p>P110</p> <p>P137</p> <p>P138</p> <p>P139</p>	<p>Substituted install fig.</p> <p>Added the explanation of frequency selection.</p> <p>Added the explanation of frequency selection.</p> <p>Changed reference to 4.1.1.1</p> <p>Added the explanation of frequency selection.</p> <p>Added the explanation of frequency selection.</p> <p>Substituted Version Information fig.</p> <p>Added the Channel (L2) to parameter of Data display.</p> <p>Added the Channel (L2) to parameter of Animation.</p> <p>Added the Channel (L2) to parameter of HDF Output.</p>
Ver.4.1	2015.03	<p>P17,P25,</p> <p>P28,P29,</p> <p>P34-P39,</p> <p>P40-P47,</p> <p>P49,P50,</p> <p>P51,P52,</p> <p>P54,P55,</p> <p>P59,P60,</p> <p>P65,P66,</p> <p>P73,P85,</p> <p>P87,P88,</p> <p>P142</p>	Corrected errors.
Ver.5.0	2019.03	P11	Operating environment version correction.

Rev.	Date	Page	Details of revision
		P12-P15	Image replacement of installation screen.
		P111-P112	Substituted Version Information fig.

# Contents

<b>1. Introduction</b> .....	1
<b>1.1. Overview</b> .....	1
<b>1.2. References</b> .....	2
<b>1.3. Object data</b> .....	3
<b>1.4. Environment</b> .....	11
<b>1.5. Install</b> .....	12
<b>1.6. Uninstall</b> .....	16
<b>2. Configuration</b> .....	17
<b>3. Window Composition</b> .....	18
<b>4. How to operate</b> .....	21
<b>4.1. File Menu</b> .....	21
<b>4.1.1. Open/Animation</b> .....	22
<b>4.1.2. Save as Image</b> .....	48
<b>4.1.3. Save as KML (KMZ)</b> .....	49
<b>4.1.4. Save as Binary</b> .....	50
<b>4.1.5. Save as CSV</b> .....	50
<b>4.1.6. Copy to Clipboard</b> .....	52
<b>4.1.7. Save as HDF</b> .....	53
<b>4.1.8. Execution of batch processing</b> .....	54
<b>4.1.9. Quit</b> .....	54
<b>4.2. View Menu</b> .....	55
<b>4.2.1. Tool Bar</b> .....	56
<b>4.2.2. Status Bar</b> .....	67
<b>4.2.3. Zoom</b> .....	70
<b>4.2.4. Map Projection</b> .....	74
<b>4.2.5. Meta Data</b> .....	81
<b>4.2.6. Color Bar Position</b> .....	82
<b>4.2.7. ZOOM Mode</b> .....	83
<b>4.2.8. PAN Mode</b> .....	85
<b>4.2.9. SELECT Mode</b> .....	85
<b>4.2.10. Select Area</b> .....	86
<b>4.2.10. Batch Command History</b> .....	88
<b>4.3. Option Menu</b> .....	90
<b>4.3.1. Edit Color Bar Table</b> .....	91
<b>4.3.2. Edit Look Up Table</b> .....	95
<b>4.3.3. User Setting</b> .....	98
<b>4.3.4. Image Output option</b> .....	100

4.3.5. Map Layer.....	107
4.3.6. Position Error Correction.....	109
4.4. Help Menu.....	111
4.4.1. Help.....	111
4.4.2. Related link .....	112
4.4.3. Version Information.....	112
Appendix A File Format .....	113
Appendix A.1 Binary File Format .....	113
Appendix A.2 CSV File Format .....	116
Appendix A.3 KML File Format.....	119
Appendix A.4 KML File Format (The Timeline Function) .....	123
Appendix A.5 HDF format .....	126
Appendix A.6 Color Bar Table File Format .....	132
Appendix A.7 Look Up Table File Format .....	134
Appendix A.8 Batch File .....	136
Appendix A.9 Initial Parameter File Format.....	142
Appendix B Licenses .....	146
Appendix B.1 HDF4 .....	146
Appendix B.1 HDF5 .....	148
Appendix B.1 zlib .....	150

# 1. Introduction

This document describes the operation method of The GCOM User Tool.

## 1.1. Overview

The GCOM User Tool is a tool to project earth observation data (AMSR/AMSR-E/AMSR2) in the map. The earth observation data is offered by the Japan Aerospace Exploration Agency (JAXA). The functions of the This User Tool are shown in Table 1.1-1.

Table 1.1-1 GCOM User Tool functions

Function	Description
Data display	The observational data and latitude and longitude information are read from each product of AMSR/AMSR-E/AMSR2, and data is displayed on a screen by the map projection according to each product. Drag & drop operation is available for specifying the file to display.
Zoom In / Out Move	The arbitrary parts of the picture displayed on the map are zoomed in / out. Moreover, a picture can be moved by the mouse operation.
Data clip	The arbitrary area where the clip was done can be output to the file by the form supported by the format conversion function.
Format conversion	The data of the area specified by the product on the map is output to the file in the form of the following. ·Binary      ·CSV ·KML(KMZ)   ·Image (JPEG, TIFF, BMP, PNG) Moreover, this function is able to copy a displayed image to clipboard.
Animation	Each product of AMSR/AMSR-E/AMSR2 is read, and Animation file (AVI format/ KML(KMZ) format) is output.
Annotation information	The meta information stored in the product on the map is displayed. And the product information (channel, observation time range; only case of single channel) and the latitude and longitude information (and observation values) specified by mouse will be appeared at the frame under screen .
Help	The document and FAQ that describes the operation method of this user tool by the menu operation are displayed on a browser. Moreover, the information that relates to the earth observation data is displayed on a browser.

## 1.2. References

The format of each product of MSR/AMSR-E/AMSR2 has been described to the following document.

The following document is downloadable from the web site (<http://www.eorc.jaxa.jp/en/index.html>) .

- (1) AMSR Level 1 product format description (NEB-01040)
- (2) AMSR Level 2 format description (NDX-000154)
- (3) AMSR Level 2 Map format description (NDX-000152)
- (4) AMSR Level 3 format description (NDX-000155)
- (5) AMSR Level 1 format description (NEB-00011)
- (6) AMSR Level 2 format description (NDX-000272)
- (7) AMSR-E Level 2 Map format description (NDX-000273)
- (8) AMSR-E Level 3 product format description (NDX-000274)
- (9) AMSR2 Level 1 product format description (DSS02-XU05ASD-10-106)
- (10) AMSR2 Level 2,3 format description (DSS02-XU05ASD-10-107)

### **1.3. Object data**

The map projection that can be displayed is decided depending on the kind of the product of AMSR/AMSR-E/AMSR2. Moreover, the kind of logging and convertible format is also decided.

These relations are shown in Table 1.3-1.



Table 1.3-1 Correspondence between a product and a function (AMSR2)(1/4)

Level	Product		Data Type	Map projection(*1) (○=Available(◎:Default))				Output file format					Animation Format		
				EQR	PS	Ortho	MER	Binary	CSV	(Latitude/ Longitude) CSV(*2)	Image (*3)	HDF (*6)	KML/ KMZ (*4)	AVI	KML/K MZ (*5)
L1	1A		Scene(Half orbit)	◎	○	○	○	○	○	○	○	-	○	○	-
	1B		Scene(Half orbit)	◎	○	○	○	○	○	○	○	○	○	○	-
	1R		Scene(Half orbit)	◎	○	○	○	○	○	○	○	○	○	○	-
L2	Total Precipitable Water	TPW	Scene(Half orbit)	◎	○	○	○	○	○	○	○	○	○	○	-
	Cloud Liquid Water	CLW	Scene(Half orbit)	◎	○	○	○	○	○	○	○	○	○	○	-
	Precipitation	PRC	Scene(Half orbit)	◎	○	○	○	○	○	○	○	○	○	○	-
	Sea Surface Temperature	SST	Scene(Half orbit)	◎	○	○	○	○	○	○	○	○	○	○	-
	Sea Surface Wind speed	SSW	Scene(Half orbit)	◎	○	○	○	○	○	○	○	○	○	○	-
	Snow Depth	SND	Scene(Half orbit)	◎	○	○	○	○	○	○	○	○	○	○	-
	Sea Ice Concentration	SIC	Scene(Half orbit)	◎	○	○	○	○	○	○	○	○	○	○	-
	Soil moisture Content	SMC	Scene(Half orbit)	◎	○	○	○	○	○	○	○	○	○	○	-
L3 (Daily)	Brightness Temperature	TB	Global EQR	◎	-	-	-	○	○	-	○	-	○	○	○
			Northern	-	◎	-	-	○	○	-	○	-	-	○	-

Table 1.3-1 Correspondence between a product and a function (AMSR2)(2/4)

Level	Product		Data Type	Map projection(*1) (○=Available(◎:Default))				Output file format					Animation Format		
				EQR	PS	Ortho	MER	Binary	CSV	(Latitude/ Longitude) CSV(*2)	Image (*3)	HDF (*6)	KML/ KMZ (*4)	AVI	KML/K MZ (*5)
			Hemisphere PS												
			Southern Hemisphere PS	-	◎	-	-	○	○	-	○	-	-	○	-
	Total Precipitable Water	TPW	Global EQR	◎	-	-	-	○	○	-	○	-	○	○	○
	Cloud Liquid Water	CLW	Global EQR	◎	-	-	-	○	○	-	○	-	○	○	○
	Precipitation	PRC	Global EQR	◎	-	-	-	○	○	-	○	-	○	○	○
	Sea Surface Temperature	SST	Global EQR	◎	-	-	-	○	○	-	○	-	○	○	○
	Sea Surface Wind speed	SSW	Global EQR	◎	-	-	-	○	○	-	○	-	○	○	○
	Snow Depth	SND	Global EQR	◎	-	-	-	○	○	-	○	-	○	○	○
			Northern Hemisphere PS	-	◎	-	-	○	○	-	○	-	-	○	-
	Snow Depth	SIC	Northern Hemisphere PS	-	◎	-	-	○	○	-	○	-	-	○	-
			Southern Hemisphere PS	-	◎	-	-	○	○	-	○	-	-	○	-
	Soil moisture Content	SMC	Global EQR	◎	-	-	-	○	○	-	○	-	○	○	○

Table 1.3-1 Correspondence between a product and a function (AMSR2)(3/4)

Level	Product		Data Type	Map projection(*1) (○=Available(◎:Default))				Output file format						Animation Format	
				EQR	PS	Ortho	MER	Binary	CSV	(Latitude/ Longitude) CSV(*2)	Image (*3)	HDF (*6)	KML/ KMZ (*4)	AVI	KML/K MZ (*5)
L3 (Monthly)	Brightness Temperature	TB	Global EQR	◎	-	-	-	○	○	-	○	-	○	○	○
			Northern Hemisphere PS	-	◎	-	-	○	○	-	○	-	-	○	-
			Southern Hemisphere PS	-	◎	-	-	○	○	-	○	-	-	○	-
	Total Precipitable Water	TPW	Global EQR	◎	-	-	-	○	○	-	○	-	○	○	○
	Cloud Liquid Water	CLW	Global EQR	◎	-	-	-	○	○	-	○	-	○	○	○
	Precipitation	PRC	Global EQR	◎	-	-	-	○	○	-	○	-	○	○	○
	Sea Surface Temperature	SST	Global EQR	◎	-	-	-	○	○	-	○	-	○	○	○
	Sea Surface Wind speed	SSW	Global EQR	◎	-	-	-	○	○	-	○	-	○	○	○
	Snow Depth	SND	Global EQR	◎	-	-	-	○	○	-	○	-	○	○	○
			Northern Hemisphere PS	-	◎	-	-	○	○	-	○	-	-	○	-
	Snow Depth	SIC	Northern Hemisphere PS	-	◎	-	-	○	○	-	○	-	-	○	-
			Southern Hemisphere PS	-	◎	-	-	○	○	-	○	-	-	○	-

Table 1.3-1 Correspondence between a product and a function (AMSR2)(4/4)

Level	Product		Data Type	Map projection(*1) (○=Available(◎:Default))				Output file format						Animation Format	
				EQR	PS	Ortho	MER	Binary	CSV	(Latitude/ Longitude) CSV(*2)	Image (*3)	HDF (*6)	KML/ KMZ (*4)	AVI	KML/K MZ (*5)
	Soil moisture Content	SMC	Global EQR	◎	-	-	-	○	○	-	○	-	○	○	○

(\*1)EQR, PS, Ortho and MER mean Equi-Rectangular Map Projection, Polar Stereo projection, Ortho Projection and Mercator projection, respectively.

(\*2) The portion specified at the time of the displayed by EQR/MER is outputted.

(\*3) JPEG, TIFF, BMP, PNG

(\*4) When the data displayed EQR projection, it is possible to output KML/KMZ file.

(\*5) When the data displayed EQR projection, it is possible to output Time lined KML/KMZ file.

(\*6)The output range image is specified on the drawn map(EQR,MER,PN,PS projection).

Table 1.3-2 Correspondence between a product and a function (AMSR/AMSR-E)(1/3)

Level	Product		Data Type	Map projection (○=Available(◎:Default))				Output file format					Animation Format	
				EQR	PS	Ortho	MER	Bin (*1)	CSV (*1)	(Latitude/ Longitude) CSV(*2)	Image (*3)	KML/ KMZ (*4)	AVI	KML/ KMZ (*5)
L1	1A		Scene(Half orbit)	◎	○	○	○	○	○	○	○	○	○	○
	1B		Scene(Half orbit)	◎	○	○	○	○	○	○	○	○	○	○
	1B Map		EQR	◎	○	○	○	○	○	○	○	○	○	○
			MER	◎	○	○	○	○	○	○	○	○	○	○
1B Map		PS	◎	○	○	○	○	○	○	○	○	○	○	
		Water Vapor		WV	Scene(Half orbit)	◎	○	○	○	○	○	○	○	○
L2	Cloud Liquid Water		CLW	Scene(Half orbit)	◎	○	○	○	○	○	○	○	○	○
	Amount of Precipitation		AP	Scene(Half orbit)	◎	○	○	○	○	○	○	○	○	○
	Sea Surface Wind Speed		SSW	Scene(Half orbit)	◎	○	○	○	○	○	○	○	○	○
	Sea Surface Temperature		SST	Scene(Half orbit)	◎	○	○	○	○	○	○	○	○	○
	Snow Water Equivalence		SWE	Scene(Half orbit)	◎	○	○	○	○	○	○	○	○	○
	Ice Concentration		IC	Scene(Half orbit)	◎	○	○	○	○	○	○	○	○	○
	Soil Moisture		SM	Scene(Half orbit)	◎	○	○	○	○	○	○	○	○	○
	L2 Map	Water Vapor		WV	EQR	◎	○	○	○	○	○	○	○	○
MER					◎	○	○	○	○	○	○	○	○	○
PS					◎	○	○	○	○	○	○	○	○	○
Cloud Liquid Water		CLW	EQR	◎	○	○	○	○	○	○	○	○	○	
			MER	◎	○	○	○	○	○	○	○	○	○	
			PS	◎	○	○	○	○	○	○	○	○	○	

Table 1.3-2 Correspondence between a product and a function (AMSR/AMSR-E)(2/3)

Level	Product		Data Type	Map projection (○=Available(◎:Default))				Output file format					Animation Format		
				EQR	PS	Ortho	MER	Bin (*1)	CSV (*1)	(Latitude/Longitude) CSV(*2)	Image (*3)	KML/KMZ (*4)	AVI	KML/KMZ (*5)	
	Amount of Precipitation	AP	EQR	◎	○	○	○	○	○	○	○	○	○	○	○
			MER	◎	○	○	○	○	○	○	○	○	○	○	○
			PS	◎	○	○	○	○	○	○	○	○	○	○	○
	Sea Surface Wind	SSW	EQR	◎	○	○	○	○	○	○	○	○	○	○	○
			MER	◎	○	○	○	○	○	○	○	○	○	○	○
			PS	◎	○	○	○	○	○	○	○	○	○	○	○
	Sea Surface Temperature	SST	EQR	◎	○	○	○	○	○	○	○	○	○	○	○
			MER	◎	○	○	○	○	○	○	○	○	○	○	○
			PS	◎	○	○	○	○	○	○	○	○	○	○	○
	Snow Water Equivalence	SWE	EQR	◎	○	○	○	○	○	○	○	○	○	○	○
			MER	◎	○	○	○	○	○	○	○	○	○	○	○
			PS	◎	○	○	○	○	○	○	○	○	○	○	○
	Ice Concentration	IC	EQR	◎	○	○	○	○	○	○	○	○	○	○	○
			MER	◎	○	○	○	○	○	○	○	○	○	○	○
			PS	◎	○	○	○	○	○	○	○	○	○	○	○
Soil Moisture	SM	EQR	◎	○	○	○	○	○	○	○	○	○	○	○	
		MER	◎	○	○	○	○	○	○	○	○	○	○	○	
		PS	◎	○	○	○	○	○	○	○	○	○	○	○	
L3	brightness temperature	TB	Global EQR	◎				○(*6)	○(*6)		○	○	○	○	
			Northern Hemisphere PS		◎			○(*6)	○(*6)		○		○		
			Southern Hemisphere PS		◎			○(*6)	○(*6)		○		○		
	Water Vapor	WV	Global EQR	◎				○(*6)	○(*6)		○	○	○	○	
	Cloud Liquid	CLW	Global EQR	◎				○(*6)	○(*6)		○	○	○	○	

Table 1.3-2 Correspondence between a product and a function (AMSR/AMSR-E)(3/3)

Level	Product		Data Type	Map projection (○=Available(◎:Default))				Output file format					Animation Format	
				EQR	PS	Ortho	MER	Bin (*1)	CSV (*1)	(Latitude/Longitude) CSV(*2)	Image (*3)	KML/KMZ (*4)	AVI	KML/KMZ (*5)
	Water													
	precipitation	AP	Global EQR	◎				○(*6)	○(*6)		○	○	○	○
	Sea Surface Wind	SSW	Global EQR	◎				○(*6)	○(*6)		○	○	○	○
	Sea Surface Temperature	SST	Global EQR	◎				○(*6)	○(*6)		○	○	○	○
	Snow Water Equivalence	SWE	Global EQR	◎				○(*6)	○(*6)		○	○	○	○
			Northern Hemisphere PS		◎				○(*6)	○(*6)		○		○
	Ice Concentration	IC	Northern Hemisphere PS		◎			○(*6)	○(*6)		○		○	
			Southern Hemisphere PS		◎				○(*6)	○(*6)		○		○
	Soil Moisture	SM	Global EQR	◎				○(*6)	○(*6)		○	○	○	○

(\*1) When you want to output data to binary or csv file, you should select "Mesh mode" in the "resolution" menu.

(\*2) The portion specified at the time of the displayed by EQR/MER is outputted.

(\*3) JPEG, TIFF, BMP, PNG

(\*4) When the data displayed EQR projection, it is possible to output KML/KMZ file.

(\*5) When the data displayed EQR projection, it is possible to output Time lined KML/KMZ file.

(\*6) GCOM User Tool can not output specified area int this product file.

## 1.4. Environment

The required environment for the GCOM User Tool is shown in the Table 1.4-1. The required disk space for saving Earth observation data is not included.

Table 1.4-1 Environment

Items	Conditions
Processor	Pentium II CPU or more
Operating System	Windows 7(32bit), 10(32bit),
RAM	7 (32bit):1GB or more 10 (32bit):1GB or more
Hard Disk Space	100MB or more
Display Unit	1024 pixels by 768 lines, High Color (24 bits mode) or more
Others	Mouse or Pointing device PDF Viewer and Web Browser

The GCOM User Tool reads various information (observation data, latitude and longitude value, etc.) from HDF file, and stores it in the memory of PC. Please install this tool in PC equipped with an enough memory when you display big size data.



## 1.5. Install

Install the GCOM User Tool to use it. Following explanation shows how to install.

### ① Setup

Execute the Installer, [GCOM-W1UserToolInstaller.msi]. When you execute it, the screen is shown in the Fig 1.5-1.

In this case, click the [**Next**] button.

※ When you don't install the GCOM User Tool, click the [**Cancel**] button.

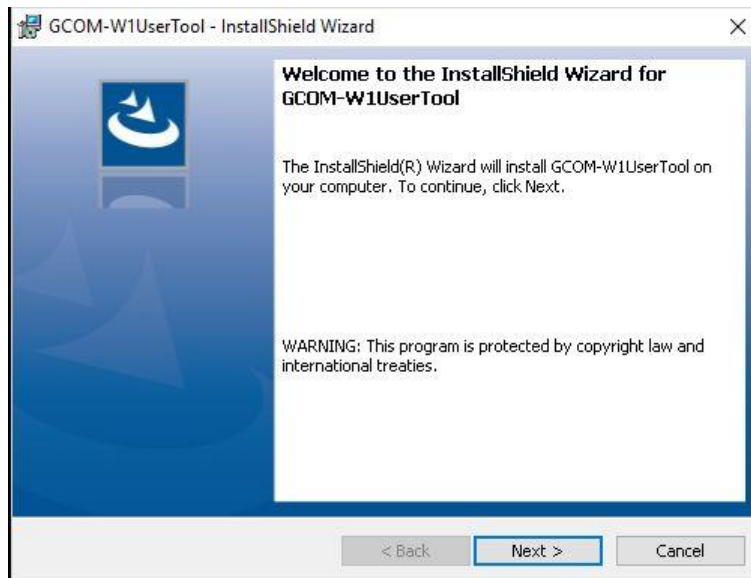

Fig 1.5-1 Setup Wizard

### ② Select the Installation Folder

Determine the destination of installing the GCOM User Tool, and click the [**Next**] button.

The screen of [Select Installation Folder] is shown as the Fig 1.5-2.

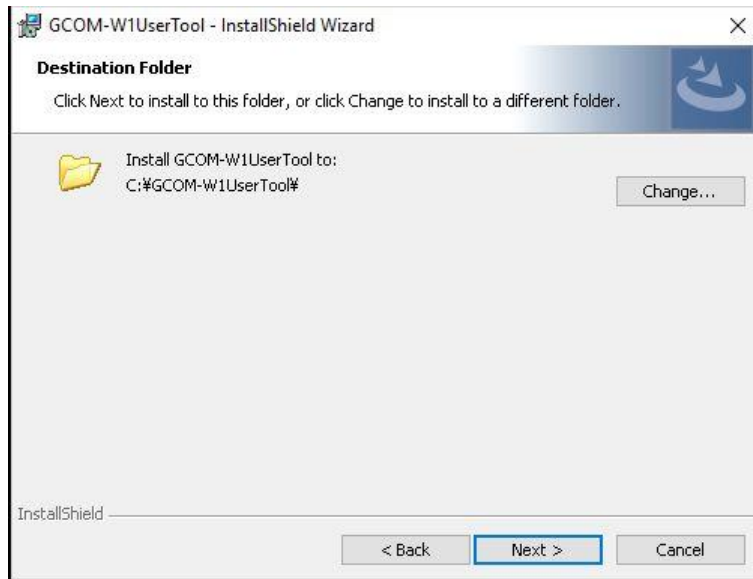

Fig 1.5-2 Select Installation Folder

### ③ Confirm Installation

Confirm the installation is ready. When you start installing, click the **[Install]** button.

When you change the configuration, click the **[Back]** button.

The screen of [Confirm Installation] is shown as the Fig 1.5-3.

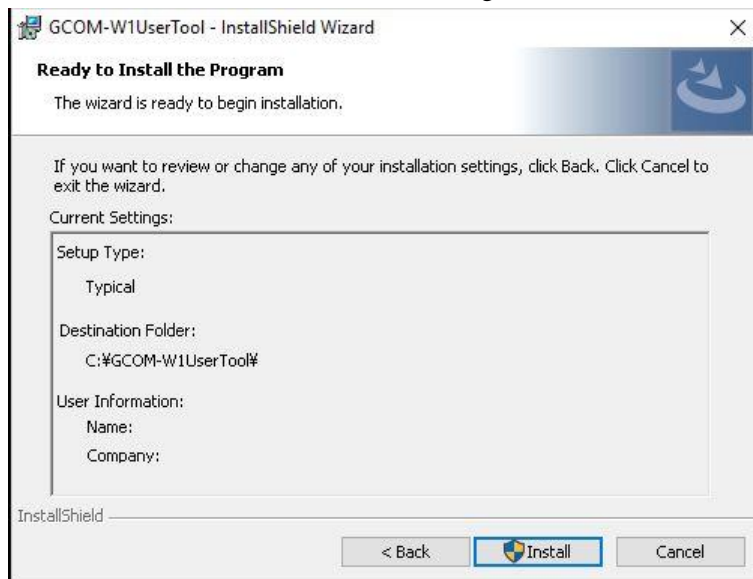

Fig 1.5-3 Confirm Installation

④ **Installing GCOM-W1UserTool**

The screen, the middle of installing is shown as the Fig 1.5-4. When you stop the installation, click the [Cancel] button.

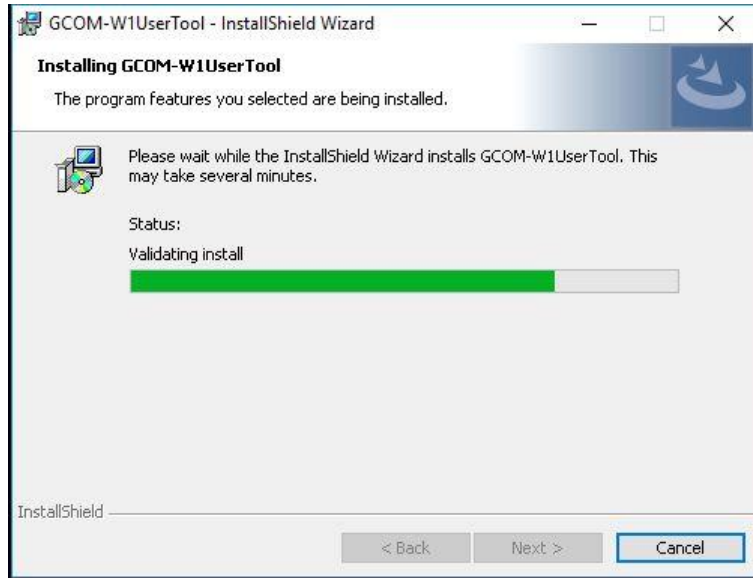

Fig 1.5-4 Installing GCOM-W1UserTool

⑤ **Installation Complete**

When installation of the GCOM User Tool is finished, the screen of [Installation Complete] is shown as the Fig 1.5-5.

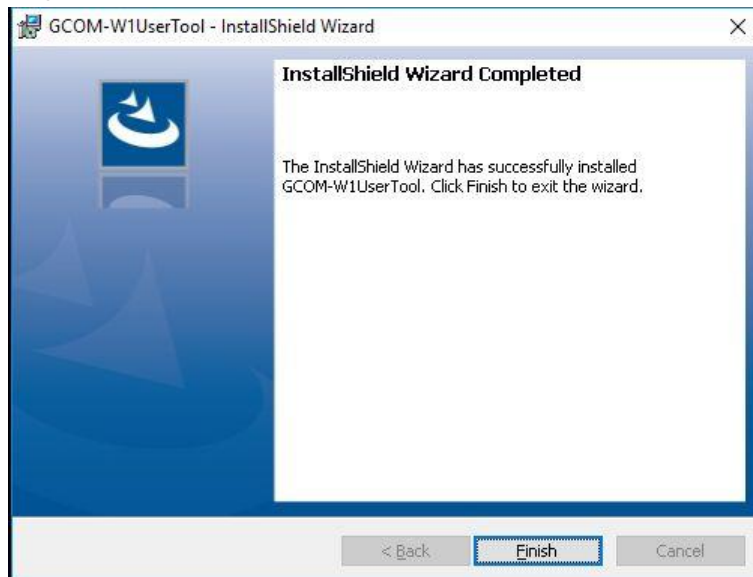

Fig 1.5-5 Installation Complete

⑥ **Confirmation after the installation**

When you confirm the installed products are shown in the start menu, the installation is finished.

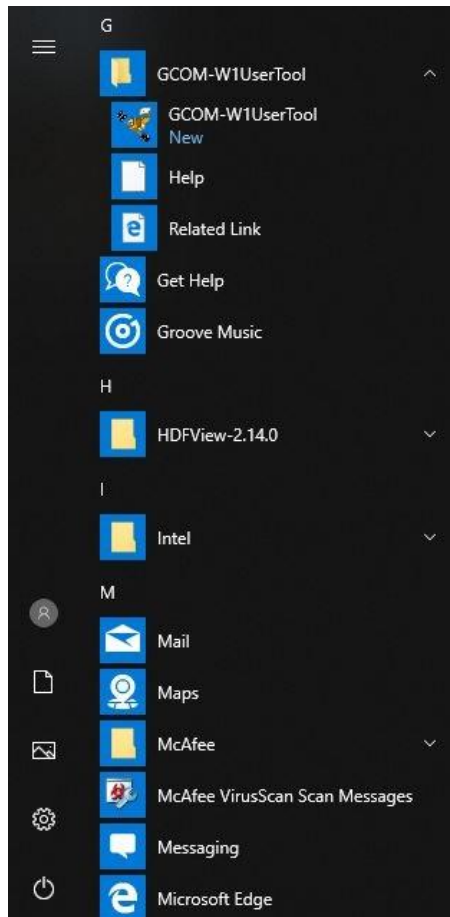

Fig 1.5-6 Start Menu

## 1.6. Uninstall

Following explanation shows how to uninstall the GCOM User Tool.

- ① Open the Control Panel, and select the Delete Programs.
- ② Choose the GCOM User Tool, and click the [**Delete**] or [**Uninstall**] button.
- ③ When the message box to confirm uninstall is displayed, click the [**Delete**] or [**Uninstall**] button.

## 2. Configuration

Before the GCOM User Tool is started, it is necessary to set the configuration.

The parameter (GCOM User Tool.ini) file in the installation folder is set up using the text editor of Windows system. Two kinds of information shown below are stored in the parameter file. Refer to "Initial Parameter File Format " (Appendix A.8) for more detail information.

(1) Folder definition Information

The folder which this user tool refers to is defined.

(2) User definition Information

Information (Data Display /Save as Binary /Save as CSV) peculiar to a user is defined.

This information can be set up using a [**User Setting Dialog**] besides the method of editing the parameter file directly. Please refer to [**4.3.3. User Setting**] about the operation of a [**User Setting Dialog**].

### **3. Window Composition**

The GCOM User Tool is composed of the window called from the main window and the menu. The window compositions and details are shown in the Table 3-1.

Table 3-1 Window detail(1/2)

No.	Window	Conditions
1.	Main Window	Window where map of data is displayed. PAN Mode, SELECT Mode Zoom In/Zoom Out of an image is specified.
2.	File Open Dialog (AMSR2/AMSR/AMSR-E)	This dialog where AMSR2/AMSR/AMSR-E data input are done. When data is input, the input product specification and Channel /color table/look-up table is specified.
3.	Output HDF File Open Dialog	This dialog is used to output the HDF file product. The HDF file is stored the image that is cut off part of the whole image.
4.	Create Animation Dialog (AMSR2/AMSR/AMSR-E)	This dialog is specified the AMSR2/AMSR/AMSR-E product used for the animation creating, and is specified Channel /color table.
5.	Animation Output Setting Dialog	This dialog changes Various settings of title display / background display color etc in the animation output.
6.	Display map & products Window	Window where the product data is projected in the map.
7.	User Setting Dialog	This dialog sets up initial information on this user tool.
8.	Image Output Setting Dialog	This dialog sets up the layout of saving a picture.
9.	A Narrow Line Dialog	This dialog sets indication color of coastline and latitude and longitude lines. Display color setting/ Thickness of line/ Interval in Longitude/latitude is selected.
10.	Map File Mode Dialog	This dialog sets up a map file.
11.	Edit Color Bar Table Dialog	This dialog sets up a color bar table and makes newly.
12.	Edit Look Up Table Dialog	This dialog sets up a look up table, and makes newly.
13.	Select Area Dialog	This dialog inputs the latitude and longitude of the upper left and the lower right, and specifies a domain.
14.	Meta Information Dialog	This dialog displays the core meta data of the picture.
15.	Version Information Window	This window displays the version information and copyright holder of this user tool.
16.	Help Window	Operation explanation of this user tool is displayed on a browser
17.	Related Information Window	Operation explanation of this user tool is displayed on a browser
18.	Batch File Selection Window	Batch File is selected on this window. The command in the file is analyzed when "Opening (O)" button is clicked after the file selected. And batch-process is done.
19.	Batch Command History Window	Window where operation that user did is memorized as



Table 3-1 Window detail(2/2)

No.	Window	Conditions
		command and displayed. However, the processing history of the function that the batch processing doesn't support it is not displayed.

## 4. How to operate

Refer to the explanation of the file menu for the operation of the GCOM User Tool.

### 4.1. File Menu

There are eight subsidiary menus in a file menu.

- (1) Open
- (2) Animation
- (3) Save as Image
- (4) Save as KML (KMZ)
- (5) Save as Binary
- (6) Save as CSV
- (7) Copy to Clipboard
- (8) Save as HDF
- (9) Execution of batch processing
- (10) Quit

File menus are shown in Fig. 4.1-1, and each menu is explained henceforth.

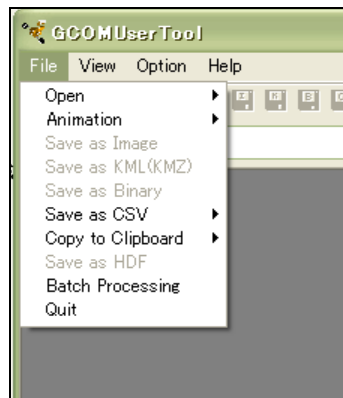

Fig. 4.1-1 File Menu Pull Down

#### 4.1.1. Open/Animation

On this user tool, there are two methods of selecting the product file to display, as follows:

- (1) Using File Open Dialog/Create Animation Dialog.
- (2) Dragging product file(s) and dropping onto the shortcut icon.

The outline is explained as follows.

##### [Using File Open Dialog/Create Animation Dialog.]

There are two subsidiary menus in a file open menu.

- (1) Open AMSR2/ Products
- (2) Open AMSR/AMSR-E Products

Moreover, there are two subsidiary menus in an animation menu.

- (1) AMSR2 Product
- (2) AMSR/AMSR-E Product

Subsidiary menus of [Open] menu are shown in Fig. 4.1.1-1, and subsidiary menus of [Animation] are shown in Fig. 4.1.1-2. The product file to display is selected by using [File Open] or [Create Animation] dialog that displayed to select these subsidiary menus. Each subsidiary menu is explained below.

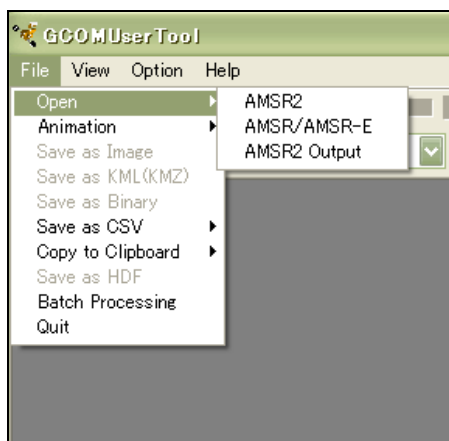

Fig. 4.1.1-1 [Open] subsidiary menu

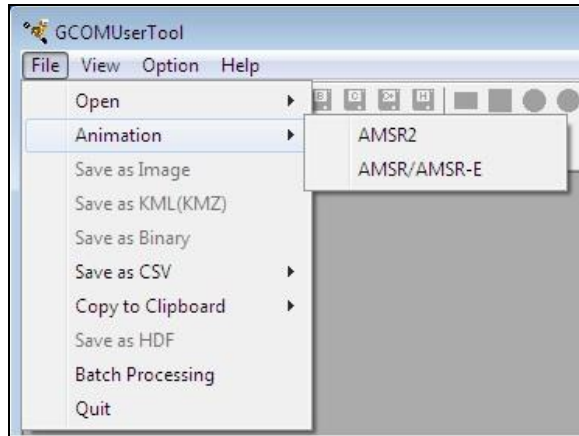

Fig. 4.1.1-2 [Animation] subsidiary menu

**[Dragging product file(s) and dropping onto the shortcut icon.]**

It is possible to specify the product file(s) to be drawn by dragging it and dropping onto the shortcut icon of this user tool (Fig. 4.1.1-3). After installing this user tool, the shortcut icon is appeared on the desktop. This function is available for displaying. Fig. 4.1.1-3

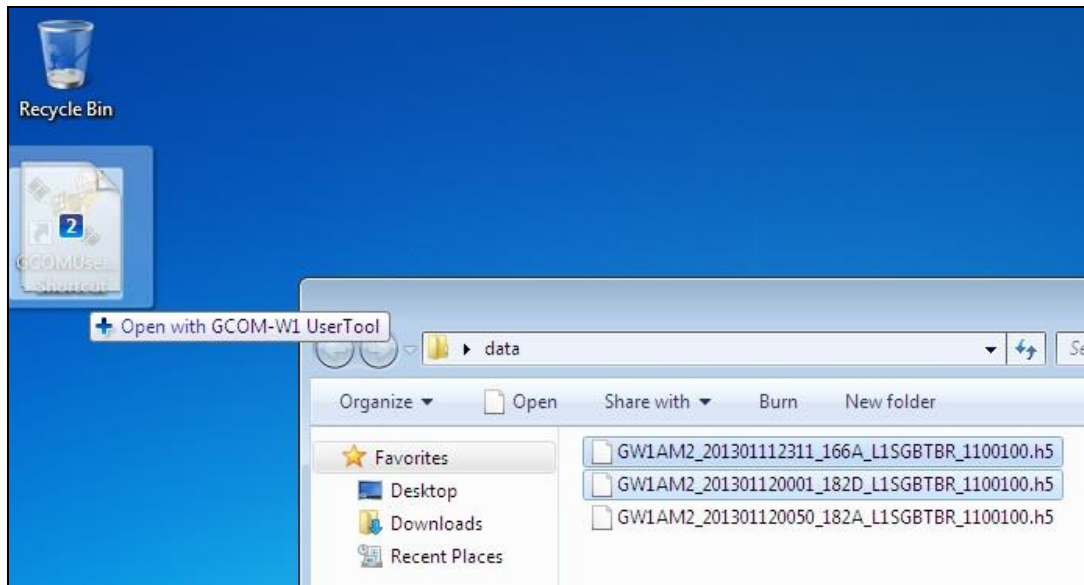

Fig. 4.1.1-3 Drag & drop

After this operation, [Display map & products Window] and [File Open dialog] according to the specified file will appear (Fig.4.1.1-4).

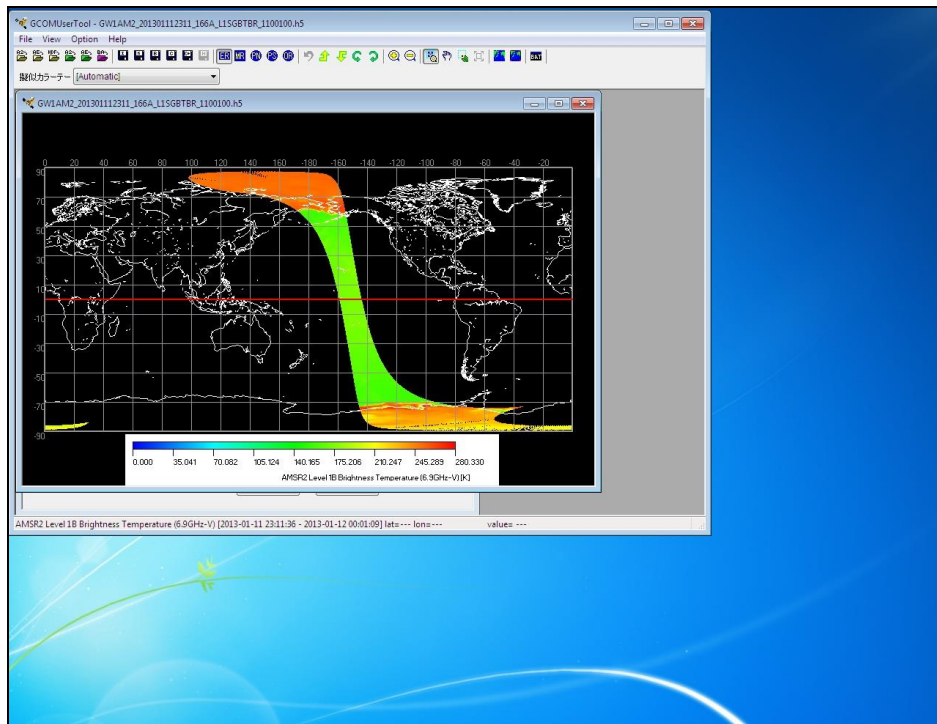

Fig. 4.1.1-4 An example of image display by drag & drop operation to short cut icon

When you specify files of the same product levels at the same time, all specified files aren't displayed in the following cases.

- If you specify files of Level3, only one file of specified files is displayed.
- If number of the files specified exceeds maximum number, [File Open Dialog] will be only displayed.

When you drag and drop multiple product levels at the same time, displaying follows the following priority rules.

If you specify multiple sensors, displaying priority is AMSR2/AMSR/AMSR-E, if you specify multiple levels, the files of lower level are preferentially displayed.

#### 4.1.1.1. Open AMSR2 Products

When the [Open AMSR2 Products] subsidiary menu is selected, [File Open Dialog (AMSR2)] is displayed, and an AMSR and/or AMSR-E product can be read. How to read an AMSR/AMSR-E product is explained. [File Open Dialog (AMSR2)] layout is shown in Fig.4.1.1.1-1.

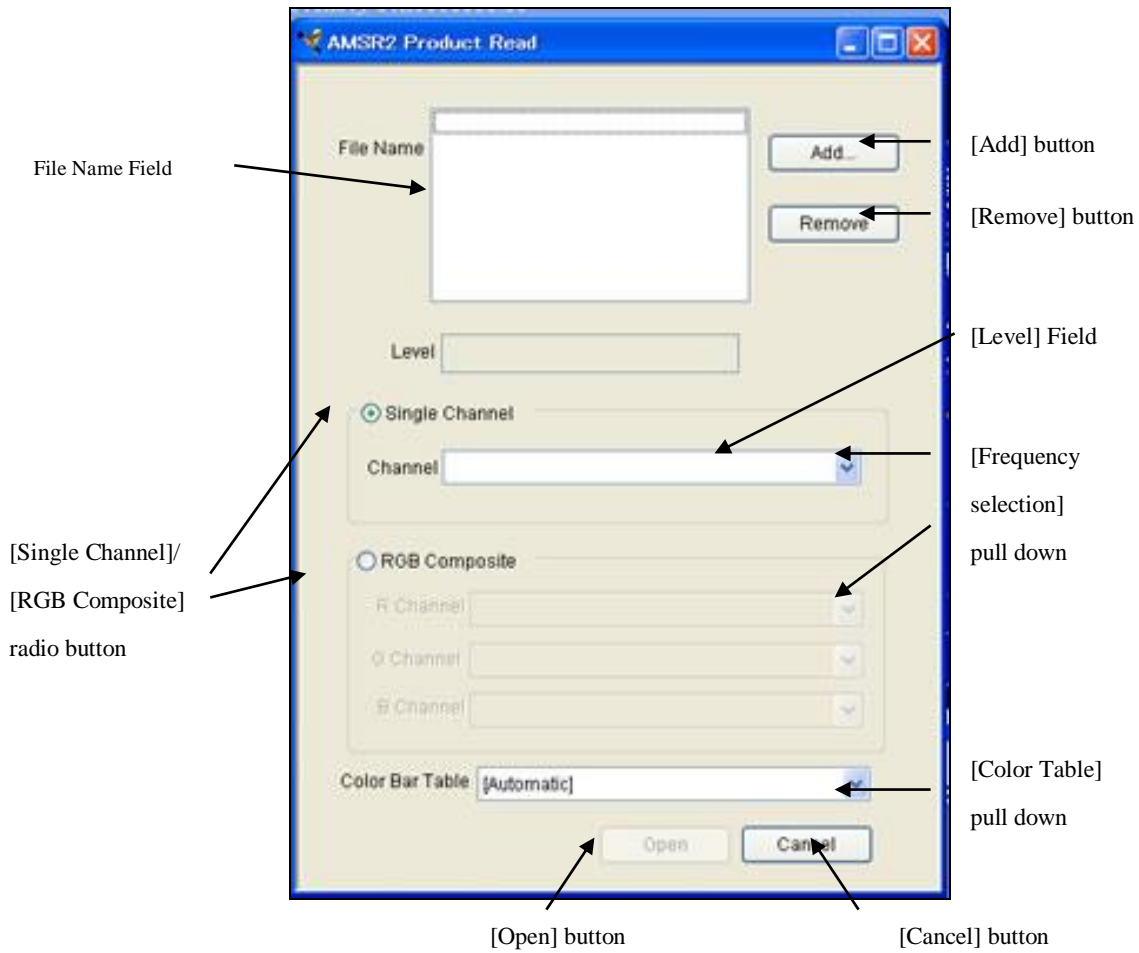

Fig. 4.1.1.1-1 File Open Dialog (AMSR2)

■ File Name Field

In this Field, the specified file names of AMSR2 products are displayed. It is possible to specify files by using [Add] button or drag & drop operation (Fig. 4.1.1.1-2).

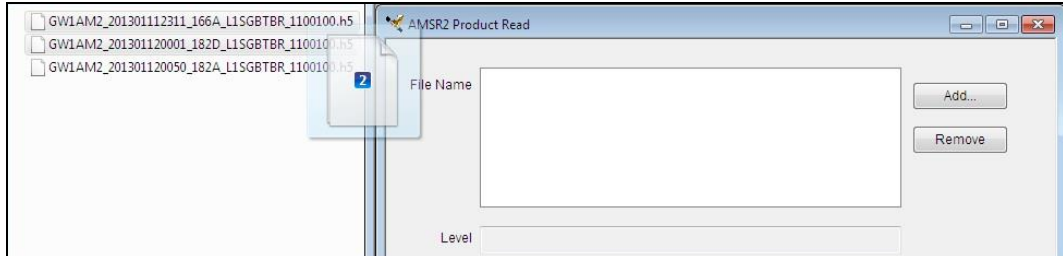

Fig. 4.1.1.1-2 Drag & drop operation

You must select same product level of AMSR2 product. (Case of Level 3, you must also select same projection.) The product level will be displayed on [Level] field.

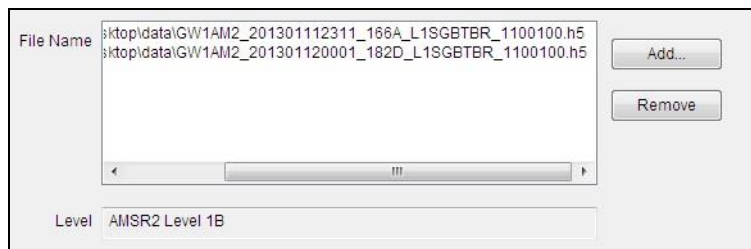

Fig. 4.1.1.1-3 Result of addition to File Name Field

The number of files that can be specified for this list is decided depending on the number of maximum files set in the configuration setting.

■ [Add] button

- ① [Add] button is clicked.
- ② [Open] dialog' that Windows offers is displayed
- ③ The file of the AMSR2 product added to [File Name Field] can be selected.

■ [Remove] button

- ① Select to delete a file from files list.
- ② [Remove] button is clicked.
- ③ It is possible to delete a file from files list in [Open AMSR2 Products] by selecting file name

■ [Single Channel] / [RGB Composite] radio button

- ① Select either Single Channel mode or RGB Composite Image mode.

② The channel is specified from the data display selection pull-down.

\*) When you input Level 2/ Level 2 Map product, you cannot select Channel.

\*) When you input Level 3 product, you select a file instead of channel on the pull down list

In the state of the **[Single Channel]** / **[RGB Composite]** radio button, change the title of a **[Color Bar Table]**.

#### **[Single Channel]**

You shall select one of Color Bar Table from this **[Color Bar Table]** pull down list for the Single Channel mode.

All files of extension "clt" stored in "AMSR2" folder in the color table folder are shown in this pull down list. You can select "[Automatic]" function that automatically adjusts the maximum/minimum value and 9 color palettes.

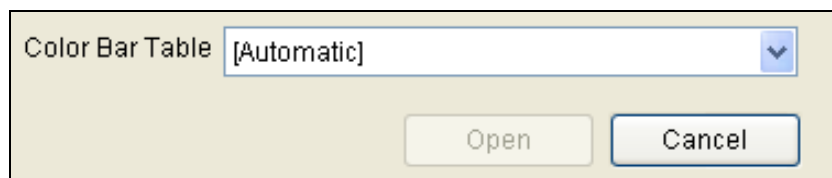

Fig. 4.1.1.1-4 [Color Bar Table] pull down



### [RGB Composite]

The [Color Table] title displays as a [Look Up Table].

You shall select one of Look Up Table from this [Look Up Table] pull down list for the RGB Composite Image mode.

All files of extension "lut" stored in "AMSR2" folder in look-up table folder are shown in this pull down list. You can select "[Automatic]" function that automatically makes the relation between the maximum/minimum count value of each RGB channel and the observation value be corresponding.

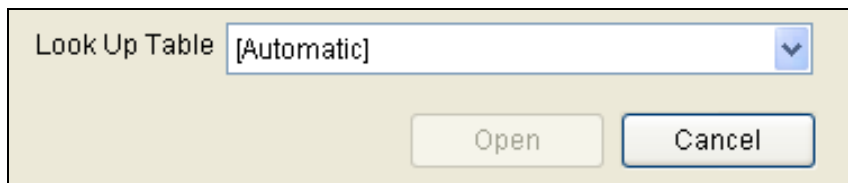

Fig. 4.1.1.1-5 [Look Up Table] pull down

### ■ [Frequency selection] pull down

Select a channel.

If the product is level 2, you can select up to second layer of physical amount.

However, if you select the second layer even though the product has only one layer, an error message will be displayed.

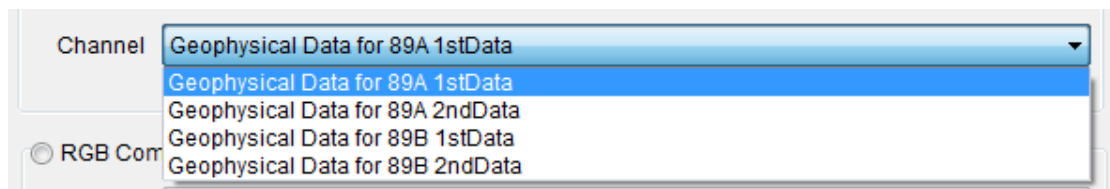

Fig. 4.1.1.1-6 [Frequency selection] pull down (High resolution)

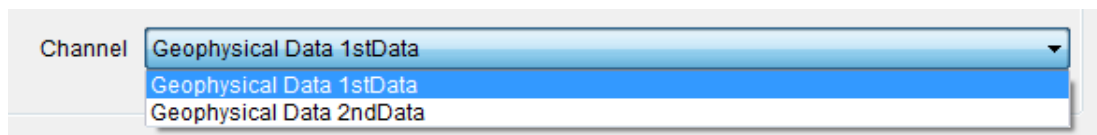

Fig. 4.1.1.1-7 [Frequency selection] pull down (Low resolution)

■ **[Open]** button

- ① **[Open]** button is clicked.
- ② Display the map and products Window will be displayed on the new window[Fig. 4.1.1.1-8].

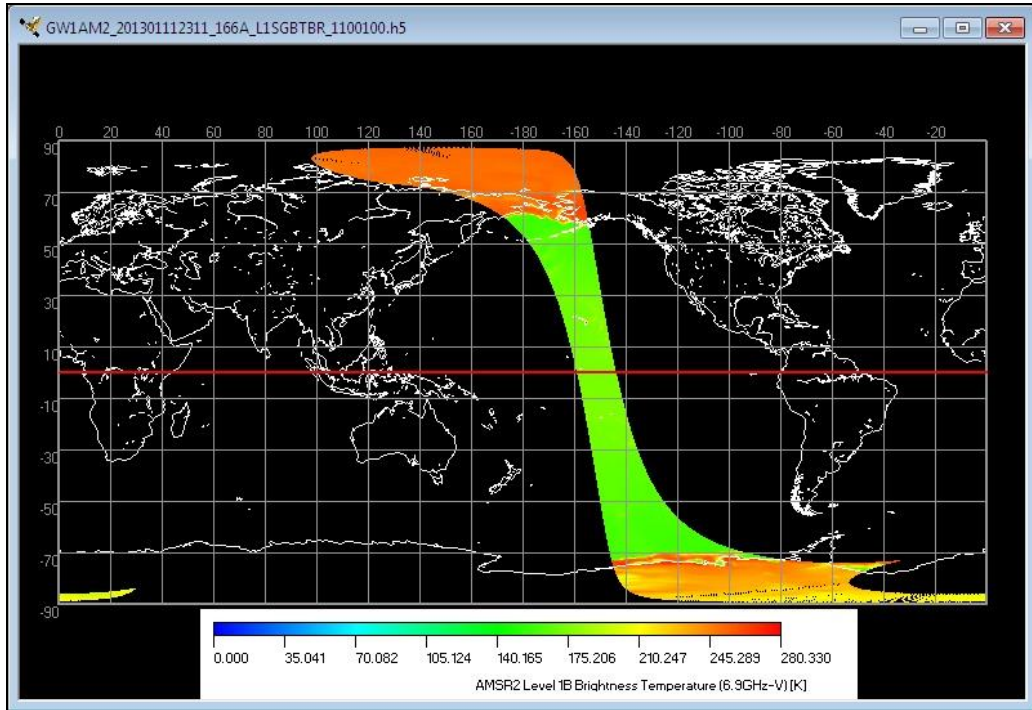

Fig. 4.1.1.1-8 Image Window

■ [Cancel] button

- ① [Cancel] button is clicked.
- ② All setting shown in the dialog is canceled and the dialog is closed.

**4.1.1.2. Open AMSR/AMSR-E Products**

When this [Open AMSR/AMSR-E Products] subsidiary menu is selected, [File Open Dialog (AMSR/AMSR-E)] is displayed, and a AMSR/AMSR-E product can be read. How to read a AMSR/AMSR-E product is explained. [File Open Dialog (AMSR/AMSR-E)] layout is shown in Fig. 4.1.1.2-1.

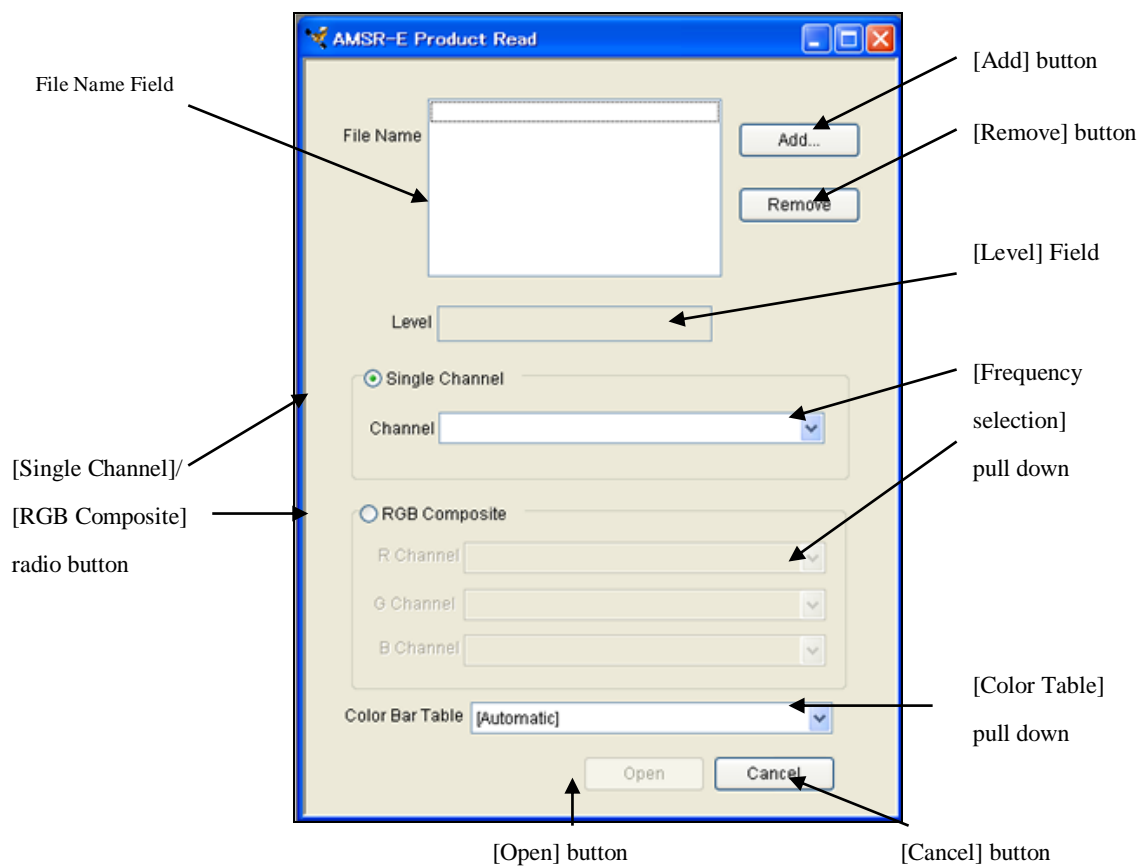

Fig. 4.1.1.2-1 File Open Dialog (AMSR/AMSR-E)

■ File Name Field

- ① In this field, the specified file name of AMSR/AMSR-E product is displayed.
- ② It is possible to specify files by using [Add] button or drag & drop operation (Please refer to 4.1.1.1).

Please specify only the AMSR/AMSR-E product for this field.

The number of files that can be specified for this list is decided depending on the number of maximum files set in the configuration setting.

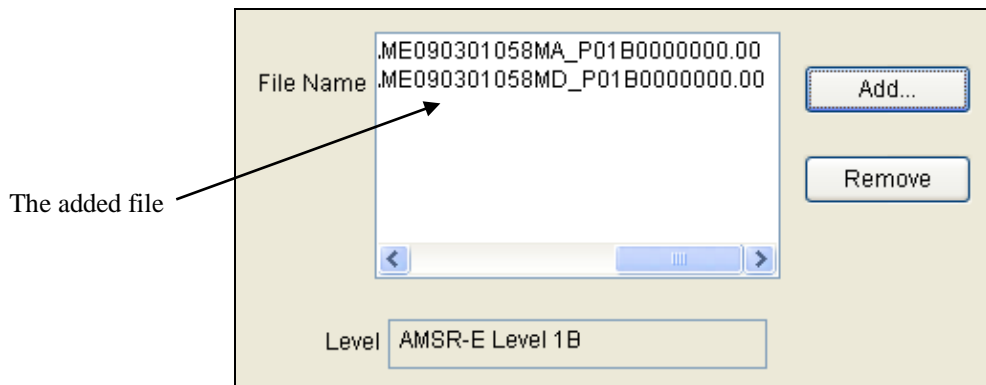

Fig. 4.1.1.2-2 Result of addition to File Name Field

■ [Add] button

- ① [Add] button is clicked.
- ② [Open] dialog' that Windows offers is displayed
- ③ The file of the AMSR/AMSR-E product added to [File Name Field] can be selected.

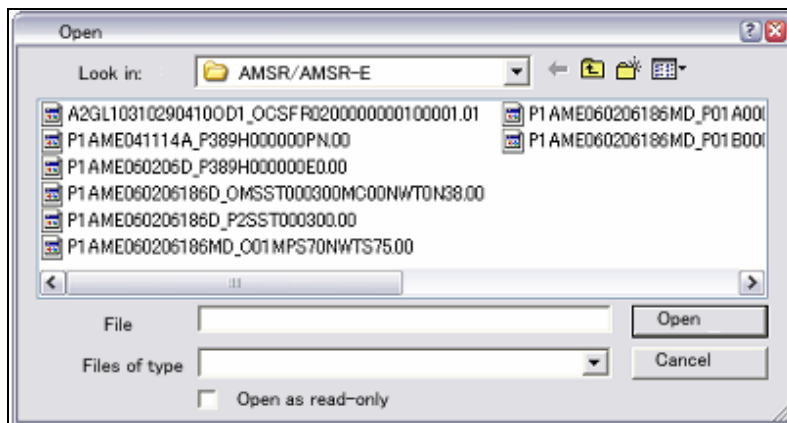

Fig. 4.1.1.2-3 File Select Dialog

■ **[Remove]** button

- ① Select to delete a file from files list.
- ② **[Remove]** button is clicked.
- ③ It is possible to delete a file from files list in **[Open AMSR/AMSR-E Products]** by selecting file name

■ **[Single Channel]** / **[RGB Composite]** radio button

- ① Select either Single Channel mode or RGB Composite Image mode.
- ② The channel is specified from the data display selection pull-down.

In the state of the **[Single Channel]** / **[RGB Composite]** radio button, change the title of a **[Color Bar Table]**.

**[Single Channel]**

The **[Color Table]** title displays as a **[Color Bar Table]**.

You shall select one of Color Bar Table from this **[Color Bar Table]** pull down list for the Single Channel mode.

All files of extension "clt" stored in "AMSR/AMSR-E " folder in the color table folder are shown in this pull down list. You can select "[Automatic]"function that automatically adjusts the maximum/minimum value and color 9 palettes.

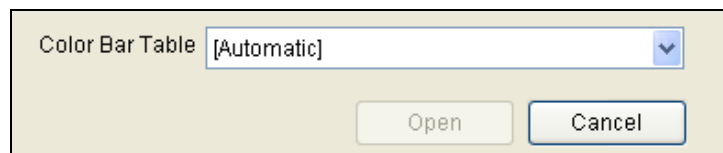

Fig. 4.1.1.2-4 **[Color Bar Table]** pull down

**[RGB Composite]**

The **[Color Table]** title displays as a **[Look Up Table]**.

You shall select one of Look Up Table from this **[Look Up Table]** pull down list for the RGB Composite Image mode.

All files of extension "lut" stored in "AMSR/AMSR-E" folder in look-up table folder are shown in this pull down list. You can select "[Automatic]"function that automatically makes the relation between the maximum/minimum count value of each RGB channel and the product value be corresponding.

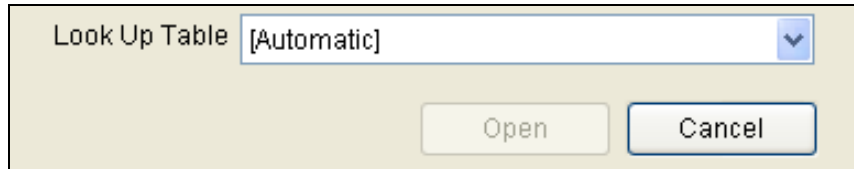

Fig. 4.1.1.2-5 [Look UpTable] pull down

■ [Frequency selection] pull down

Select a channel.

■ [Open] button

- ① [Open] button is clicked.
- ② Display map & products Window will be displayed on the new window[Fig. 4.1.1.2-6].

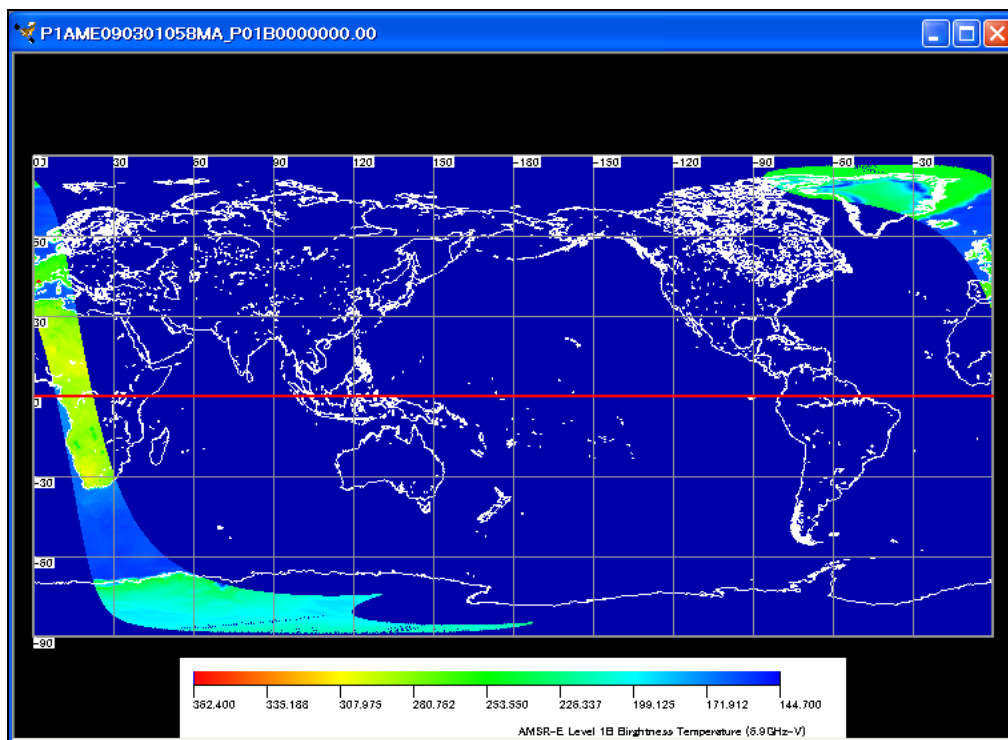

Fig. 4.1.1.2-6 Image Window

■ [Cancel] button

- ① [Cancel] button is clicked.
- ② All setting shown in the dialog is canceled and the dialog is closed.

### 4.1.1.3. Open AMSR2 Products with HDF output mode

When this [Open AMSR2 Products with HDF output mode] subsidiary menu is selected, [File Open Dialog (AMSR2 HDF Output)] is displayed, and a AMSR2 product can be read. How to read a AMSR2 product is explained. [File Open Dialog (AMSR2 HDF Output)] layout is shown in Fig. 4.1.1.3-1.

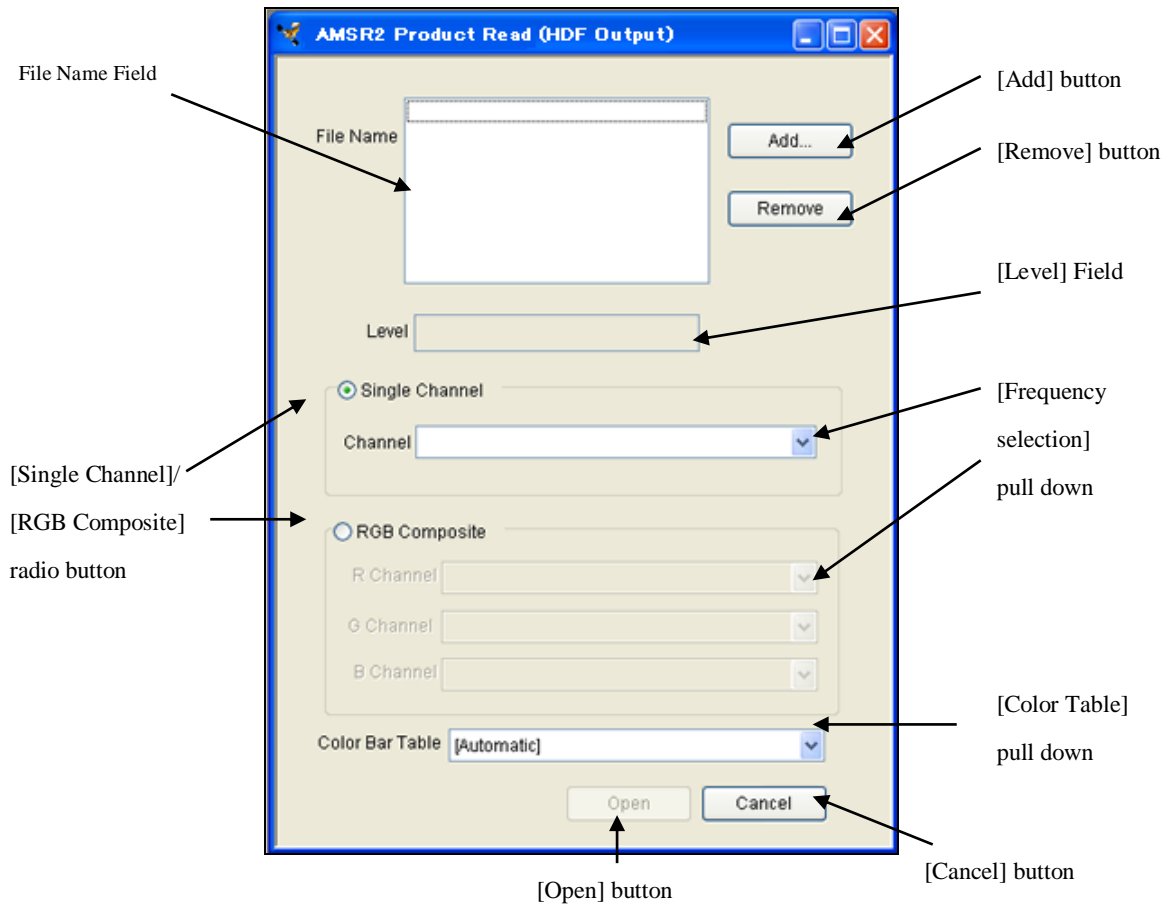

Fig. 4.1.1.3-1 File Open Dialog (AMSR2 HDF output)

Please refer to the [4.1.1.1. Open AMSR2 Products] to use buttons on this Dialog.

#### 4.1.1.4. Make AMSR2 Product Animation

If the [Make AMSR2 Animation] subsidiary menu is chosen, [Make AMSR2 Product Animation Dialog] is displayed, and the animation file of the AMSR2 product can be created.

How to create the animation file is explained. [Make AMSR2 Product Animation] layout is shown in Fig. 4.1.1.4-1.

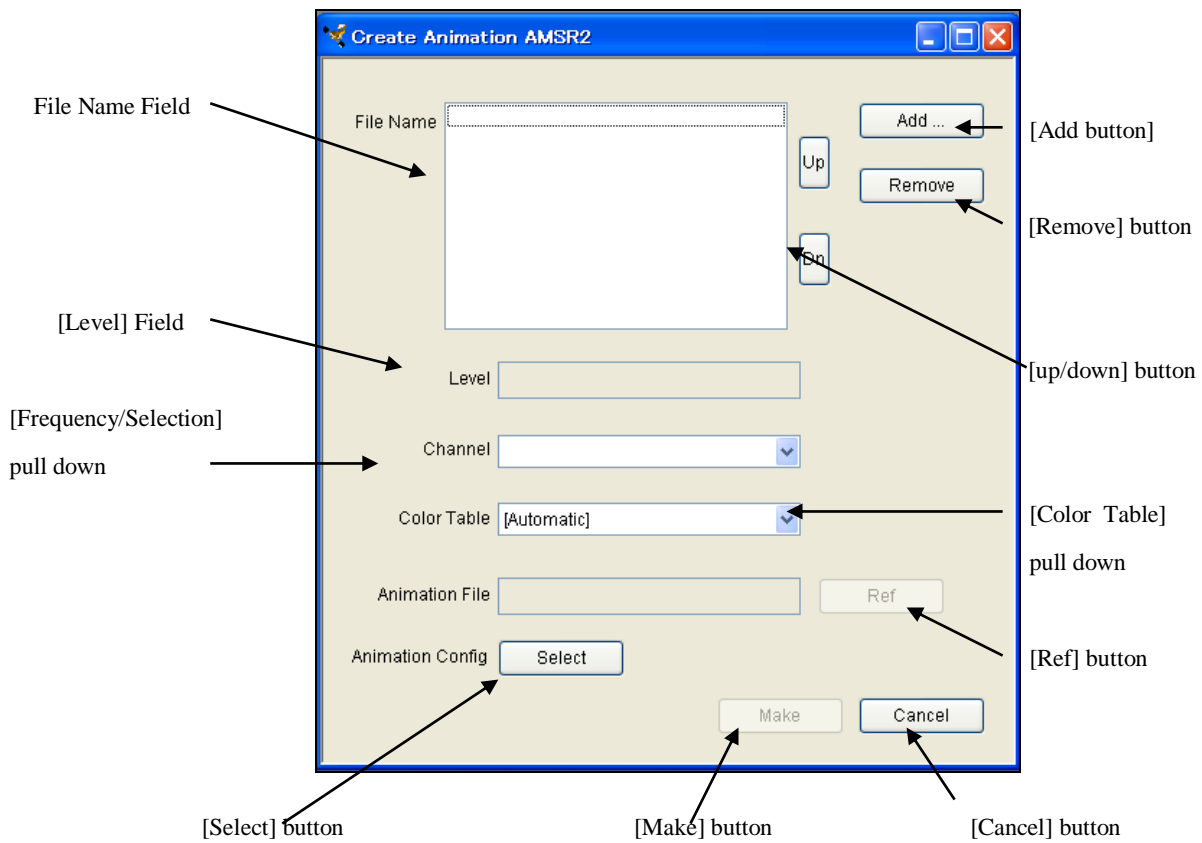

Fig. 4.1.1.4-1 Make AMSR2 Product Animation Dialog



■ File Name Field

- ① In this field, the specified file name of AMSR2 product is displayed.
- ② It is possible to specify files by using [Add] button or drag & drop operation  
(Please refer to 4.1.1.4-2).

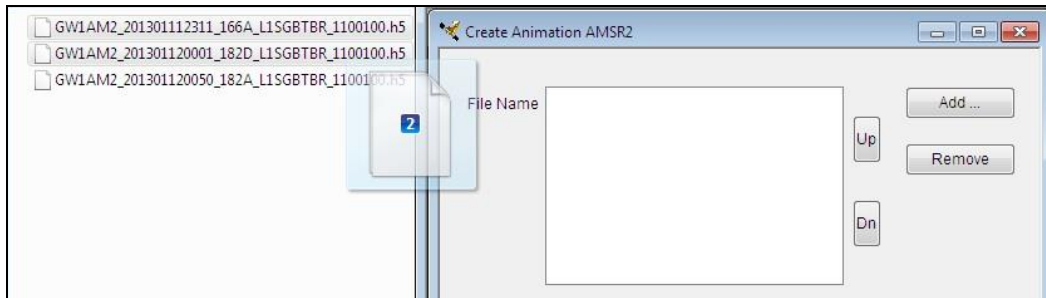

Fig. 4.1.1.4-2 Drag & drop operation

You must select same product level of files. (Case of Level 3, you must also select same projection.) The product level will be displayed on [Level] field.

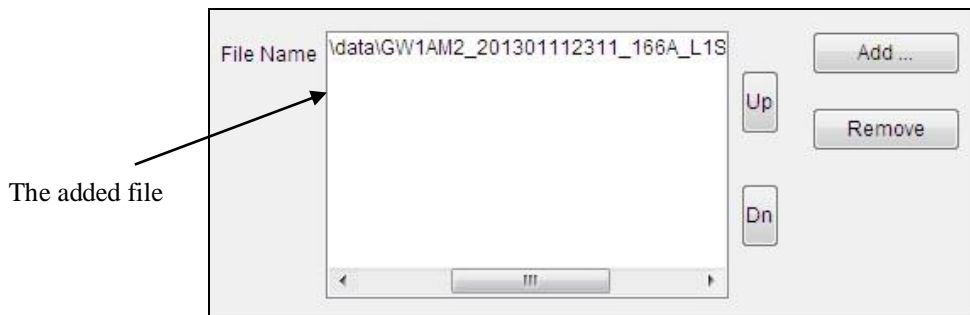

Fig. 4.1.1.4-3 Result of addition to File Name Field

The added file displayed on a [File Name Field]. The number of files that can be specified for this list is decided depending on the number of maximum files set in the configuration setting.

■ **[Add]** button

- ① **[Add]** button is clicked.
- ② **[Open]** dialog' that Windows offers is displayed
- ④ The file of the AMSR2 product added to [File Name Field] can be selected

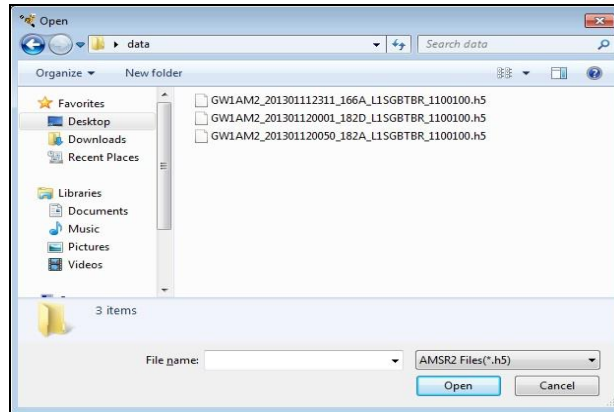

Fig. 4.1.1.4-4File Select Dialog

■ **[Remove]** button

- ① Select file that delete from file name list.
- ② **[Remove]** button is clicked.
- ③ It is possible to delete a file from file name list in **[Make AMSR2 Product Animation]** by selecting file name

■ **[up/down]** button

- ① Select file that changes the order from file name list.
- ② **[up/down]** button is clicked.
- ③ The order of filing "file name list" can be changed.

■ **[Frequency selection]** pull down

Select a channel.

If the product is level 2, you can select up to second layer of physical amount.

However, if you select the second layer even though the product has only one layer, an error message will be displayed.

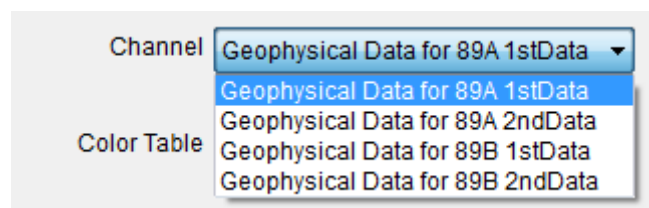

Fig. 4.1.1.4-5 [Frequency selection] pull down (High resolution)

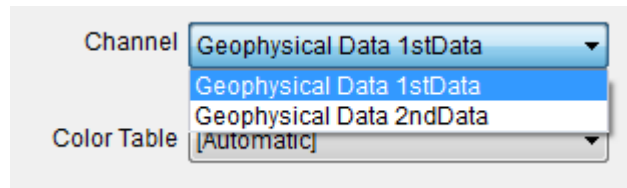

Fig. 4.1.1.4-6 [Frequency selection] pull down (Low resolution)

■ [Color Table] pull down

- ① The [Color Table] title to display from this pull-down can be selected.

■ [Select] button

- ① [Select] button is clicked
- ② [Animation Output Setting Dialog] is displayed.

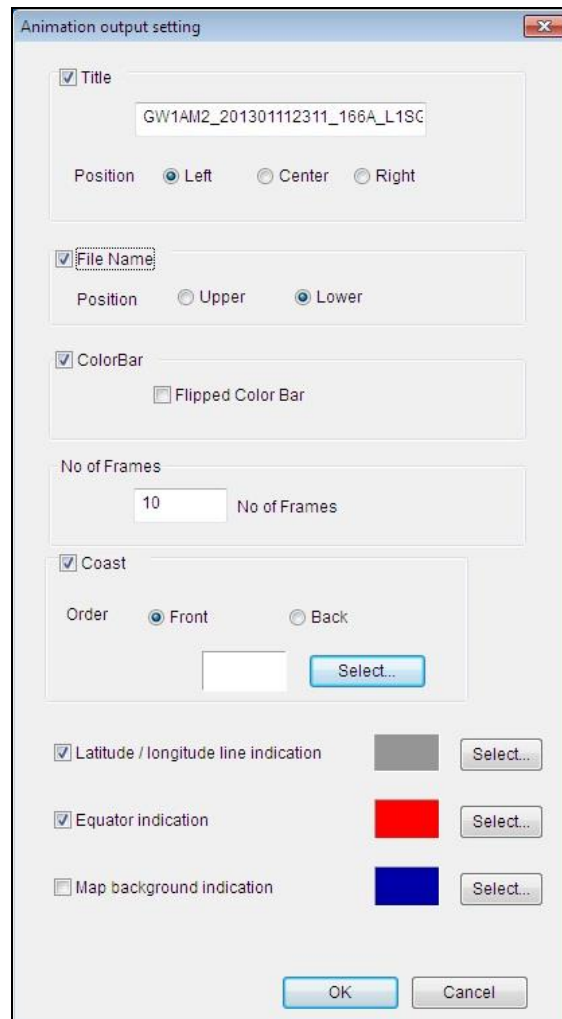

Fig. 4.1.1.4-7 [Animation Output Option] dialog

If you want to display [Title], [Color Bar], [File Name], [Coast], and [Latitude and longitude]

information, please mark each check box.

Moreover, color of each line, display position of [Title] and [File Name], and the order of displaying [Coast] can be specified. The display position of [Title] and [File Name] are specified from the following two kinds.

Additionally, please refer to "Image Output option" (Chapter 4.3.4) and "Map Layer" (Chapter 4.3.5) for more detail information.

[Upper]

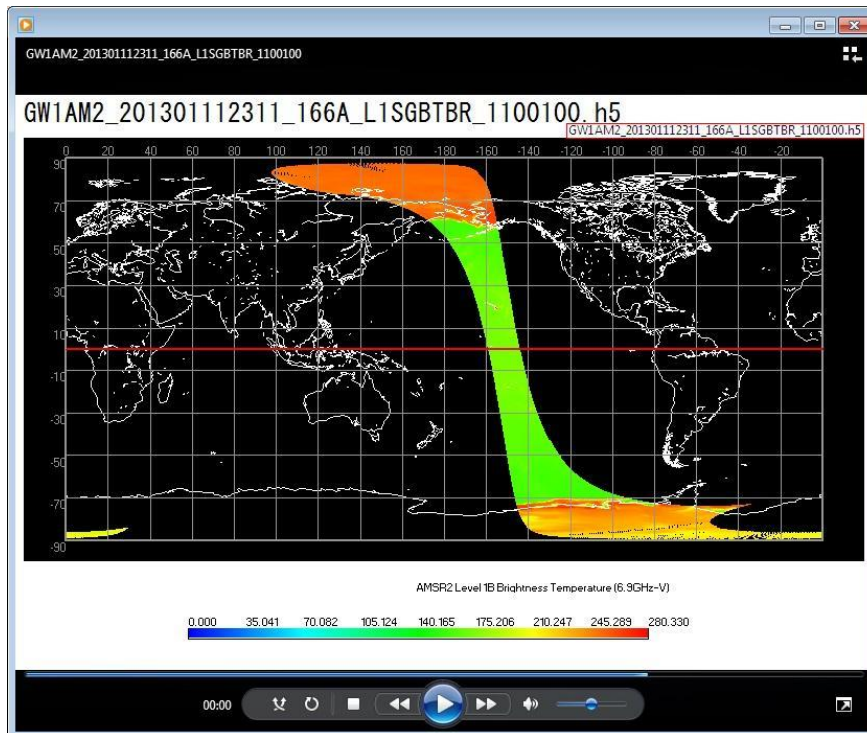

Fig. 4.1.1.4-8 Example of file name display position (upper right)

[Lower]

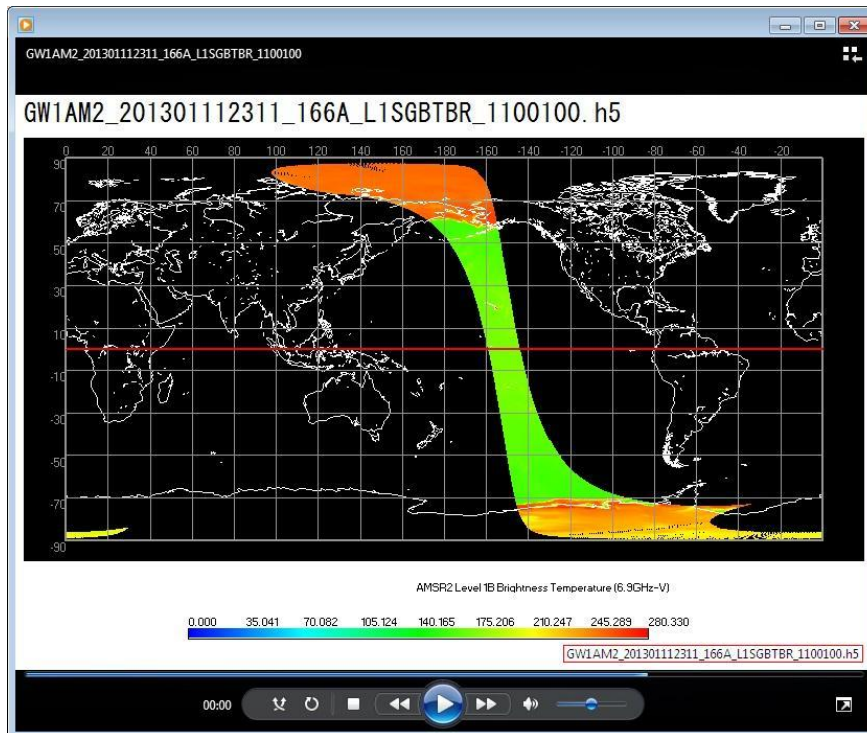

Fig. 4.1.1.4-9 Example of file name display position (lower right)

■ **[Ref]** button

- ① **[Ref]** button is clicked.
- ② It is possible to specify the files to be saved.

You can select the animation file name. You can select the format of an animation file  
(Animation format that can be selected by product is different, please refer to Fig. 4.1.1.4-10)

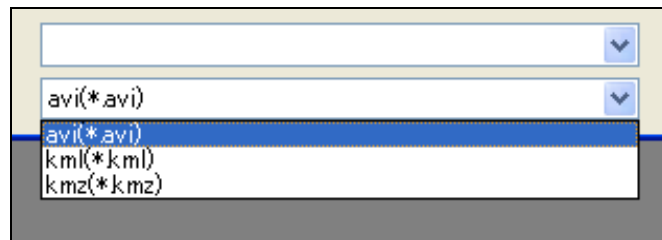

Fig. 4.1.1.4-10 To select animation file of extension

The AVI (Audio Video Interleave) is used as movie or animation file format for Windows. In this tool, AVI file of no compression can be made. Please use the media player such as Windows Media Player for the reproduction of AVI file.

KML (Keyhole Markup Language) is a file format used to display geographic data on Google Earth™. The KML file made by this function corresponds to the function of timeline of Google Earth™.

About more information of Google Earth™, please refer to Google Earth™ Web page (<http://earth.google.com/intl/en/>).

KMZ file format is zipped KML files and their related images.

KMZ file format can be displayed by the correspondence application such as Google Earth™ as well as KML.

■ **[Make]** button

- ① **[Make]** button is clicked.
- ② an animation file of the AMSR2 product is created.

■ **[Cancel]** button

- ① **[Cancel]** button is clicked.
- ② All settings shown in the dialog are canceled and the dialog is closed.

#### 4.1.1.5. Make AMSR/AMSR-E Product Animation

If the [Make AMSR/AMSR-E Product Animation] subsidiary menu is chosen, [Make AMSR/AMSR-E Product Animation Dialog] is displayed, and the animation file of the AMSR/AMSR-E product can be created.

How to create the animation file is explained. [Make AMSR/AMSR-E Product Animation] layout is shown in Fig. 4.1.1.5-1.

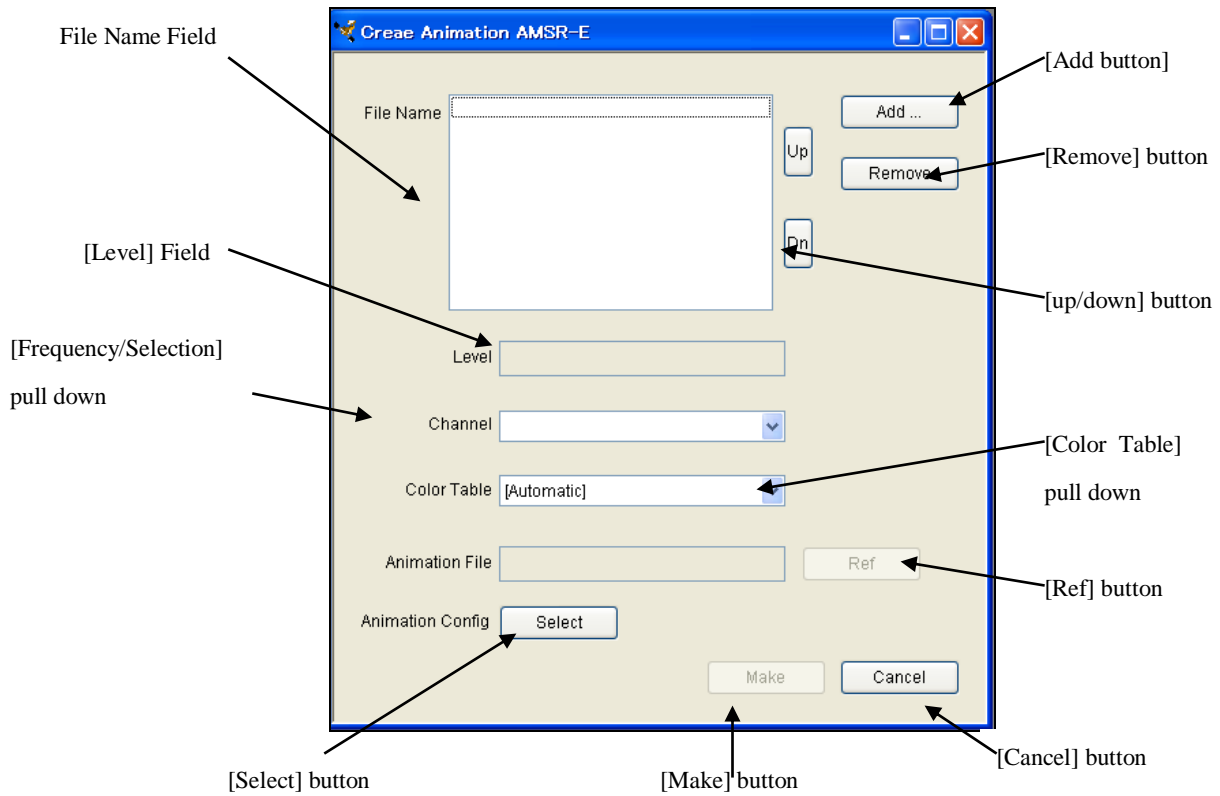

Fig. 4.1.1.5-1 Make AMSR/AMSR-E Product Animation Dialog

■ File Name Field

- ① In this field, the specified file name of AMSR/AMSR-E product is displayed.
- ② It is possible to specify files by using [Add] button or drag & drop operation (Please refer to 4.1.1.5-2).

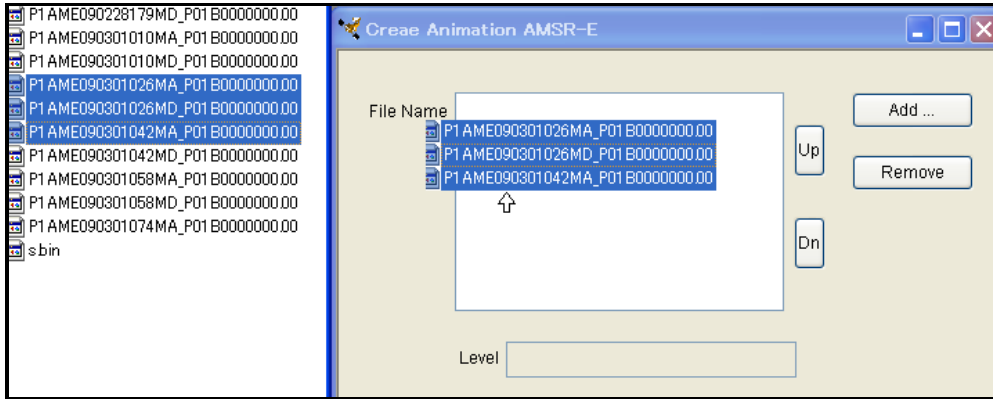

Fig. 4.1.1.5-2 Drag & drop operation

You must select same product level of files. (Case of Level 3, you must also select same projection.) The product level will be displayed on [Level] field.

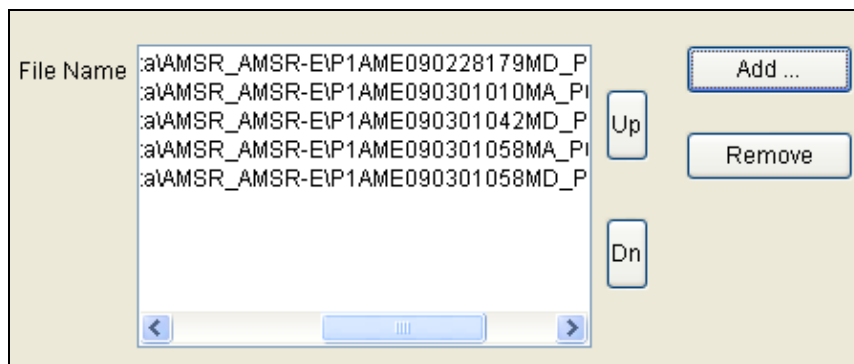

Fig. 4.1.1.5-3 Result of addition to File Name Field

The added file displayed on a [File Name Field]. The number of files that can be specified for this list is decided depending on the number of maximum files set in the configuration setting.



■ **[Add]** button

- ① **[Add]** button is clicked.
- ② **[Open]** dialog that Windows offers is displayed.
- ③ The file of the AMSR/AMSR-E product added to **[File Name Field]** can be selected.

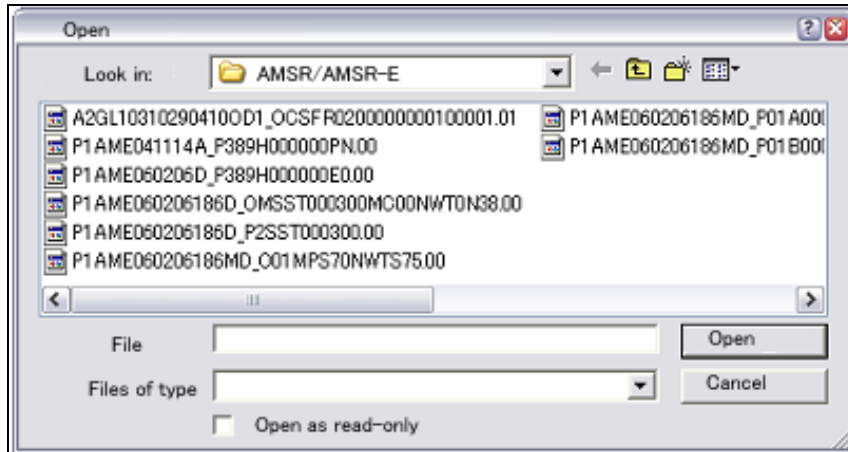

Fig. 4.1.1.5-4File Select Dialog

■ **[Remove]** button

- ① Select file that delete from file name list.
- ② **[Remove]** button is clicked.
- ③ It is possible to delete a file from file name list in **[Make AMSR/AMSR-E Product Animation]** by selecting file name.

■ **[up/down]** button

- ① Select file that changes the order from file name list.
- ② **[up/down]** button is clicked.
- ③ The order of filing "file name list" can be changed.

■ **[Frequency selection]** pull down

Select a channel.

■ **[Color Table]** pull down

- ① The **[Color Table]** title to display from this pull-down can be selected.

■ **[Select]** button

- ① **[Select]** button is clicked
- ② **[Animation Output Setting Dialog]** is displayed.

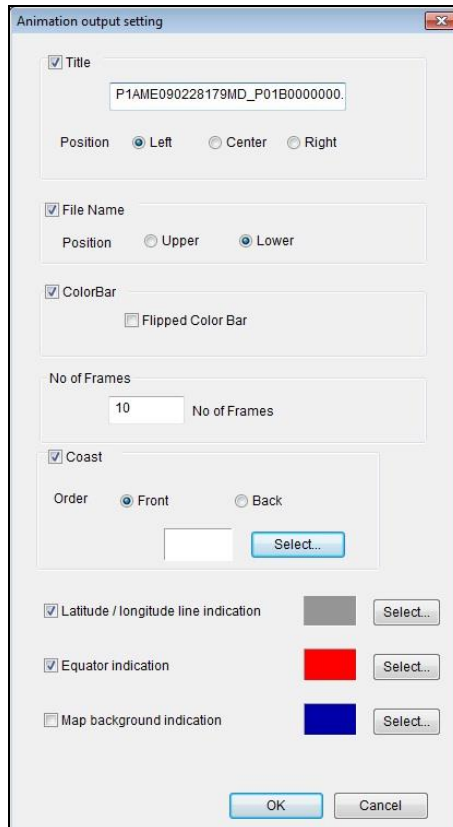

Fig. 4.1.1.5-5 [Animation Output Option] dialog

If you want to display **[Title]**, **[Color Bar]**, **[File Name]**, **[Coast]**, **[Latitude and longitude]**, **[Equator]** and **[Background]** information, please mark each check box.

Moreover, color of each line, display position of **[Title]** and **[File Name]**, and the order of displaying **[Coast]** can be specified. The display position of **[Title]** and **[File Name]** are specified from the following two kinds.

Additionally, please refer to "Image output option" (Chapter 4.3.4) and "Map layer" (Chapter 4.3.5) for more detail information.

[Upper]

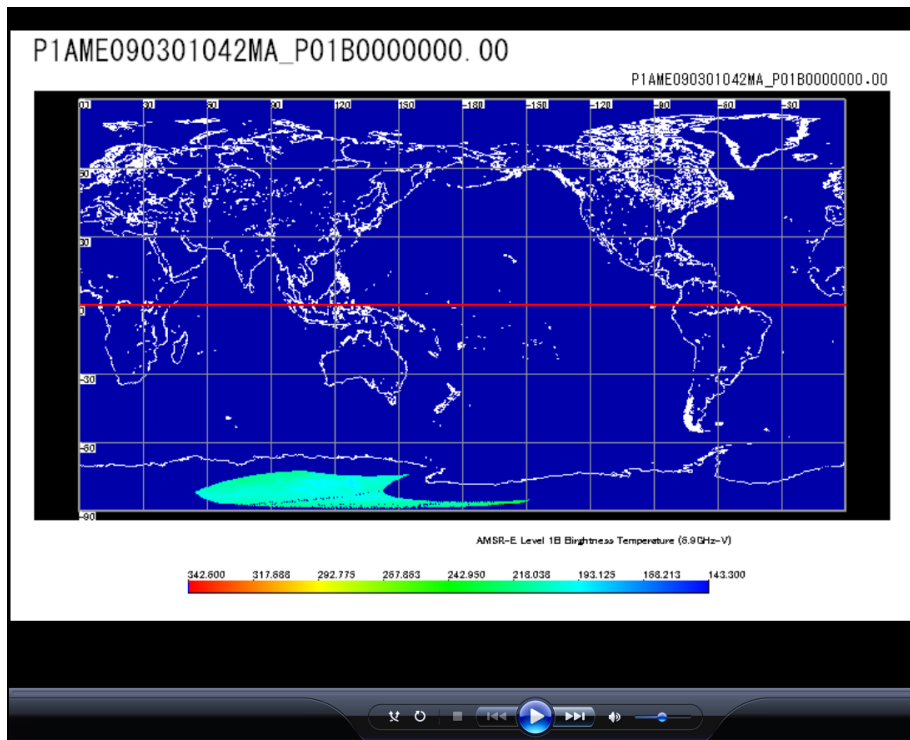

Fig. 4.1.1.5-6 Example of file name display position (upper right)

[Lower]

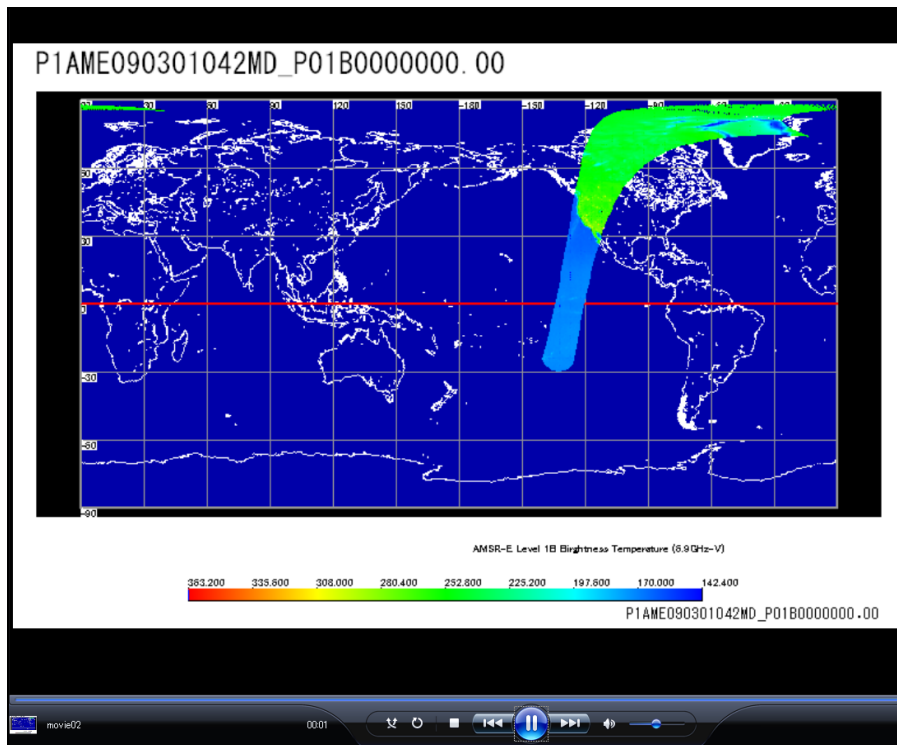

Fig. 4.1.1.5-7 Example of file name display position (lower right)

■ **[Ref]** button

- ① **[Ref]** button is clicked.
- ② It is possible to specify the files to be saved.

You can select the animation file name. You can select the format of an animation file (Animation format that can be selected by product is different, please refer to Fig. 4.1.1.5-8.)

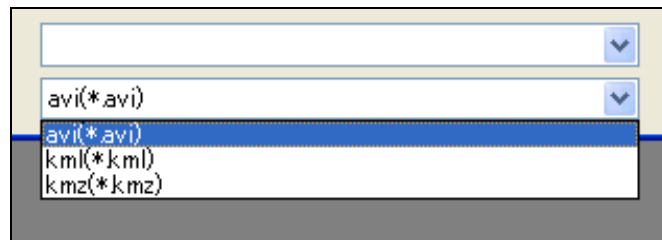

Fig. 4.1.1.5-8 To select animation file of extension

The AVI (Audio Video Interleave) is used as movie or animation file format for Windows. In this tool, AVI file of no compression can be made. Please use the media player such as Windows Media Player for the reproduction of AVI file.

KML (Keyhole Markup Language) is a file format used to display geographic data on Google Earth™. The KML file made by this function corresponds to the function of timeline of Google Earth™.

About more information of Google Earth™, please refer to Google Earth™ Web page (<http://earth.google.com/intl/en/>).

KMZ file format is zipped KML files and their related images.

KMZ file format can be displayed by the correspondence application such as Google Earth™ as well as KML.

■ **[Make]** button

- ① **[Make]** button is clicked.
- ② an animation file of the AMSR/AMSR-E product is created.

■ **[Cancel]** button

- ① **[Cancel]** button is clicked.
- ② All settings shown in the dialog are canceled and the dialog is closed.

#### 4.1.2. Save as Image

When you select [**Save as Image**] menu, you can save the displayed image on a window as a file with JPEG, TIFF, PNG or Bitmap. A default output form is [**JPEG**]. Moreover, the default of a preservation file name is set to [**GRANULE\_ID.jpg**]. Please select [**Save as Image**] pull down from the File Menu. Then [**Image File**] dialog will be popped up. [**Image File**] dialog layout is shown in Fig. 4.1.2-1.

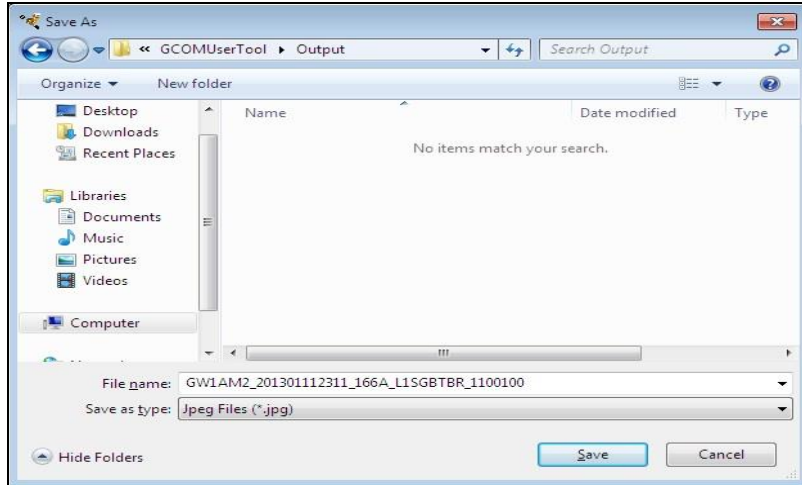

Fig. 4.1.2-1 Image File Dialog

The example of preservation of a picture is shown in Fig. 4.1.2-2.

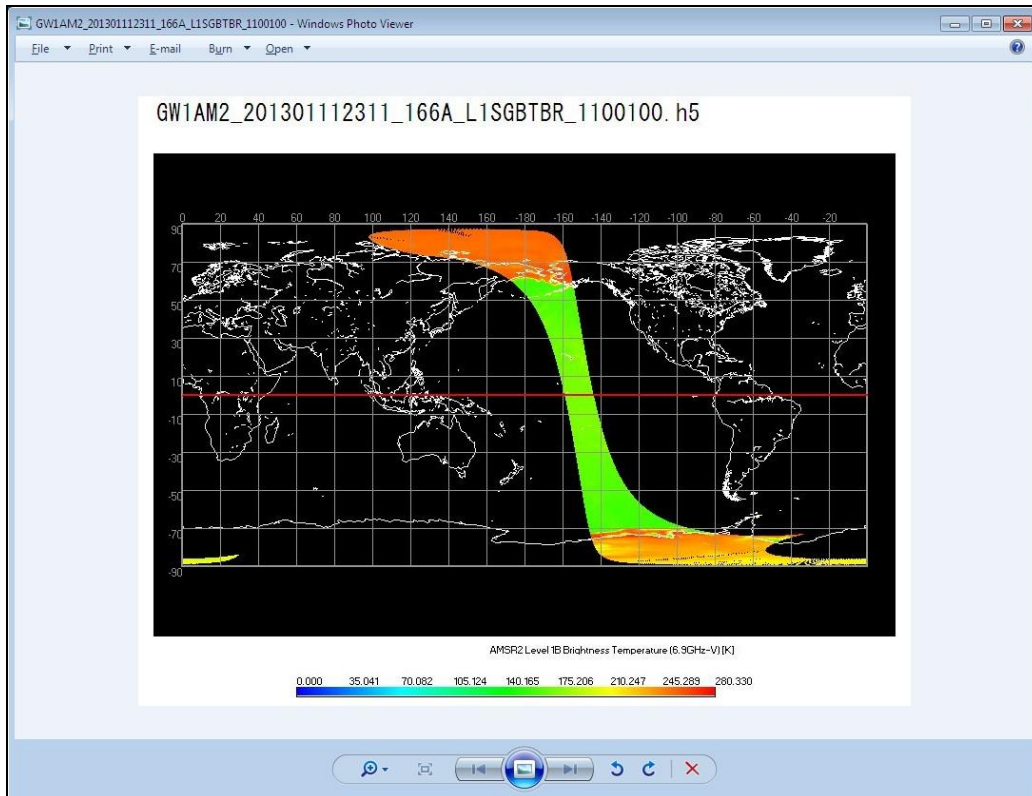

Fig. 4.1.2-2 Example of preservation of an image

#### 4.1.3. Save as KML (KMZ)

When you select [**Save as KML (KMZ)**] menu, you can save the displayed image on a window as a file with KML Format. Moreover, when the area is specified by SELECT mode, the image within the selected area can be saved. About SELECT mode, please refer to [**4.2.9. SELECT Mode**].

Please select [**Save as KML (KMZ)**] pull down from the File Menu. Then [**KML File**] dialog will be popped up. [**KML File**] dialog layout is shown in Fig. 4.1.3-1. Choose KML or KMZ file format.

The KML file format details please refer to [appendix A.3 KML File Format].

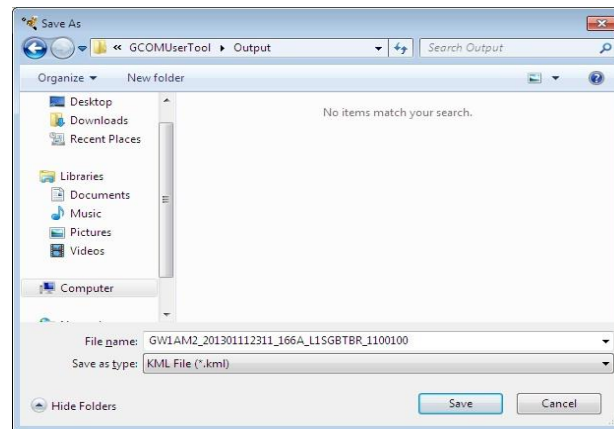

Fig. 4.1.3-1 KML File Save Dialog

#### Note 1) KML (Keyhole Markup Language)

KML (Keyhole Markup Language) file is the file which stored the KML tag for displaying the picture file of AMSR/AMSR-E/AMSR2 (Combined) on Google Earth Client(R).

#### Note 2) KMZ form

It is compression and a form that does the archive as for the file of the KML form (And, relating picture file etc.). The file of the KMZ form is KML similar form, and Google Earth Client(R). It is possible to display it by the correspondence application.

#### 4.1.4. Save as Binary

When you select **[Save as Binary]** menu you can save the displayed image on a window as a file with Binary Format. The byte order of preservation data can be specified **[big endian]** and **[little endian]**.

Please refer to **[4.3.3. User Setting]** about the select byte order. Please select **[Save BIN Data]** pull down from the File Menu. Then **[Binary File Save]** dialog will be popped up. **[Binary File Save]** dialog layout is shown in Fig. 4.1.4-1. Specifying the file name, please click the save button.

The default of a preservation file name is set to **[GRANULE\_ID.bin]**.

The Binary file format details please refer to **[appendix A.1 Binary File Format]**.

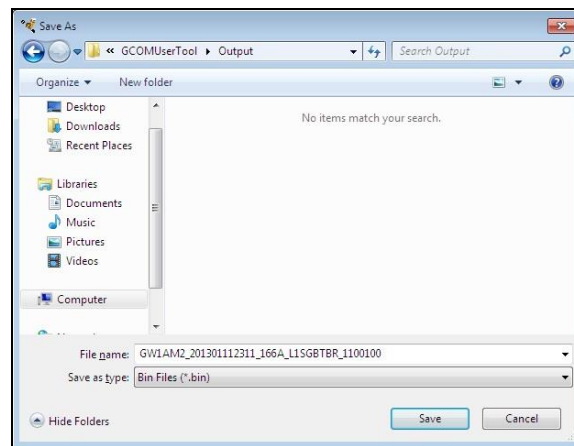

Fig. 4.1.4-1 Binary File Save Dialog

#### 4.1.5. Save as CSV

If you click this **[Save as CSV]** menu, the observation data of the area chosen can be saved at the file of CSV. There are two subsidiary menus in a file open menu.

- (1) Save value only
- (2) Save value with Latitude and Longitude

Subsidiary menus are shown in Fig. 4.1.5-1.

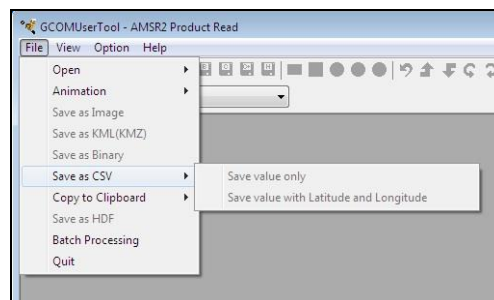

Fig. 4.1.5-1 [Save as CSV] subsidiary menu

#### 4.1.5.1. Save value only

When this subsidiary menu is selected, **[Save as CSV]** is displayed, and can output a CSV file without latitude and longitude for the observation data of the area chosen. **[Save as CSV]** layout is shown in Fig. 4.1.5-2. But there are some cases that the file cannot be saved because of the display condition of resolution etc. In these cases, the error message is displayed. If so, please follow the message.

The default of a preservation file name is set to **[GRANULE\_ID.csv]**.

The CSV file format details please refer to [appendix A.2 CSV File Format].

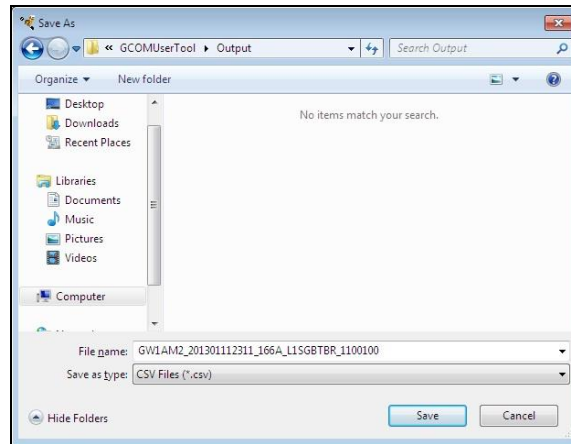

Fig. 4.1.5-2 Save as CSV Dialog

#### 4.1.5.2. Save value with Latitude and Longitude

When this subsidiary menu is selected, **[Save as CSV]** is displayed, and can output a CSV file with latitude and longitude for the observation data of the area chosen. **[Save as CSV]** layout is shown in Fig. 4.1.5-2. But there are some cases that the file cannot be saved because of the display condition of resolution etc. In these cases, the error message is displayed. If so, please follow the message. Fig. 4.1.5-3 shows an example of the error message.

The CSV file format details please refer to [appendix A.2 CSV File Format].

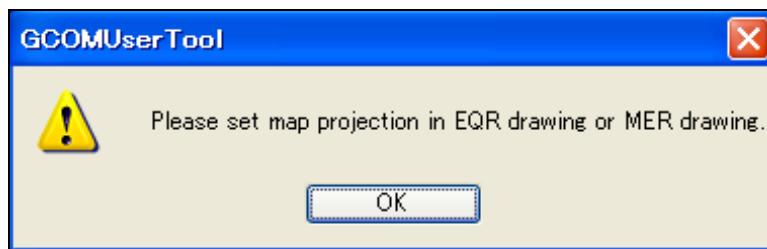

Fig. 4.1.5-3 CSV File Saving Condition Dialog



#### **4.1.6. Copy to Clipboard**

This function is to copy a displayed image to Windows clipboard. You can copy the displayed image to another application easily.

This menu has the following two kind of sub function.

(1) Copy (Window)

Copy an image on the window.

(2) Copy (Selected Area)

Copy the selected area on image window. Please refer to [4.2.9. SELECT Mode] about to select area.

#### 4.1.7. Save as HDF

If you click this [Save as HDF] menu, the observation data of the chosen area can be saved at the HDF file. The data included only one scan in the selected area are output to the output file.

Fig. 4.1.7-1 shows the image of the selected area and output data image.

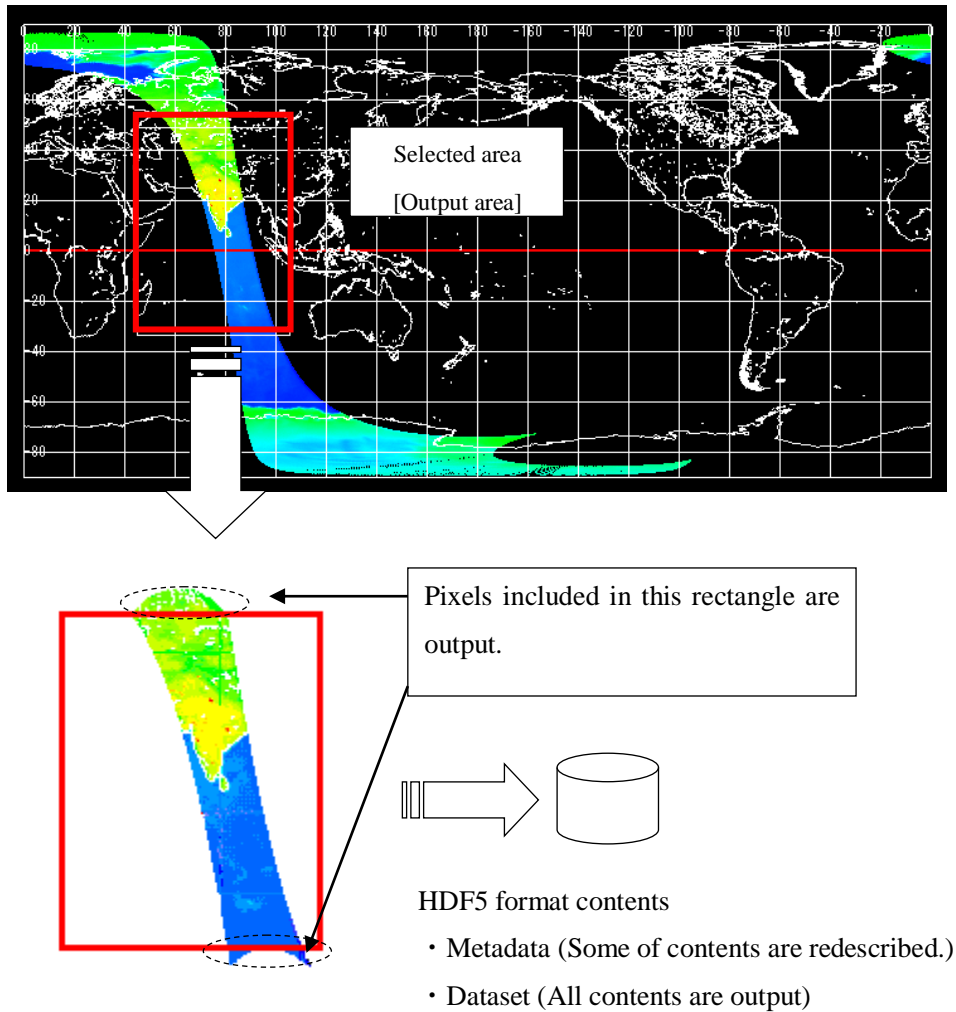

Fig. 4.1.7-1 The image of output HDF product file

The default output HDF file name is shown as below.

[Granule ID]\_[Latitude of upper left][Longitude of upper left][Latitude of upper right][Longitude of upper right].h5

Exp. GW1AM2\_200306060523\_218D\_L2SGPRCHZ1223517\_N36E138N34E140.h5

The latitude and longitude are shown by initial mark and value. (North latitude : N, South latitude : S, East longitude : E, West longitude : W) The latitude and longitude are shown as double digits, triple digits, respectively.

The HDF file format is shown in “**Appendix A.5 HDF format**”.

#### **4.1.8. Execution of batch processing**

When this subsidiary menu is selected, “file open window” is displayed. The batch file selected on the window is read, the content of the command described in the file is analyzed, and it is possible to execute it continuously.

The same processing can be easily repeated by using this function.

The batch file format details please refer to [**Appendix A.8 Batch File**]

#### **4.1.9. Quit**

If you want to terminate GCOM User Tool, please select [**Quit**] pull down from the File Menu.

## 4.2. View Menu

There are 11 subsidiary menus in a file menu.

- (1) Tool Bar
- (2) Status Bar
- (3) Zoom
- (4) Map Projection
- (5) Meta Data
- (6) Color Bar Position
- (7) Zoom Mood
- (8) Pan Mood
- (9) SELECT Mode
- (10) Select Area
- (11) Batch Command History

View menu is shown by Fig. 4.2-1 and explains each menu.



Fig. 4.2-1 View Menu Pull Down

#### 4.2.1. Tool Bar

When [Tool Bar] menu is selected, a tool bar can be made an available or not available. The Window with ToolBar layout is shown in Fig. 4.2.1-1. A ToolBar not available Window layout is shown in Fig. 4.2.1-2.

[The Window with ToolBar layout]

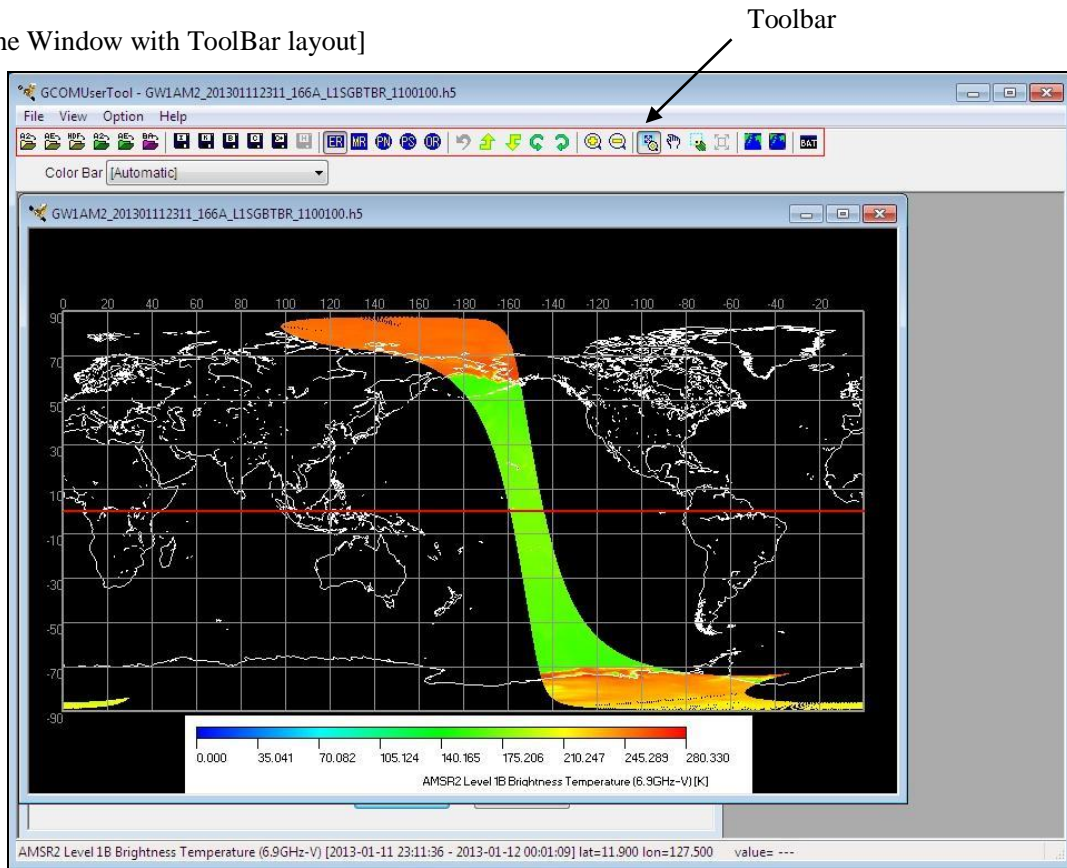

Fig. 4.2.1-1 The Window with ToolBar layout

[The Window without ToolBar layout]

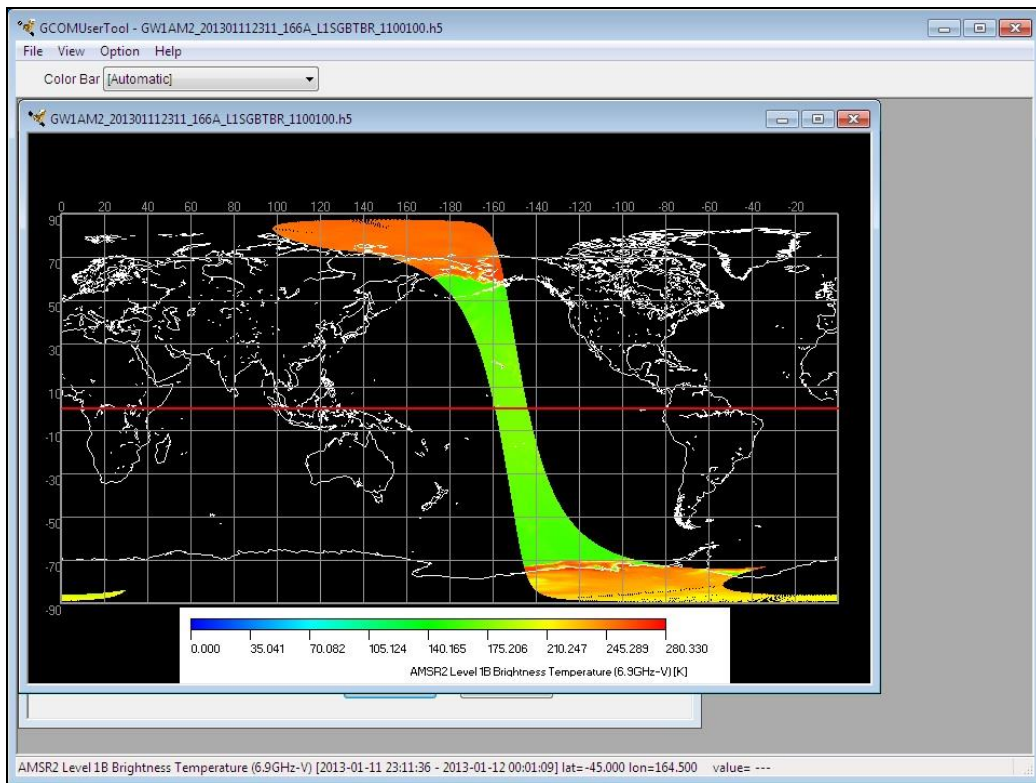

Fig. 4.2.1-2 The Window without ToolBar

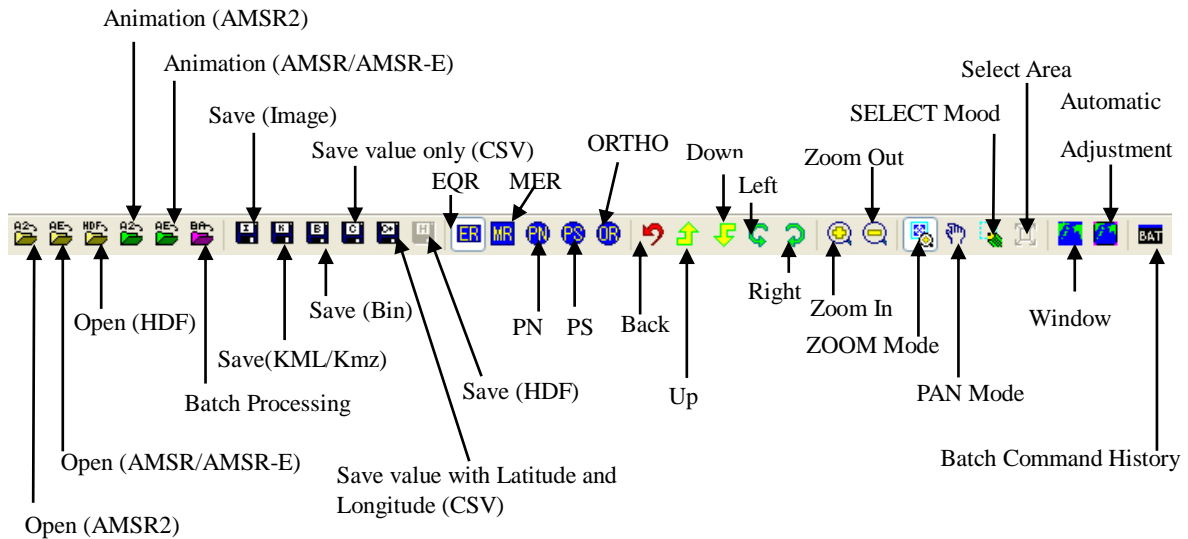

Fig. 4.2.1-3 Tool Bar

There are buttons on [**Tool Bar**] and some of them are not available until an image window is displayed.

[Image Window is displaying]



Fig. 4.2.1-4 Image Window is displaying

[No Image Window]



Fig. 4.2.1-5 No Image Window

The icon of a tool bar is explained as follows.

(1) [Open(AMSR2)]icon

- ① Click this [**Open (AMSR2)**] icon.
- ② AMSR2 product can be read.

Please refer to [4.1.1.1]. Open AMSR2 Products about reading of an AMSR2 product.

(2) [Open(AMSR/AMSR-E)]icon

- ① Click this [**Open (AMSR/AMSR-E )**] icon
- ② AMSR/AMSR-E product can be read.

Please refer to [4.1.1.2 Open AMSR/AMSR-E Products] about reading of a AMSR/AMSR-E product.

(3) [Open(HDF)]icon

- ① Click this [**Open (HDF )**] icon
- ② AMSR2 HDF product can be read.

Please refer to [4.1.1.3 Open AMSR2 Products with HDF output mode] about reading of a AMSR2 HDF product.

(4) [Make Animation (AMSR2)] icon

- ① Click this [**Make Animation (AMSR2)**] icon.
- ② An animation file is created by using AMSR2 products.

. Please refer to [4.1.1.4 Make AMSR2 Product Animation].

(5) [Make Animation (AMSR/AMSR-E)] icon

- ① Click this [**Make Animation (AMSR/AMSR-E)**] icon.
- ② An animation file is created by using AMSR/AMSR-E products.

. Please refer to [4.1.1.5 Make AMSR/AMSR-E Product Animation].

(6) [Batch File Selection] icon

- ① Click this [**Batch File Selection**] icon.
- ② Batch processing is executed.

Please refer to [4.1.8. Execution of batch processing].

(7) [Save (Image)] icon

- ① Click this [**Save (Image)**] icon.
- ② You can save the displayed image on a window as a file with JPEG, TIFF, PNG or Bitmap.

Please refer to [4.1.2. Save as Image] about save of an Image file.

(8) [Save (KML/KMZ)] icon

- ① Click this [**Save (KML/KMZ)**] icon
- ② You can save the displayed image on a window as a file with KML Format.

Please refer to [4.1.3. Save as KML (KMZ)] about save of a KML/KMZ file.

(9) [Save (Binary)] icon

- ① Click this [**Save (Binary)**] icon.
- ② You can save the displayed image on a window as a file with Binary Format.

Please refer to [4.1.4. Save as Binary] about save of a Binary file.

(10) [Save value only (CSV)] icon

- ① Click this [**Save value only (CSV)**] icon.
- ② You can save the displayed image on a window as a file with CSV Format without latitude and longitude information.

Please refer to [4.1.5. Save as CSV] about save of a CSV file.

(11) [Save value with Latitude and Longitude (CSV)] icon

- ① Click this [**Save value only (CSV)**] icon.
- ② You can save the displayed image on a window as a file with CSV Format with latitude and longitude information.

Please refer to [4.1.5. Save as CSV] about save of a CSV file.



(12) [Save (HDF)] icon

- ① Click this [**Save (HDF)**] icon.
- ② You can save the displayed image on a window as a file with HDF Format.

Please refer to [4.1.7. Save as HDF] about save of a HDF file.

(13) [Reset Image Window] icon

- ① Click this [**Reset Image Window**] icon.
- ② The center location of the shown image and/or its zoom ratio is set back to the previous shown image. But the image window size is maintained as the latest.

Please refer to [4.2.3. Zoom] about display reset of image.

(14) [Automatic Adjustment] icon

- ① Click this [**Automatic Adjustment**] icon
- ② The image window size is adjusted automatically.

Please refer to [4.2.3. Zoom].

(15) [Zoom In] icon

- ① Click this [**Zoom In**] icon.
- ② The image is zoomed in, but the center location of the shown image is not changed.

Please refer to [4.2.3. Zoom] about Zoom In of image.

(16) [Zoom Out] icon

- ① Click this [**Zoom Out**] icon.
- ② The image is zoomed out, but the center location of the shown image is not changed.

Please refer to [4.2.3. Zoom] about Zoom Out of image.

(17) [Move Right] icon

- ① Click this [Move Right] icon.
- ② The window of the image is moved to the right with 40 degrees.

The situation of right rotation is shown in Fig. 4.2.1-6.

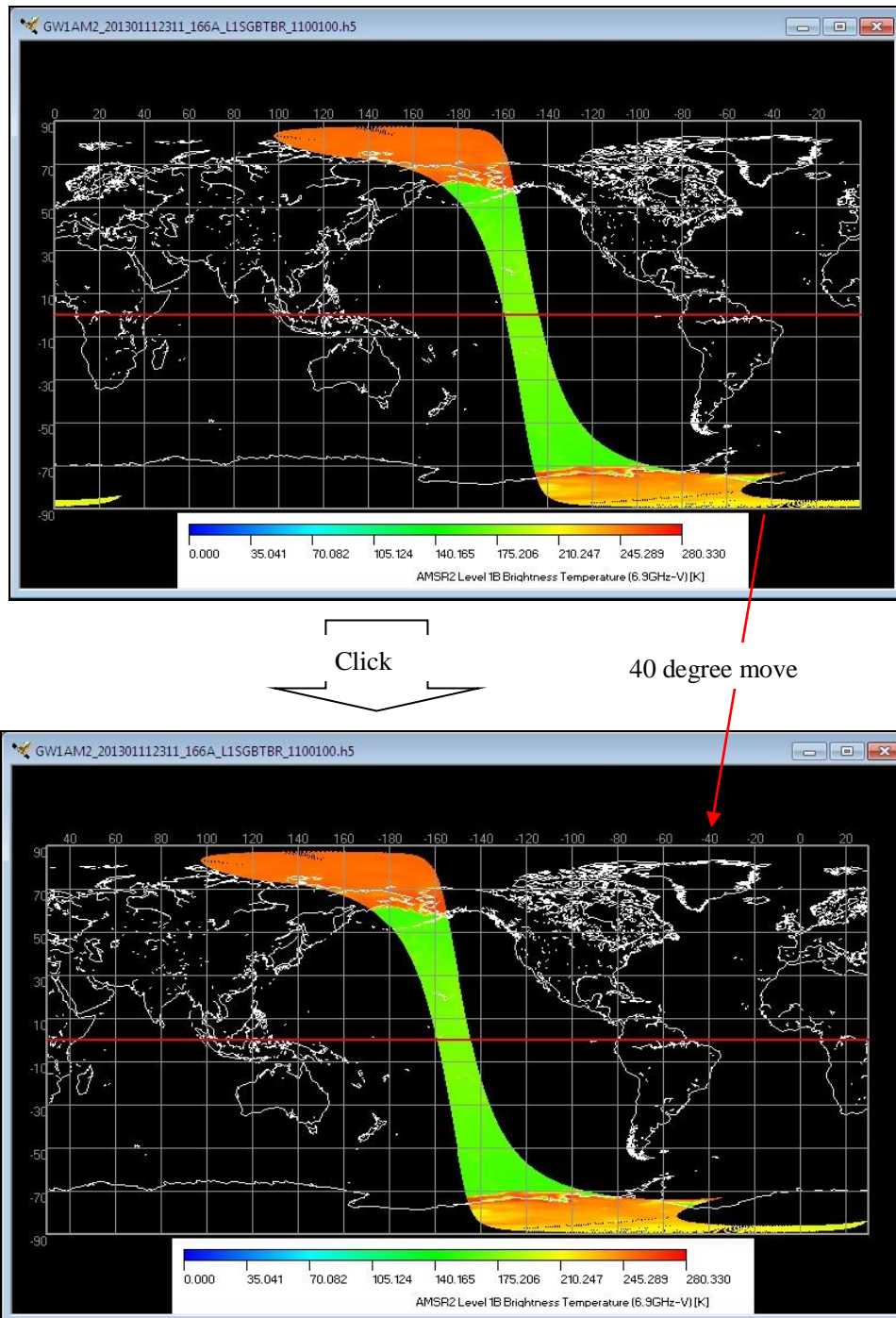

The view point is moved to the right

Fig. 4.2.1-6 Move Right

(18) [Move Left]icon

- ① Click this [Move Left] icon.
- ② The window of the image is moved to the left with 40 degrees.

The situation of left rotation is shown in Fig. 4.2.1-7.

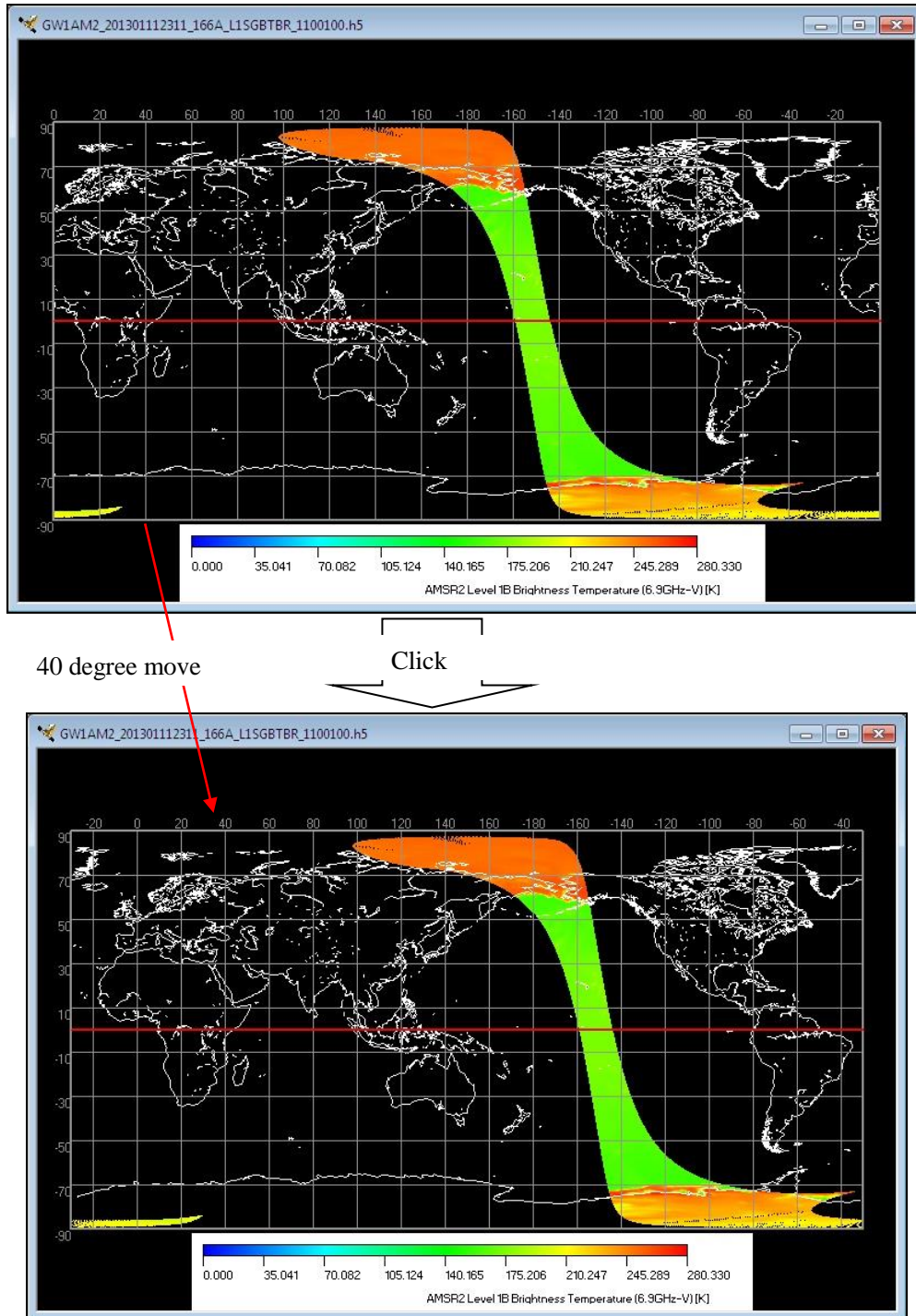

The View point is moved to the left

Fig. 4.2.1-7 Move Left

(19) [Move Up]icon

- ① Click this [Move Up] icon.
- ② The window of the image is moved up.

The situation of moved up is shown in Fig. 4.2.1-8.

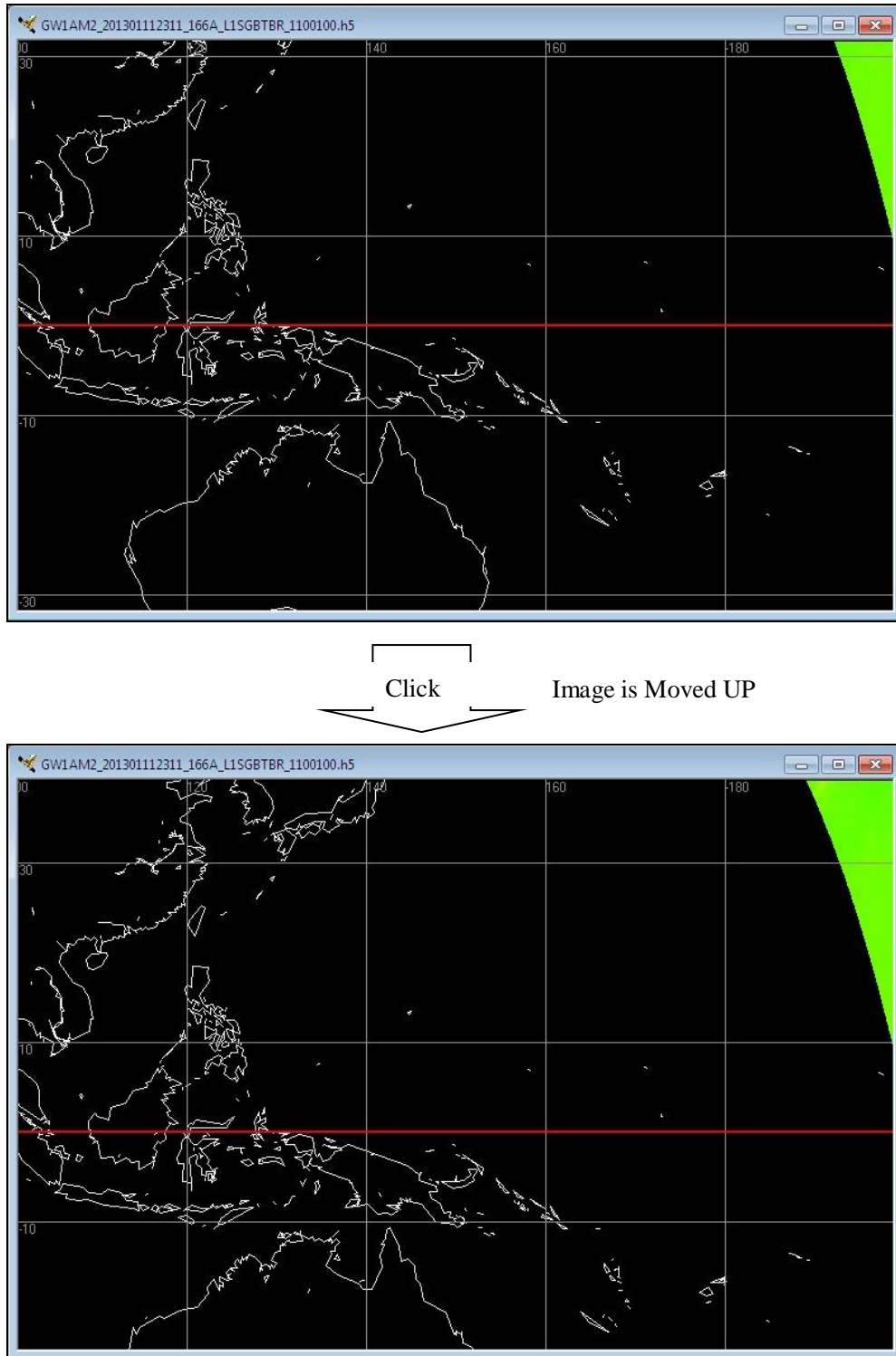
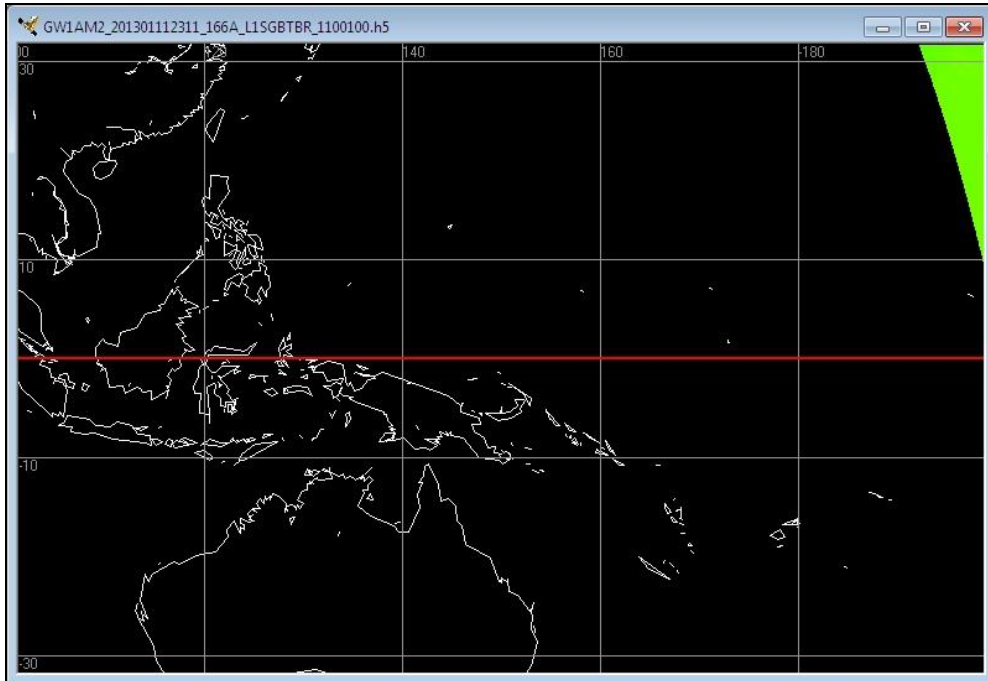

Fig. 4.2.1-8 Move Up

(20) [Move Down]icon

- ① Click this [**Move Down**] icon.
- ② The window of the image is moved down.

The situation of moved down is shown in Fig. 4.2.1-9.



Click Image is Moved Down

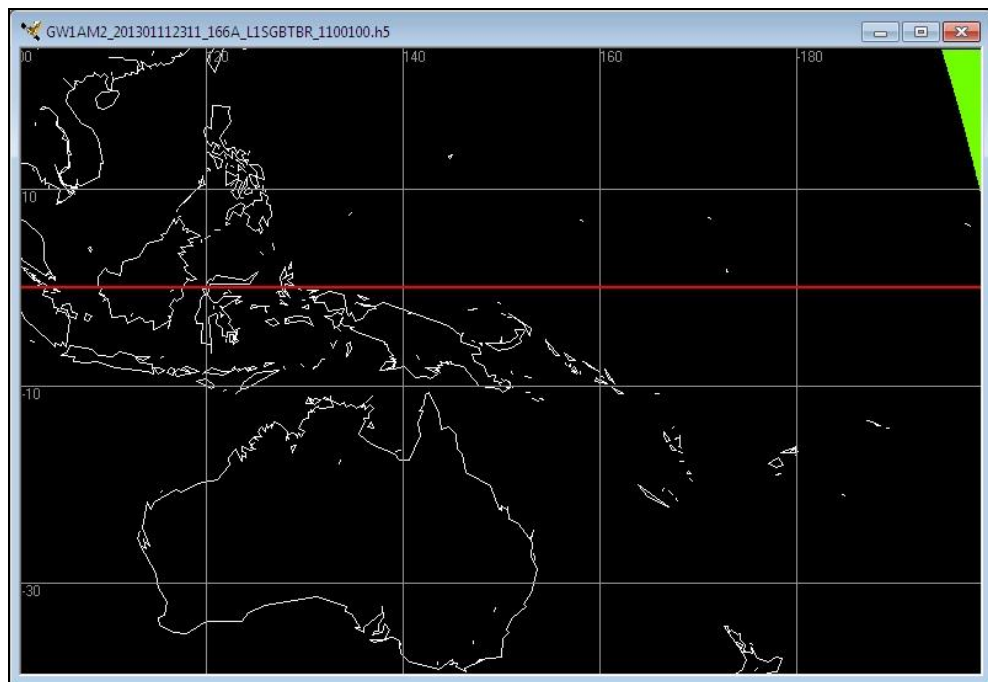

Fig. 4.2.1-9 Move Down

(21) [Back to Previous] icon

- ① Click this [**Back to Previous**] icon.
- ② It can return to the state before operating a map display.  
But it cannot change size of Window.

(22) [PS North] icon

- ① Click this [**PS North**] icon.
- ② An image can be displayed the North Polar stereo Geographic Projection.

Please refer to [**4.2.4. Map Projection**] about Map projection of image.

(23) [PS South] icon

- ① Click this [**PS South**] icon,
- ② An image can be displayed the South Polar stereo Geographic Projection.

Please refer to [**4.2.4. Map Projection**] about Map projection of image.

(24) [Equidistant Geographic] icon

- ① Click this [**Equidistant Geographic**] icon.
- ② An image can be displayed the Equidistant Geographic Projection.

Please refer to [**4.2.4. Map Projection**] about Map projection of image

(25) [Orthographic] icon

- ① click this [**Orthographic**] icon.
- ② An image can be displayed the Orthographic Projection.

Please refer to [**4.2.4. Map Projection**] about Map projection of image.

(26) [Mercator Geographic] icon

- ① Click this [**Mercator Geographic**] icon.
- ② An image can be displayed the Mercator Geographic Projection.

Please refer to [**4.2.4. Map Projection**] about Map projection of image.

(27) [ZOOM Mode] icon

- ① Click this [**ZOOM Mode**] icon.
- ② A specified are can be zoomed in and a domain is chosen on a map, the domain specified with the mouse is zoomed in.

Please refer to [**4.2.7. ZOOM Mode**] about Zoom In of image.

(28) [PAN Mode] icon

- ① Click on this [**PAN Mode**] icon.

- ② A map is moved if mouse moves pushing the left button of a mouse.

Please refer to [**4.2.8. PAN Mode**] about Move of image.

(29) [SELECT Mode] icon

- ① Click on this [**SELECT Mode**] icon.
- ② A specified are can be selected and appoint a area to clip out with a mouse. And it can save the domain that it clipped out.

Please refer to [**4.2.9. SELECT Mode**] about Domain clipping of image

(30) [Select Area] icon

- ① Click on this [**Select Area**] icon.
- ② A specified are can be selected by latitude and longitude and appoint a area to clip out. And it can save the area that it clipped out.

Please refer to [**4.2.10. Select Area**] about Domain clipping of image.

#### 4.2.2. Status Bar

When [Status Bar] menu is selected, a tool bar can be made an available or not available. The Window with StatusBar layout is shown in Fig. 4.2.2-1. The Window without Status Bar layout is shown in Fig. 4.2.2-2.

[The Window with Status Bar layout]

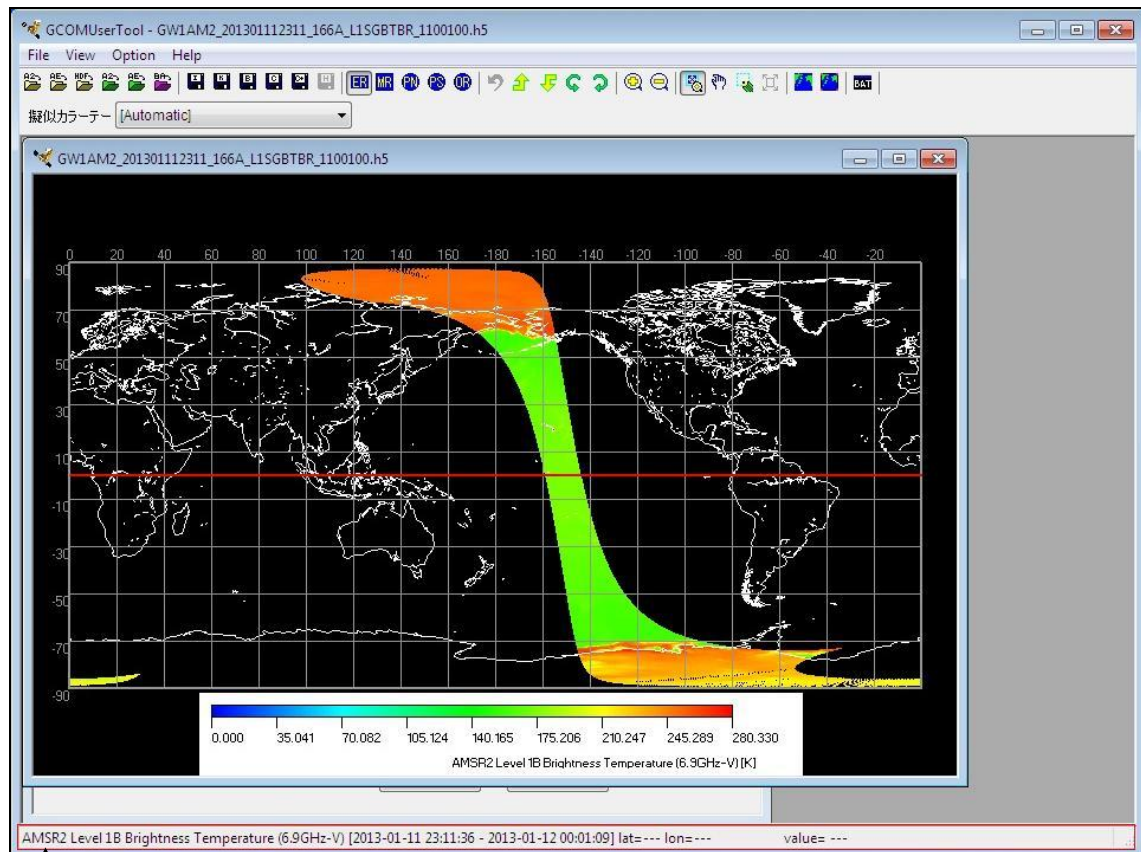

↑  
Status Bar

Fig. 4.2.2-1 The Window with Status Bar layout



[The Window without Status Bar layout]

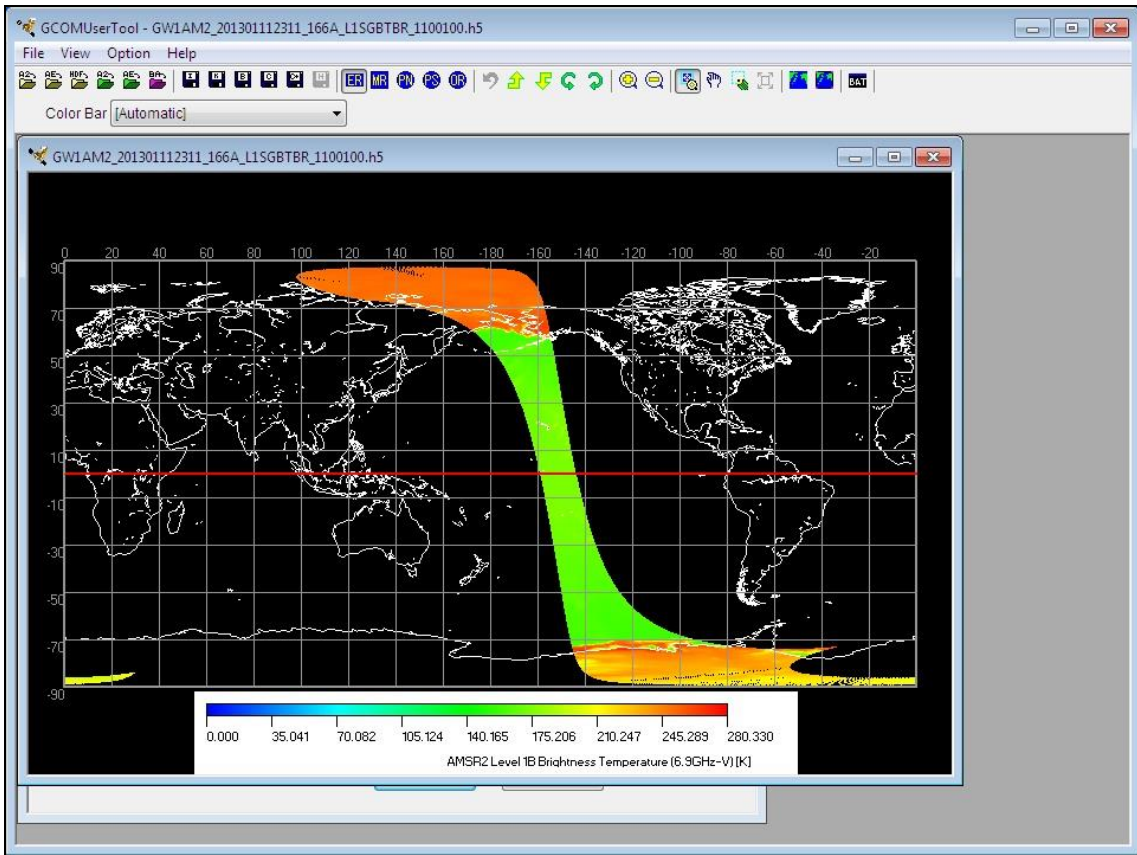

Fig. 4.2.2-2 The Window without Status Bar layout

The latitude and longitude and value observation data (value converted into the amount of physics by the scale factor) which the cursor points on the display is showed. The value observation data on a status bar is displayed only when a setup of resolution is as a mesh display. However, value observation data is not displayed when a picture display is wide range. In such a case, please expand the area that checks value observation data.

When you select a single channel, it is displayed that the information (sensor name, product level, channel and observation time) of the earth observation data on a status bar.

[The product information and Lat / Lon]

AMSR2 Level 1B Brightness Temperature (6.9GHz-V) [2013-01-11 23:11:36 - 2013-01-12 00:01:09] lat=24.400 lon=148.500 value= ---

[The product information and Lat / Lon, observation data]

AMSR2 Level 1B Brightness Temperature (6.9GHz-V) [2013-01-11 23:11:36 - 2013-01-12 00:01:09] lat=44.900 lon=-166.500 value= 162.950

Table 4.2.2-1 Correspondence the table of display method and status bar display item

Status bar display item	Single channel		RGB composite	
	-	Mesh display	-	Mesh display
Sensor name	○	○		
Product level	○	○		
Channel	○	○		
Observation time	○	○		
Observation Lat/Lon	○	○	○	○
Observation data		○		○

### 4.2.3. Zoom

When [Zoom] menu is selected, a picture can be Zoom In and Zoom Out. There are five menus in the file open menu.

- (1) Automatic Adjustment
- (2) Zoom In
- (3) Zoom Out
- (4) Reset Image Window
- (5) Back to Previous

Subsidiary menus are shown in Fig. 4.2.3-1.

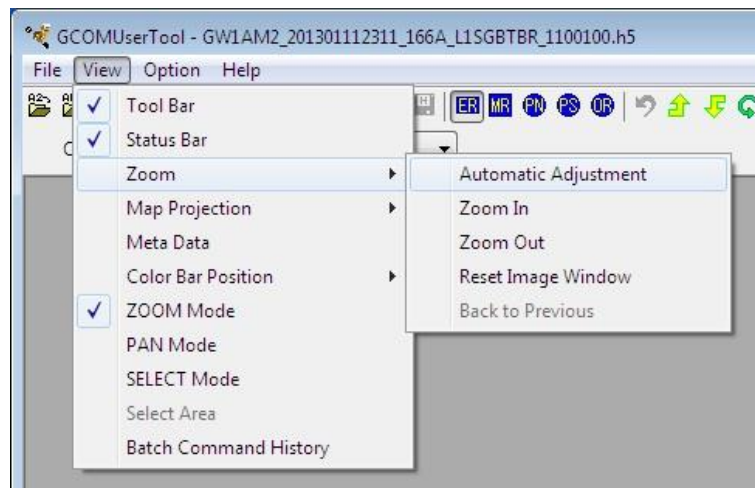

Fig. 4.2.3-1 [Zoom] subsidiary menu

This menu corresponds to the following icons of a tool bar. The tool bar icon corresponding to a subsidiary menu is shown in Fig. 4.2.3-2.

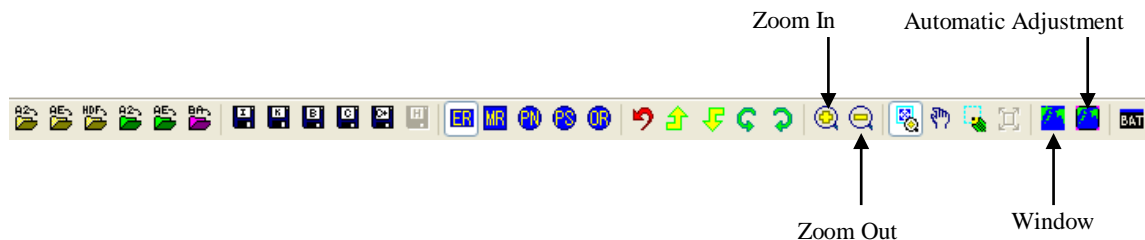

Fig. 4.2.3-2 [Zoom] menu and Tool Bar

It explains each subsidiary menu as follows.

### 4.2.3.1. Automatic Adjustment

When this [Automatic Adjustment] menu is selected, the image window size is adjusted automatically.

The process of this function is shown in Fig. 4.2.3.1-1

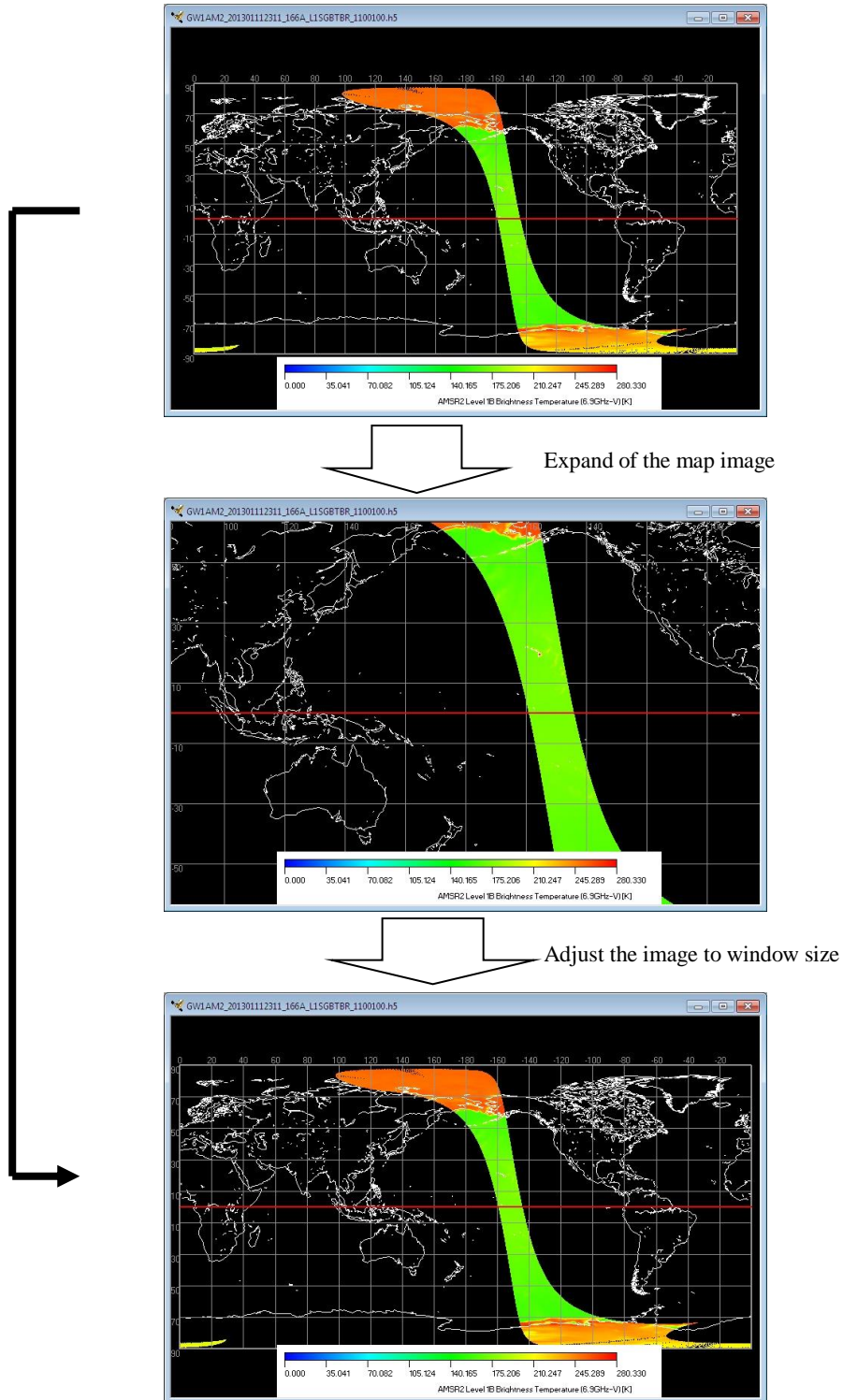

Fig. 4.2.3.1-1 Automatic Adjustment

#### 4.2.3.2. Zoom In

When this [Zoom In] menu is selected, the image is zoomed in but the center location of the shown image is not changed. The map display after zoomed in before zoomed in is shown in Fig. 4.2.3.2-1

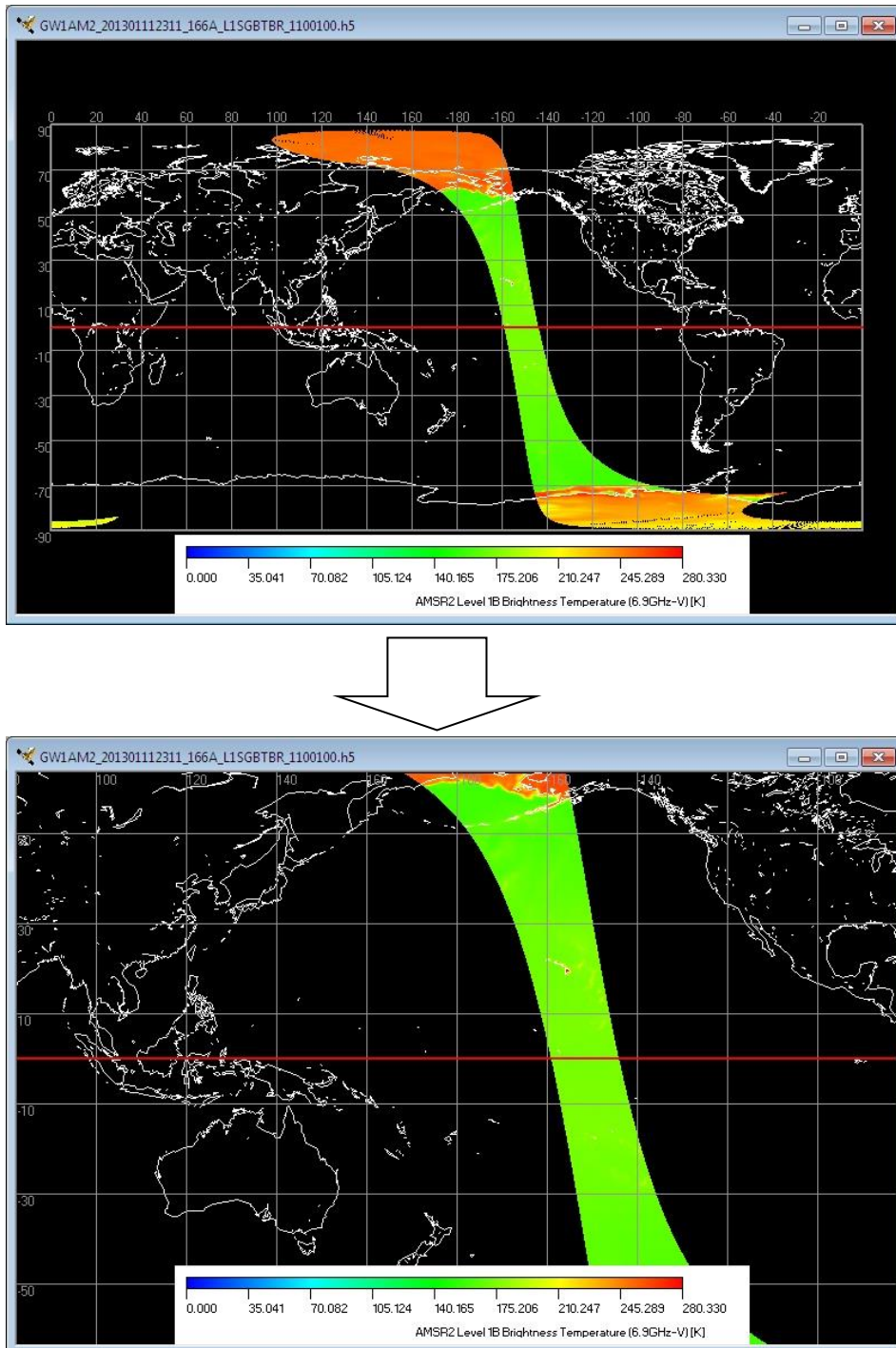

Fig. 4.2.3.2-1 Zoom In

### 4.2.3.3. Zoom Out

When this [Zoom Out] menu is selected, the image is zoomed out but the center location of the shown image is not changed. The map display after zoomed out before zoomed out is shown in Fig.4.2.3.3-1

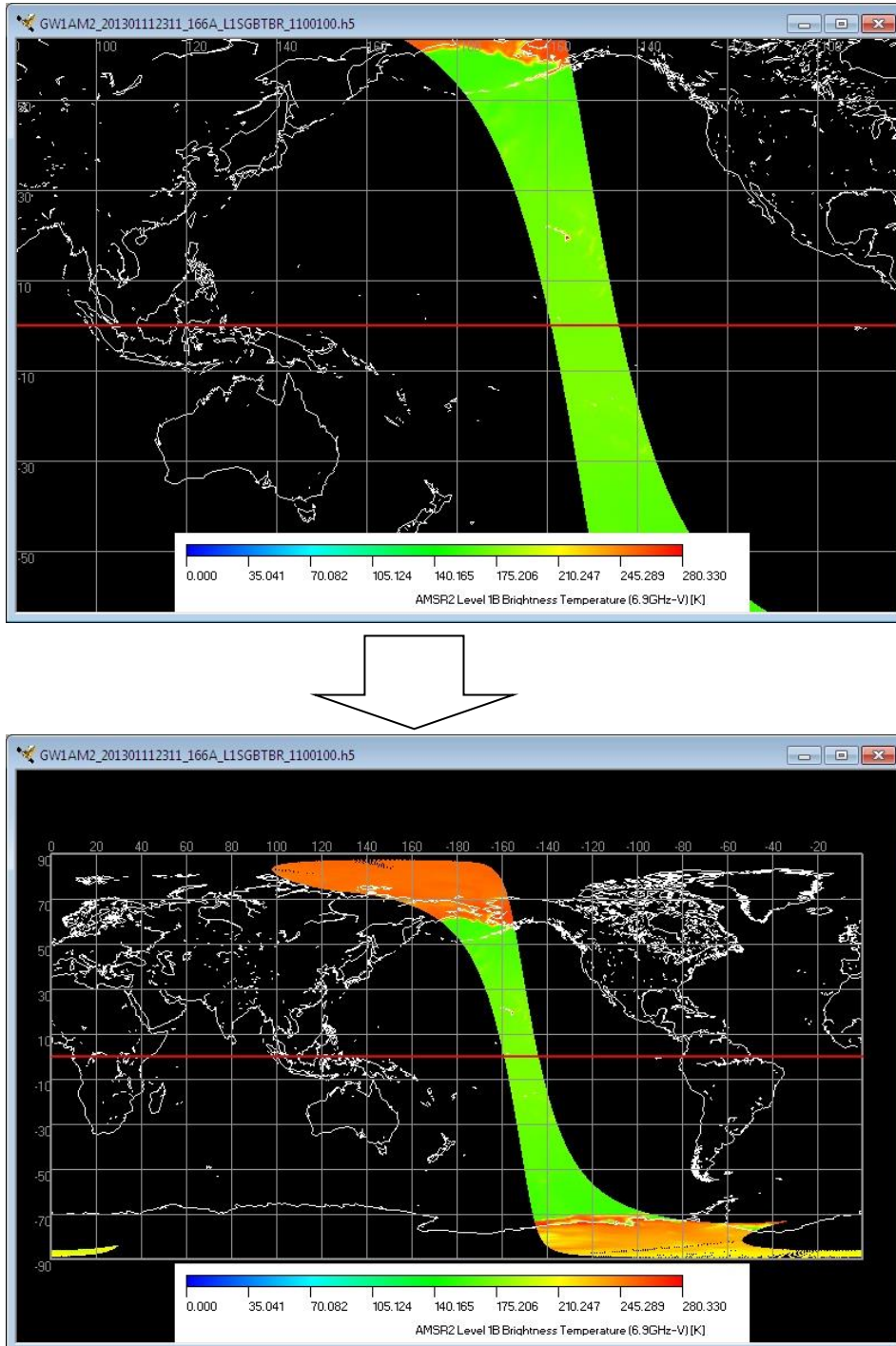

Fig. 4.2.3.3-1 Zoom Out

#### 4.2.3.4. Reset Image Window

The center location of the shown image and/or its zoom ratio is set back to the previous shown image. But the image window size is maintained as the latest.

#### 4.2.3.5. Back to Previous

The center location of the shown image and/or its zoom ratio is set back to the previous shown image. But the image window size is maintained as the latest.

#### 4.2.4. Map Projection

When [Map Projection] menu is selected, the projective technique of a map can be specified. There are four subsidiary menus in the file open menu.

- (1) Equidistant Geographic
- (2) Orthographic
- (3) Polar Stereo Geographic
- (4) Mercator Geographic

Subsidiary menus are shown in Fig. 4.2.4-1

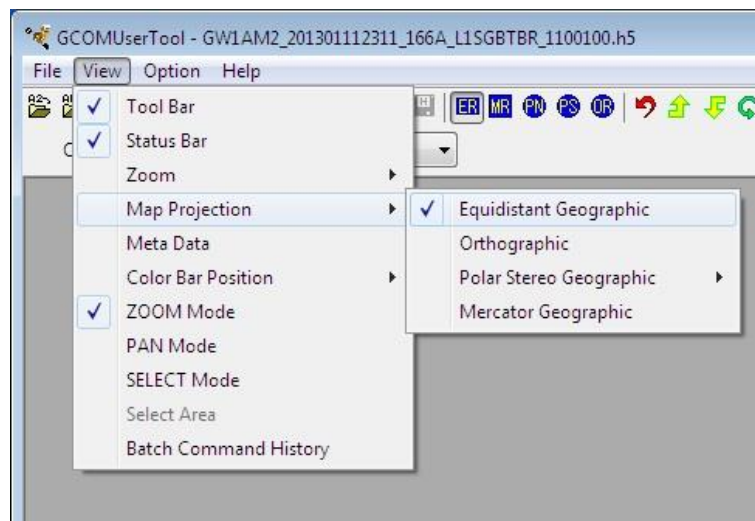

Fig. 4.2.4-1 [Map Projection] subsidiary menu

This menu corresponds to the following icons of a tool bar. The tool bar icon corresponding to a subsidiary menu is shown in Fig. 4.2.4-2.

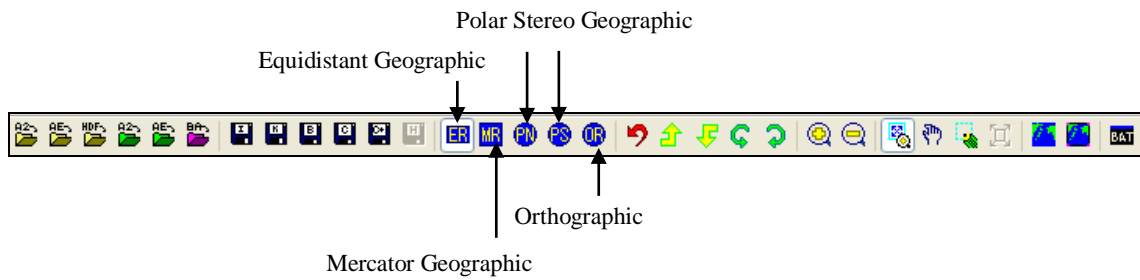

Fig. 4.2.4-2 [Map Projection] menu and Tool Bar

Please refer to [1.3 Object data] about the map projection of AMSR2/AMSR and AMSR-E product

#### 4.2.4.1. Equidistant Geographic

When this [Equidistant Geographic] menu is selected, an image can be displayed by Equidistant projection. A sample is shown in Fig. 4.2.4-3.

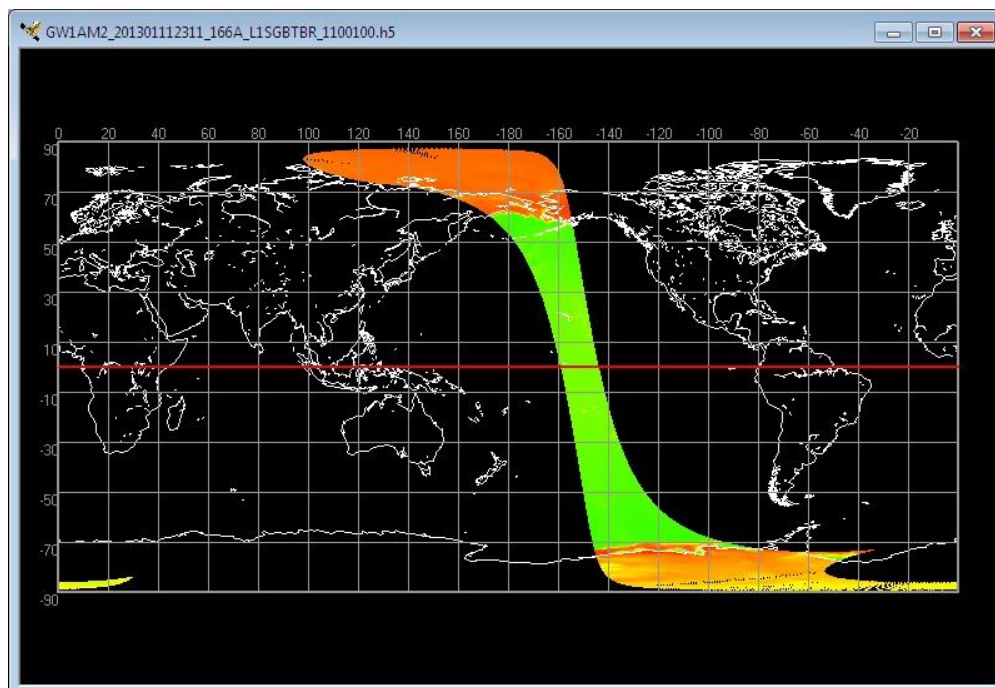

Fig. 4.2.4-3 A Sample Image of Equidistant Geographic



#### 4.2.4.2. Orthographic

When this [Orthographic] menu is selected, an image can be displayed by Orthographic Projection. A sample is shown in Fig. 4.2.4-4.

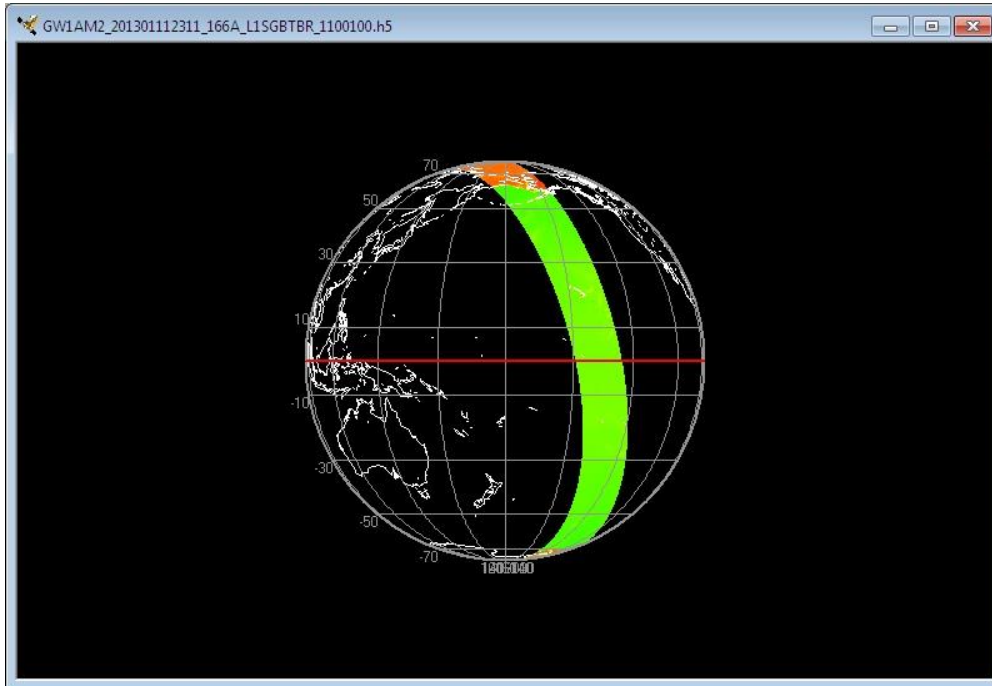

Fig. 4.2.4-4 A Sample Image of Orthographic

#### 4.2.4.3. Polar Stereo Geographic

When this [**Polar Stereo Geographic**] menu is selected, an image can be displayed of Polar Stereo Geographic Projection. There are four subsidiary menus in a file open menu.

- (1) Northern Hemisphere
- (2) Southern Hemisphere
- (3) Both
- (4) Standard longitude

Subsidiary menus are shown in Fig. 4.2.4-5.

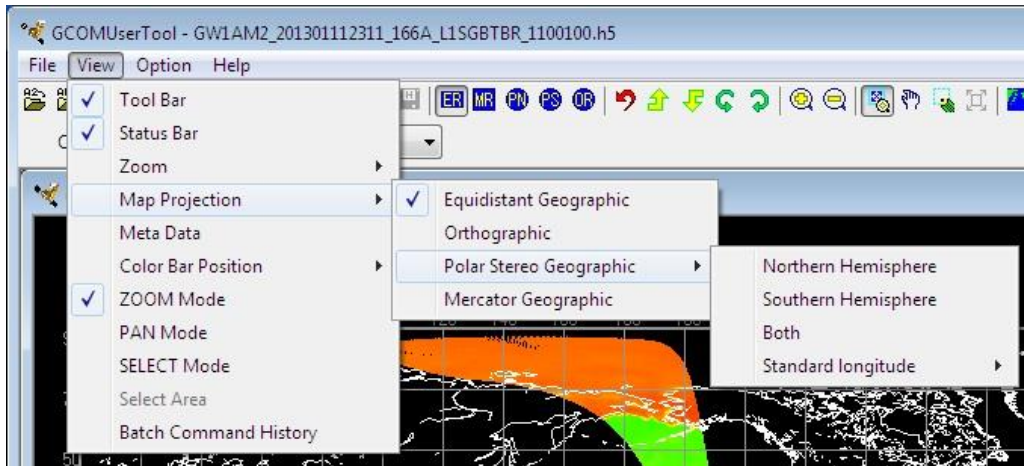

Fig. 4.2.4-5 [**Polar Stereo Geographic**] subsidiary menu

#### 1) Northern Hemisphere

When this [**Northern Hemisphere**] subsidiary menu is selected, an image of Northern Hemisphere can be displayed of Polar stereo Projection. A sample is shown in Fig. 4.2.4-6.

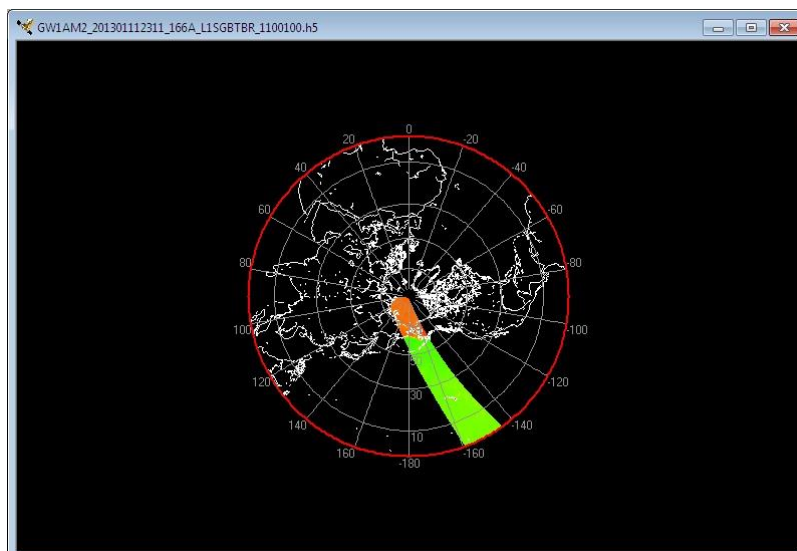

Fig. 4.2.4-6 A sample Image of Northern Hemisphere

2) Southern Hemisphere

When this [**Southern Hemisphere**] subsidiary menu is selected, an image of Southern Hemisphere can be displayed of Polar stereo Projection. A sample is shown in Fig. 4.2.4-7.

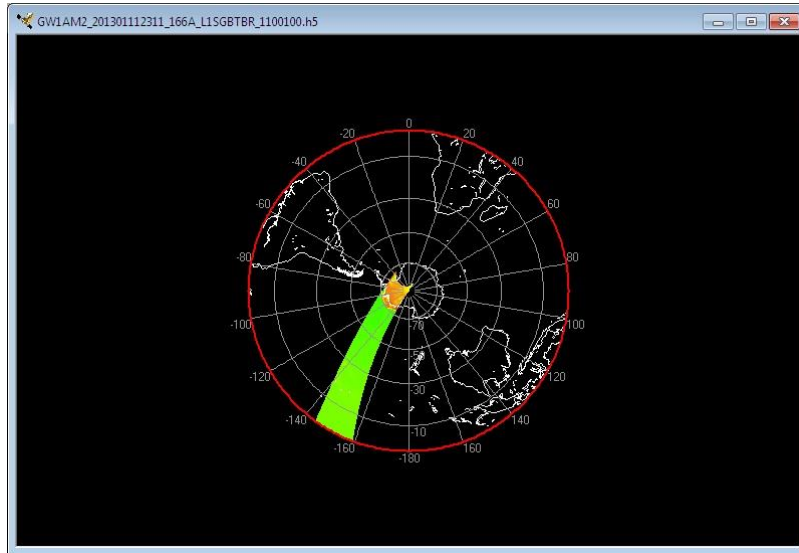

Fig. 4.2.4-7 A sample Image of Southern Hemisphere

3) Both

When this [**Both**] subsidiary menu is selected, an image of Southern Hemisphere and Northern Hemisphere can be displayed of Polar stereo Projection on one window. A sample is shown in Fig. 4.2. 4-8.

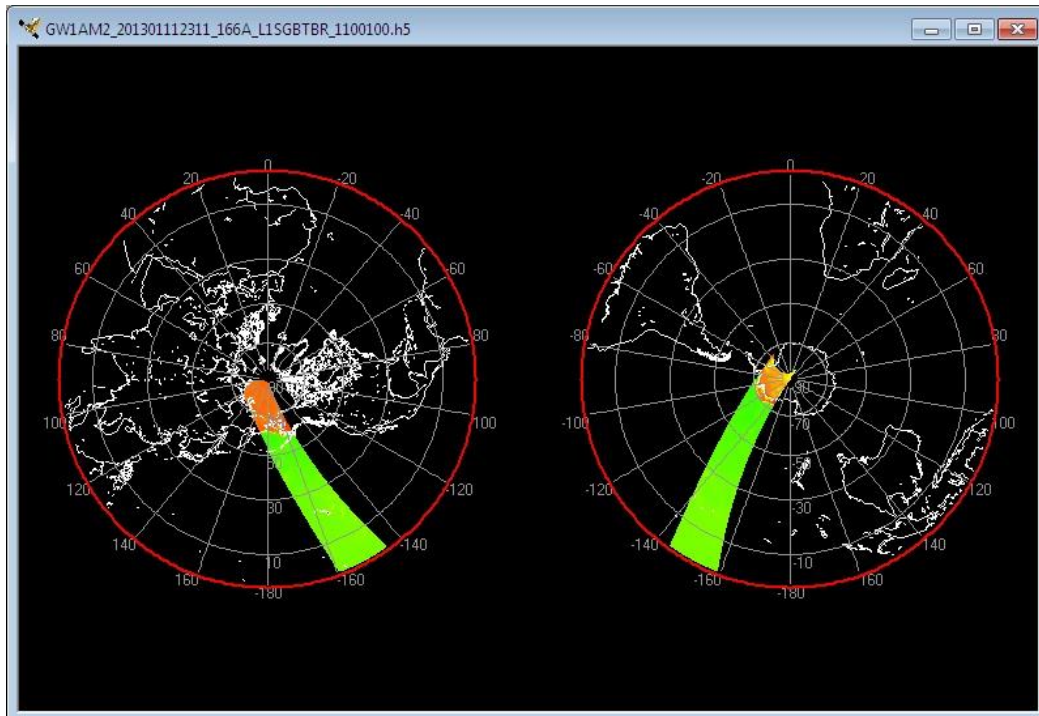

Fig. 4.2.4-8 A Sample Image of Southern Hemisphere and Northern Hemisphere

### 3) Standard longitude

When this [**Standard longitude**] subsidiary menu is selected, It is possible to display it by specifying a standard longitude in the map displayed by Polar stereo Projection. There are eight kinds of Standard longitude that can be selected as follows. (It is 0 degrees in default.)

A sample is shown in Fig. 4.2. 4-9.

- ①0°
- ②45°
- ③90°
- ④135°
- ⑤180°
- ⑥-135°
- ⑦-90°
- ⑧-45°

Product/map of Northern Hemisphere is shown in Fig. 4.2.4-9 in standard longitude 0°

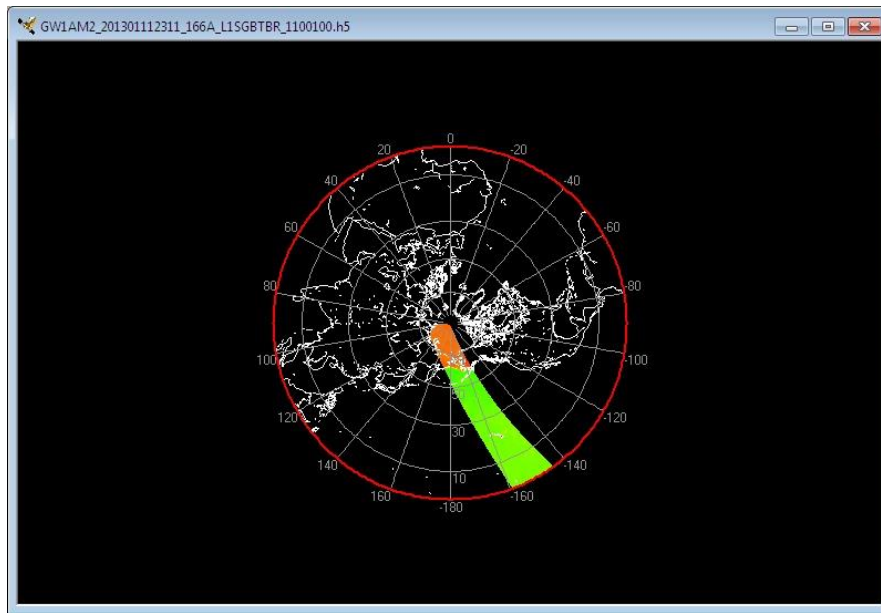

Fig. 4.2.4-9 A Sample Image of Northern Hemisphere in standard longitude 0°

Product/map of Northern Hemisphere is shown in Fig. 4.2.4-10 in standard longitude 90°

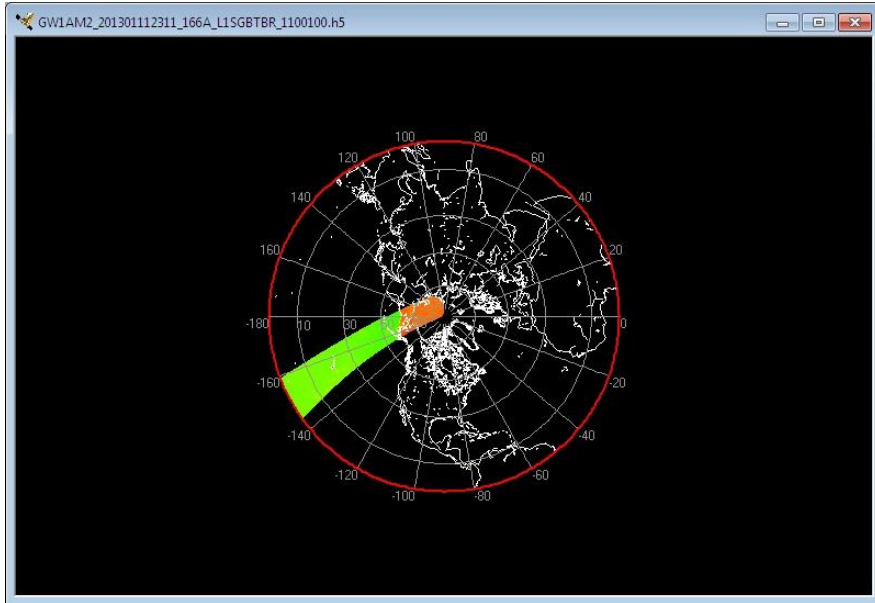

Fig. 4.2.4-10 A Sample Image of Northern Hemisphere in standard longitude 90°

#### 4.2.4.4. Mercator Geographic

When this [Mercator Geographic] subsidiary menu is selected, product/map can be displayed of Mercator Geographic Projection. A sample is shown in Fig. 4.2.4-11.

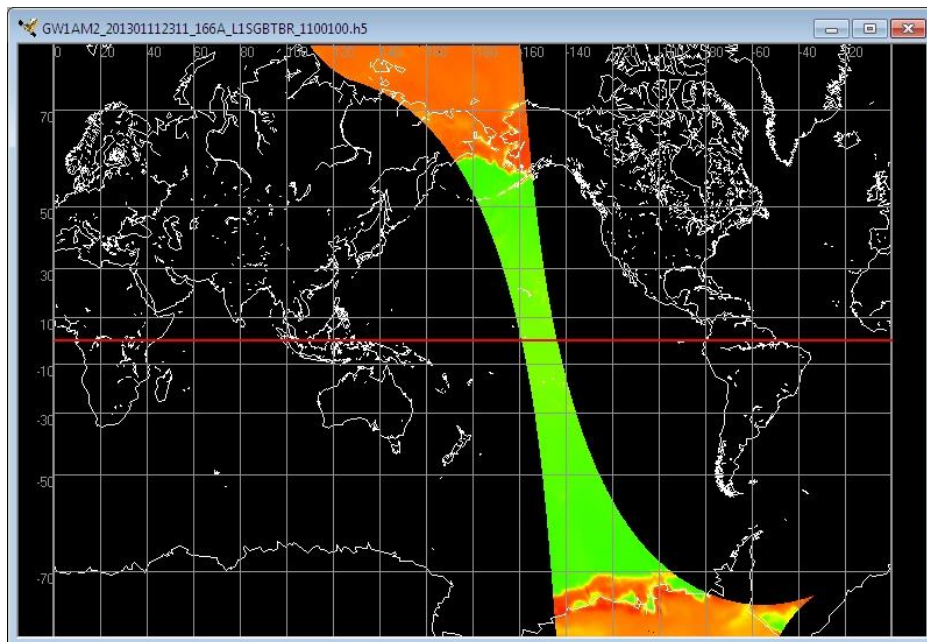
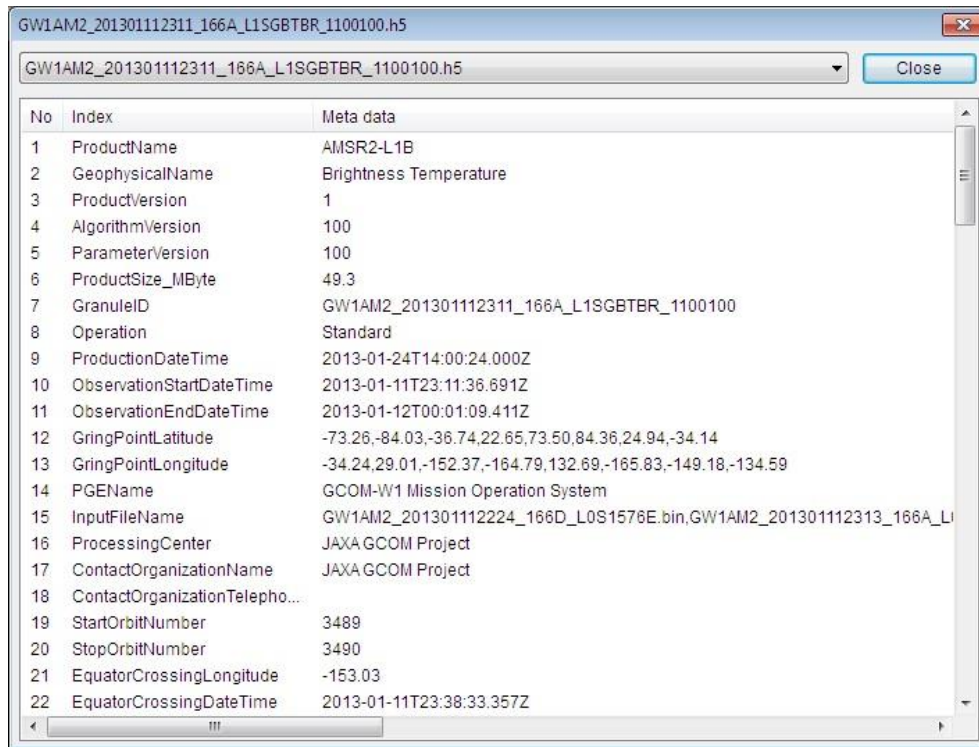

Fig. 4.2.4-11 A sample Image of Mercator Geographic

#### 4.2.5. Meta Data

When [Meta Data] menu is selected, [Meta Information Dialog] is displayed, and a Meta information can be display. If you activate an image window and select [Meta Data] pull down, its [Meta Information Dialog] with the image window is popped up. [Meta Information Dialog] layout is shown in Fig. 4.2.5-1.



No	Index	Meta data
1	ProductName	AMSR2-L1B
2	GeophysicalName	Brightness Temperature
3	ProductVersion	1
4	AlgorithmVersion	100
5	ParameterVersion	100
6	ProductSize_MByte	49.3
7	GranuleID	GW1AM2_201301112311_166A_L1SGBTBR_1100100
8	Operation	Standard
9	ProductionDateTime	2013-01-24T14:00:24.000Z
10	ObservationStartDateTime	2013-01-11T23:11:36.691Z
11	ObservationEndDateTime	2013-01-12T00:01:09.411Z
12	GringPointLatitude	-73.26,-84.03,-36.74,22.65,73.50,84.36,24.94,-34.14
13	GringPointLongitude	-34.24,29.01,-152.37,-164.79,132.69,-165.83,-149.18,-134.59
14	PGEName	GCOM-W1 Mission Operation System
15	InputFileName	GW1AM2_201301112224_166D_L0S1576E.bin,GW1AM2_201301112313_166A_L1
16	ProcessingCenter	JAXA GCOM Project
17	ContactOrganizationName	JAXA GCOM Project
18	ContactOrganizationTelepho...	
19	StartOrbitNumber	3489
20	StopOrbitNumber	3490
21	EquatorCrossingLongitude	-153.03
22	EquatorCrossingDateTime	2013-01-11T23:38:33.357Z

Fig. 4.2.5-1 Meta Information Dialog

■ [Meta Data] pull down menu

- ① Select the product file the meta data displayed.

■ [Close] button

- ① [Cancel] button is clicked.
- ② All setting shown in the dialog is canceled and the dialog is closed.

#### 4.2.6. Color Bar Position

The display method of Color Bar can be changed.

There are two kinds of this subsidiary menu that can be selected as follows.

- ① Vertical
- ② Horizontal

##### 1) Vertical

The color bar can be vertically displayed.

Product/map display where the color bar was vertically displayed is shown in Fig. 4.2.6-1.

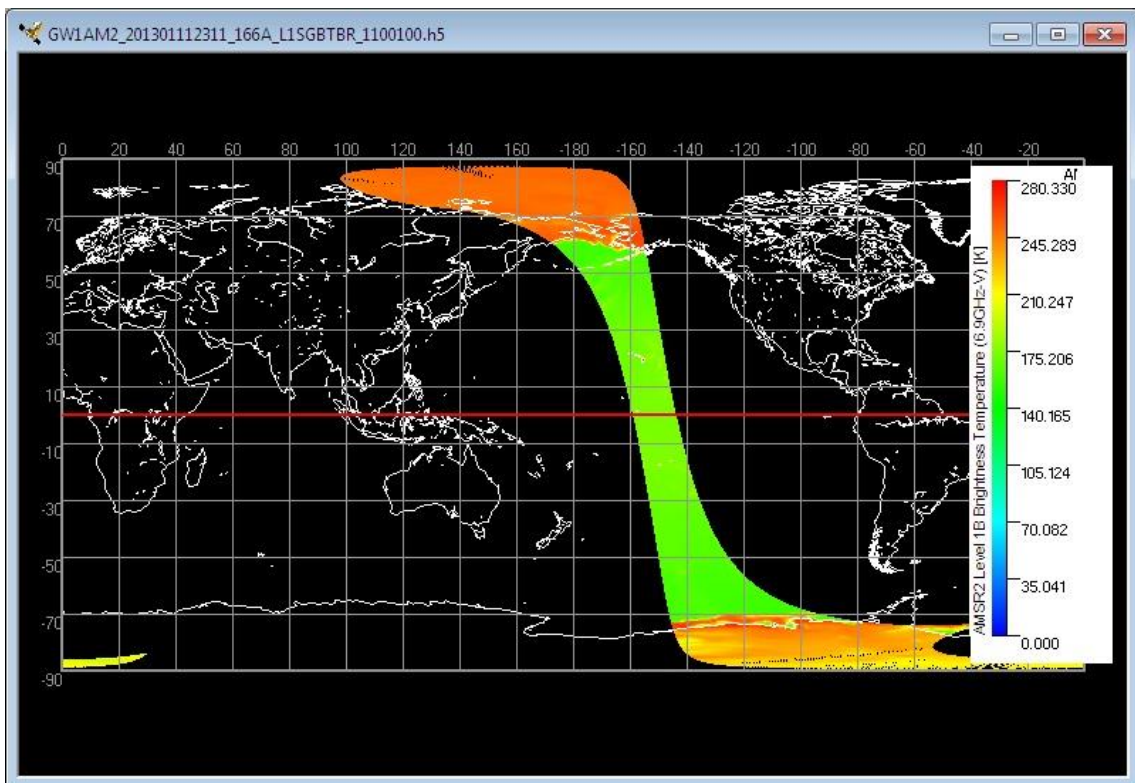

Fig. 4.2.6-1 Map display where color bar was vertically displayed

## 2) Horizontal

The color bar can be horizontally displayed.

Product/map display where the color bar was horizontally displayed is shown in Fig. 4.2.6 -2.

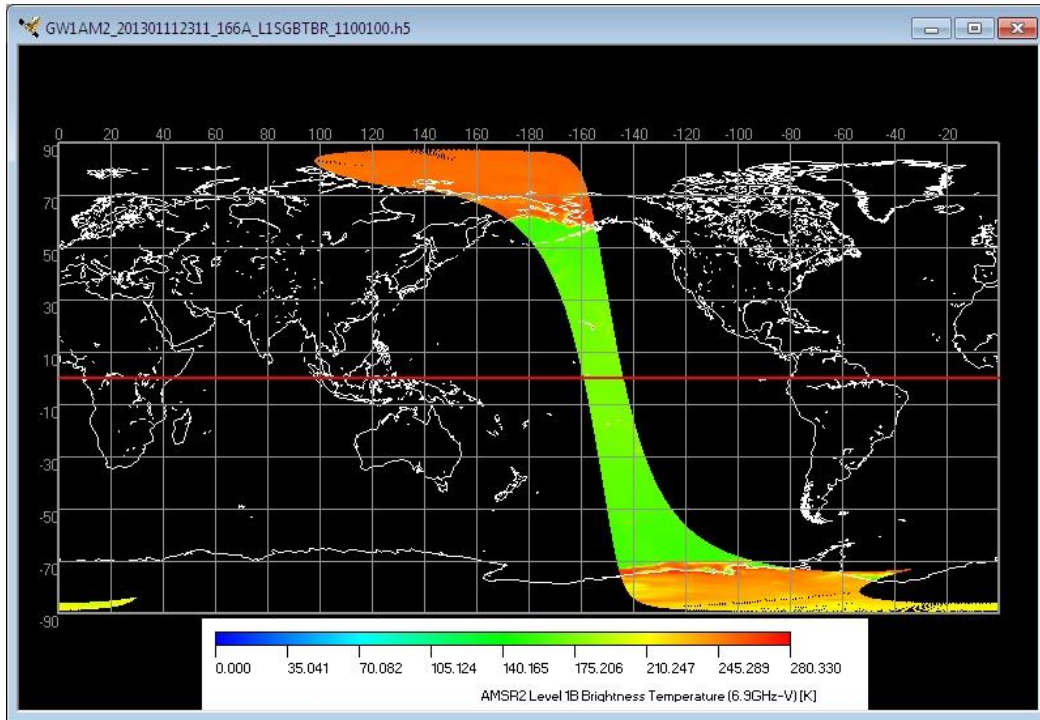

Fig. 4.2.6-2 Map display where color bar was horizontally displayed

### 4.2.7. ZOOM Mode

You can zoom in specified area on a map by specifying the area with the mouse.. When this mode is selected, the icon of the tool bar shown in Fig. 4.2.7-1 will be selected.

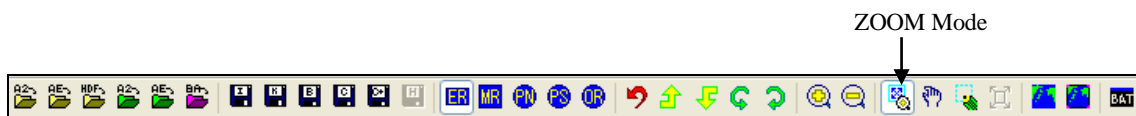

Fig. 4.2.7-1 [Zoom Mode] menu and Tool Bar

The Zoom method using the mouse drags to the specified end position the mouse while pushing the left mouse button at the specified beginning position, and separates the left mouse button at the specified end position.

If an area is specified, an area definition rectangle as shown in Fig. 4.2.7-2 will be displayed, and an image will be expanded automatically.



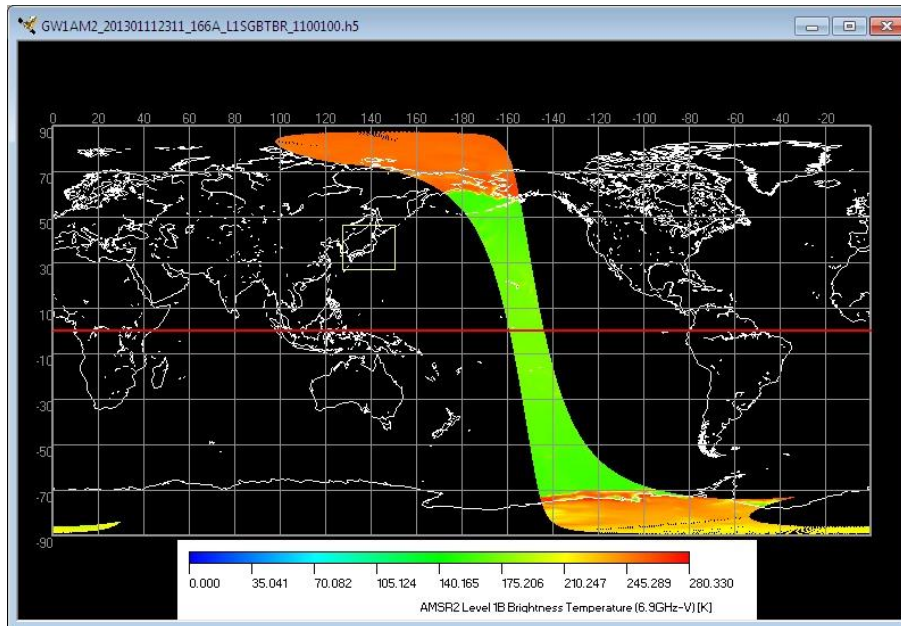

Fig. 4.2.7-2 Specified area on a map

Zoom In

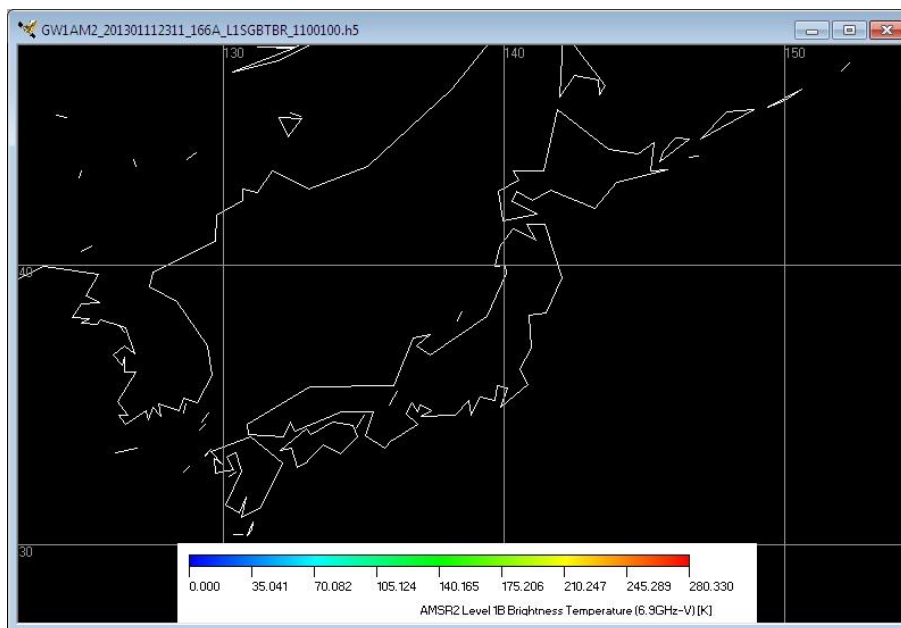

Fig. 4.2.7-3 Zoom In Picture

#### 4.2.8. PAN Mode

Map is movable vertically and horizontally with a mouse. When this mode is chosen, the icon of the tool bar shown in Fig. 4.2.8-1 will be selected.



Fig. 4.2.8-1 [PAN Mode] menu and Tool Bar

Map can be moved in using the mouse vertically or horizontally while a mouse is pushed the left mouse button on the map.

A mouse pointer becomes the form of a "hand" when this mode is chosen.

#### 4.2.9. SELECT Mode

The area can be specified by mouse. The specified area can be saved to a file as specified format (Image/KML/Binary/CSV). When this mode is chosen, the icon of the tool bar shown in Fig. 4.2.9-1 will be selected.



Fig. 4.2.9-1 [SELECT Mode] menu and Tool Bar

The SELECT method using the mouse drags to the specified end position the mouse while pushing the left mouse button at the specified beginning position, and separates the left mouse button at the specified end position.

If an area is specified, an area definition rectangle as shown in Fig. 4.2.9-2 will be displayed.

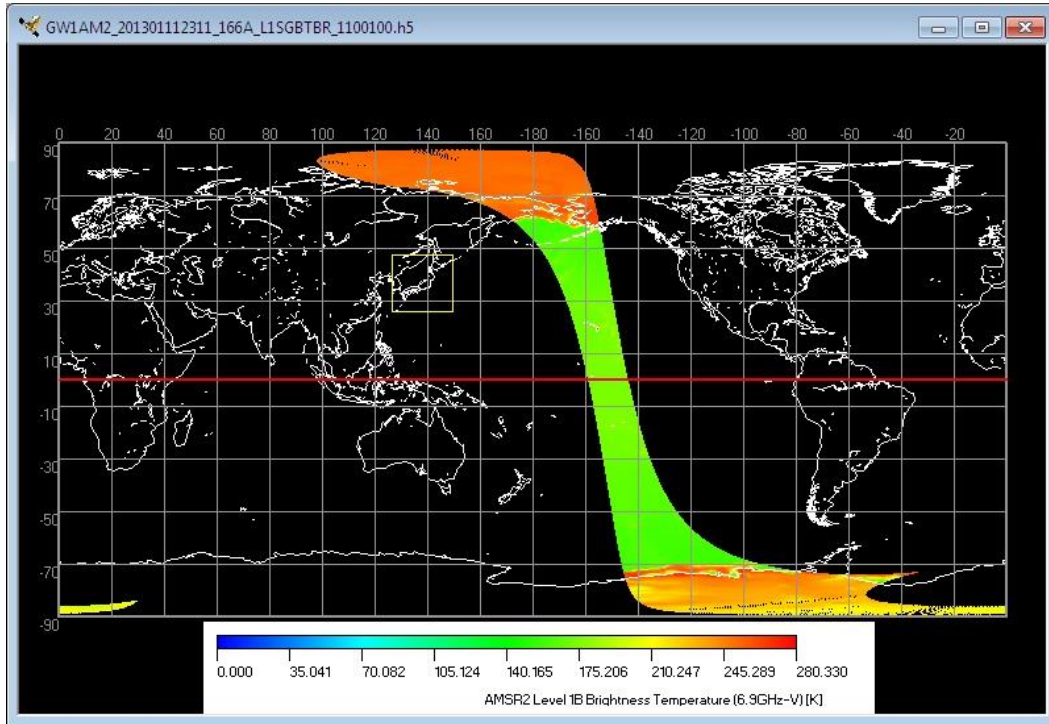

Fig. 4.2.9-2 Area Clip

#### 4.2.10. Select Area

[Selection Area Dialog] is displayed and a selection domain can be specified at latitude and longitude. When this mode is chosen, the icon of the tool bar shown in Fig. 4.2.10-1 will be chosen.

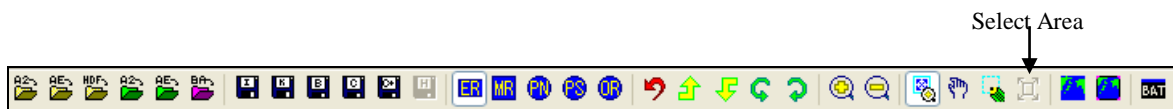

Fig. 4.2.10-1 [Map Selection Area] menu and Tool Bar

The specified domain can be outputted to a file in the specified format (Image/KML/Binary/CSV).

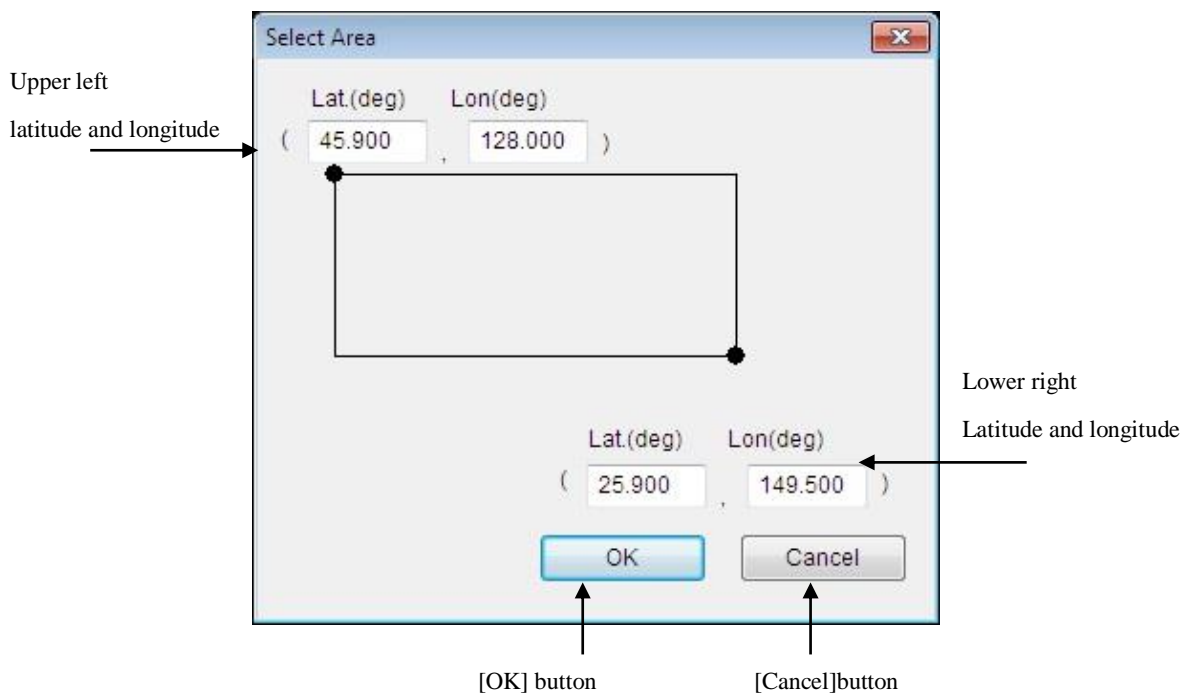

Fig. 4.2.10-2 Selection Area Dialog

■ [Upper left latitude and longitude]

- ① The latitude and longitude on the upper left within the range of specification is input. The unit is degree.

■ [Lower right latitude and longitude]

- ① The latitude and longitude on the lower right within the range of specification is input. The unit is degree.

■ [OK] button

- ① Click this [OK] button, displays an area definition rectangle as shown in Fig. 4.2.10-3.

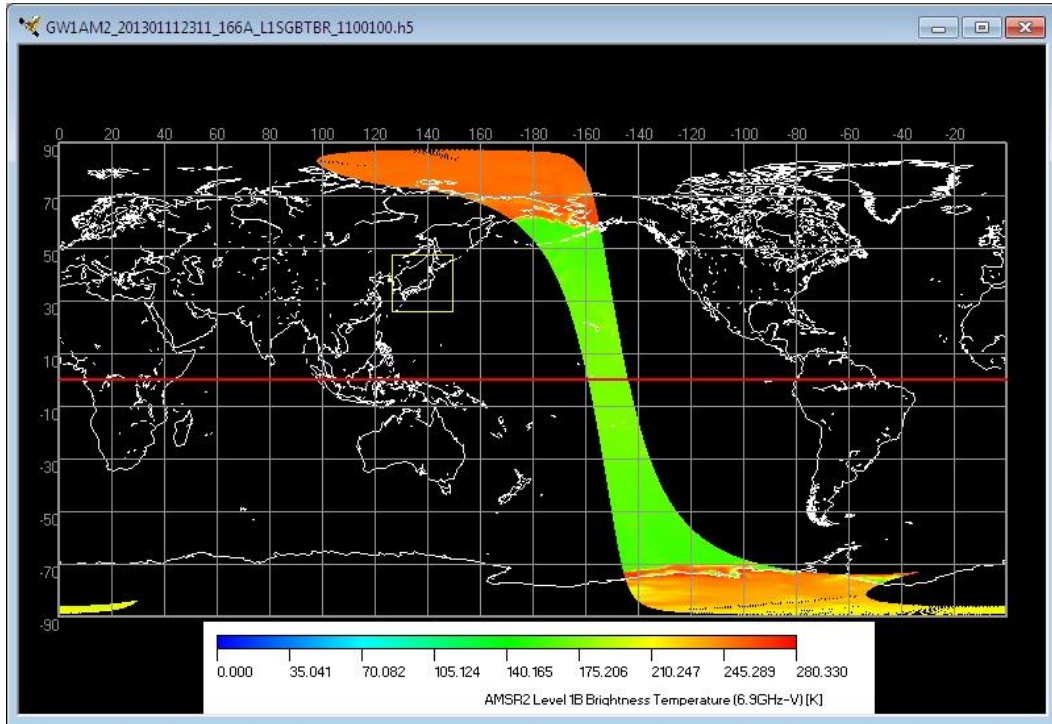

Fig. 4.2.10-3 Domain Clip

■ [Cancel] button

- ① Click this [OK] button
- ② All setting shown in the dialog are canceled and the dialog is closed.

**4.2.11. Batch Command History**

The operation record for the batch processing can be displayed.

Batch Command History Dialog as shown in Fig. 4.2.11-2 will be displayed,

When this mode is chosen, the icon of the tool bar shown in Fig. 4.2.11-1 will be chosen.

Batch Command History



Fig. 4.2.11-1 [Batch Command History] Tool Bar

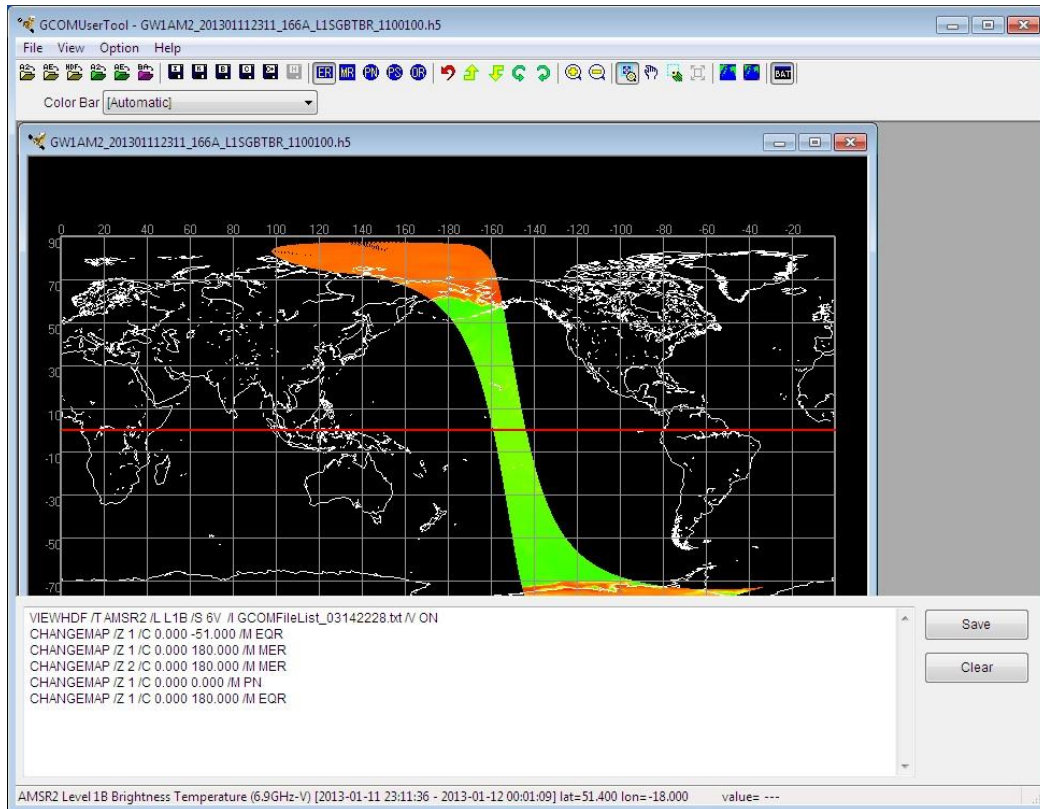

Fig. 4.2.11-2 Batch Command History Dialog

■ [Save] button

- ① The dialog that preserves the content displayed in the batch command history in the batch file is displayed.

■ [Clear] button

- ① Click this [OK] button
- ② The content displayed in the batch command history is cleared.

### 4.3. Option Menu

There are six subsidiary menus in the option menu.

- (1) Edit Color Bar Table
- (2) Edit Look Up Table
- (3) User Setting
- (4) Image Output option
- (5) Map Layer
- (6) Map File Setting

A file menu is shown in Fig. 4.3-1, and each menu is explained henceforth.

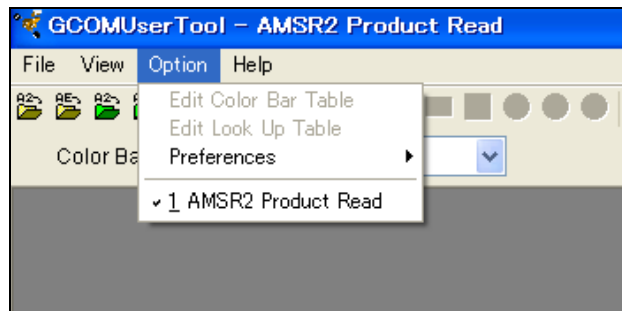

Fig. 4.3-1 Option Menu Pull Down

### 4.3.1. Edit Color Bar Table

When [Edit Color Bar Table] menu is selected, [Color Bar Table Edit Dialog] is displayed and new creation and setting change of a color bar table can be made. [Color Bar Table Edit Dialog] is shown in Fig. 4.3.1-1. When the “Single channel” image is displayed, this menu is active.

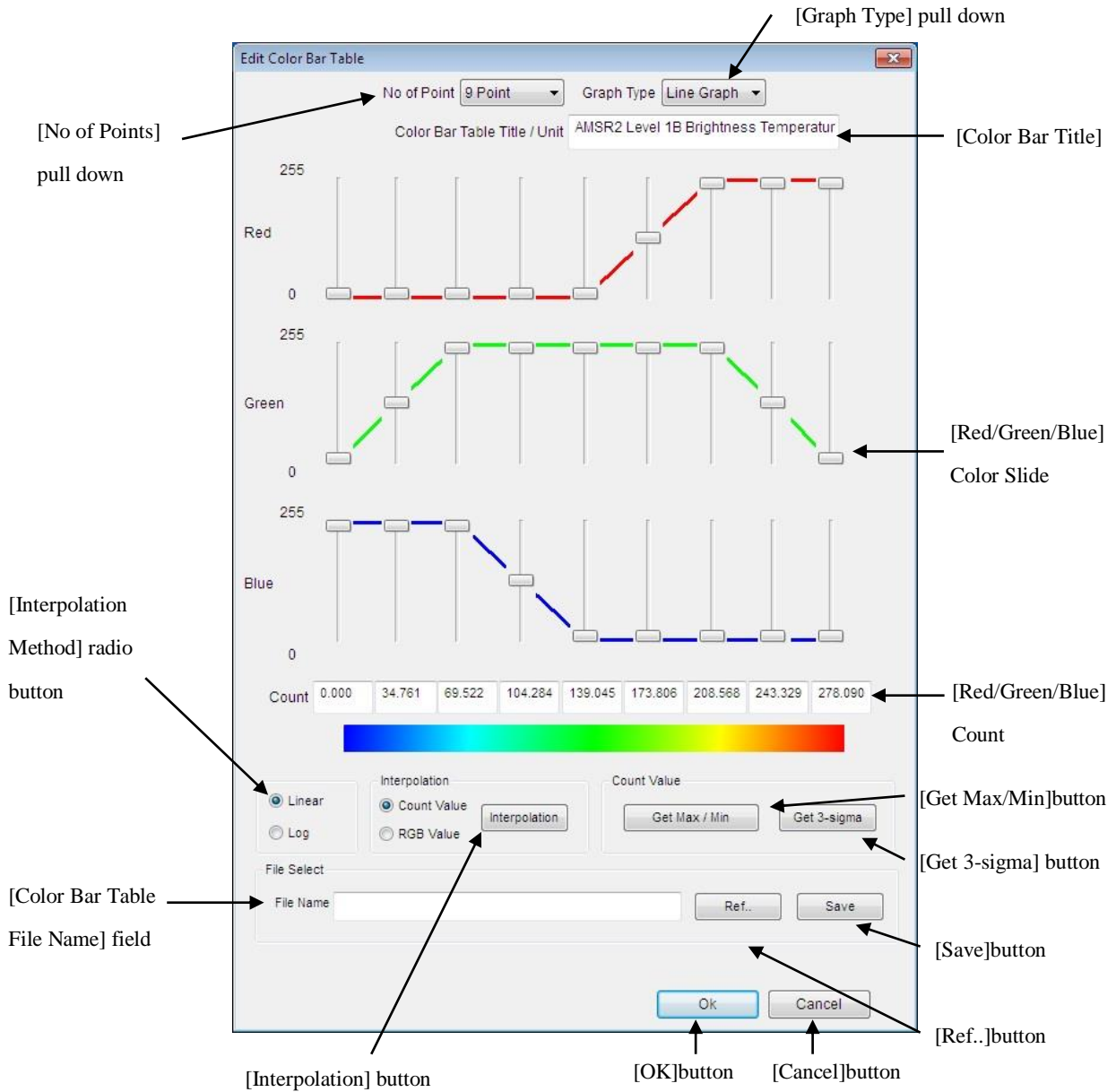

Fig. 4.3.1-1 Color Bar Table Edit Dialog



■ **[No. of Points]** pull down

The number of reference points for count value and color pallet is selected.

There is the following four kinds of points of this pull down menus.

- ① 2 points
- ② 3 points
- ③ 5 points
- ④ 9 points

■ **[Graph Type]** pull down

The graph type of the edit color bar table is selected from this pull-down menu.

There is the following two kinds of graph type of this pull down menus.

- ① Line Graph
- ② Bar Graph

■ **[Color Bar Table Title]**

- ① The title of a color bar table can be specified.

■ **Color Slide**

- ① The color specified in each point element (red, green and blue) is displayed in the graph. The color of each point can be changed by changing the slide.

■ **[Count]** (Data value input fields)

- ① The counter value for each reference point is input. Please specify the count value for both edge fields at least. **[Get Max/Min]** and **[Get 3-sigma]** button will help you to get the range of the image data into the fields.

■ **Color table image display column**

- ① The image of the color table set now is displayed.

■ **[Linear/Log]** radio button

- ① The display method of the color table is set to linear/logarithm display.

■ **[Interpolation]** button

- ① This button is clicked.
- ② The count fields except both edges are calculated by the linear or logarithm interpolation.

■ **[Get Max/Min]** button

- ① This button is clicked.
- ② The maximum and minimum count value of the image data and stores them into count fields .

■ **[Get 3-sigma]** button

- ① This button is clicked.
- ②  $3\sigma$  value of the image data is acquired and the value is set to the point at both ends.

■ **[File Name]** field

- ① The edited color bar table file name is displayed.

■ **[Ref..]** button

- ① This button is clicked.
- ② **[Open]** dialog layout is shown in Fig. 4.3.1-4.
- ③ The edited color bar table file name is specified.

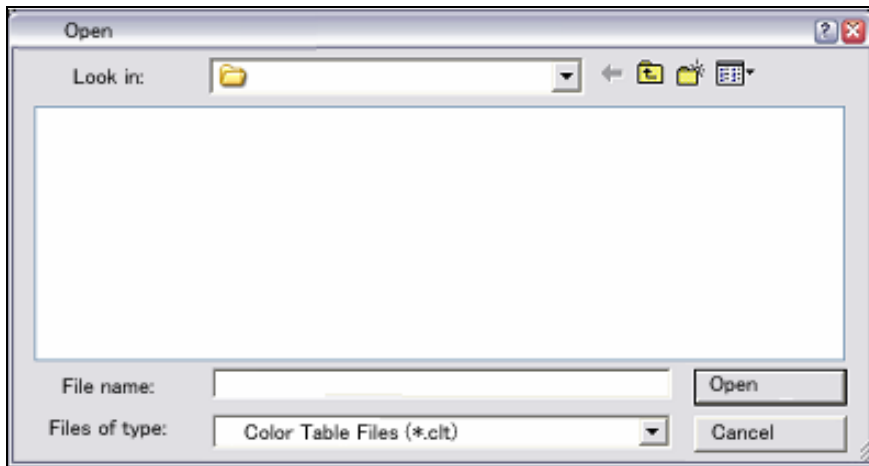

Fig. 4.3.1-4 [Open] dialog

■ **[Save]** button

- ① This button is clicked.
- ② **[Save As]** dialog layout is shown in Fig. 4.3.1-5.
- ③ The color table file name in which the edit result is saved is specified.
- ④ The extension of the save file is 'clt'.

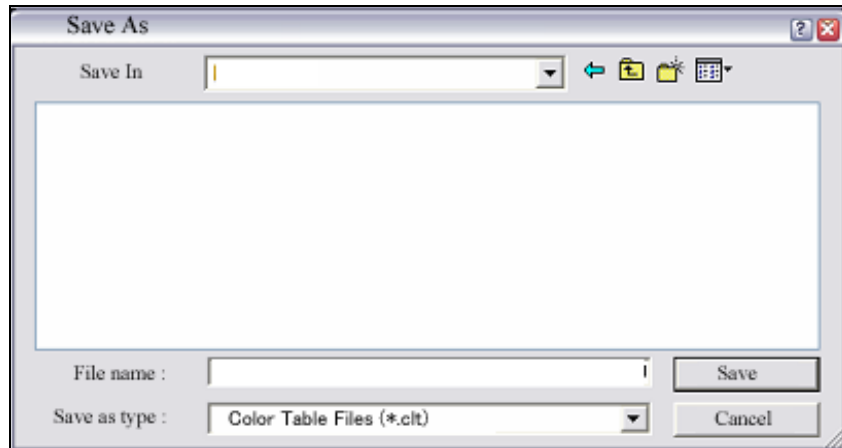

Fig. 4.3.1-5 [Save As] dialog

■ **[OK]** button

- ① This button is clicked.
- ② The currently specified Color Bar Tables applied to the data shown in the image window and the dialog is dismissed.

■ **[Cancel]** button

- ① This button is clicked.
- ② All settings shown in the dialog are canceled and the dialog is dismissed

### 4.3.2. Edit Look Up Table

When [Edit Look Up Table] menu is selected, [Look Up Table Edit Dialog] can display and new creation and setting change of a color bar table can be made. [Look Up Table Edit Dialog] is shown in Fig. 4.3.2-1.

Only in the case of a "RGB composite" picture, this menu can choose.

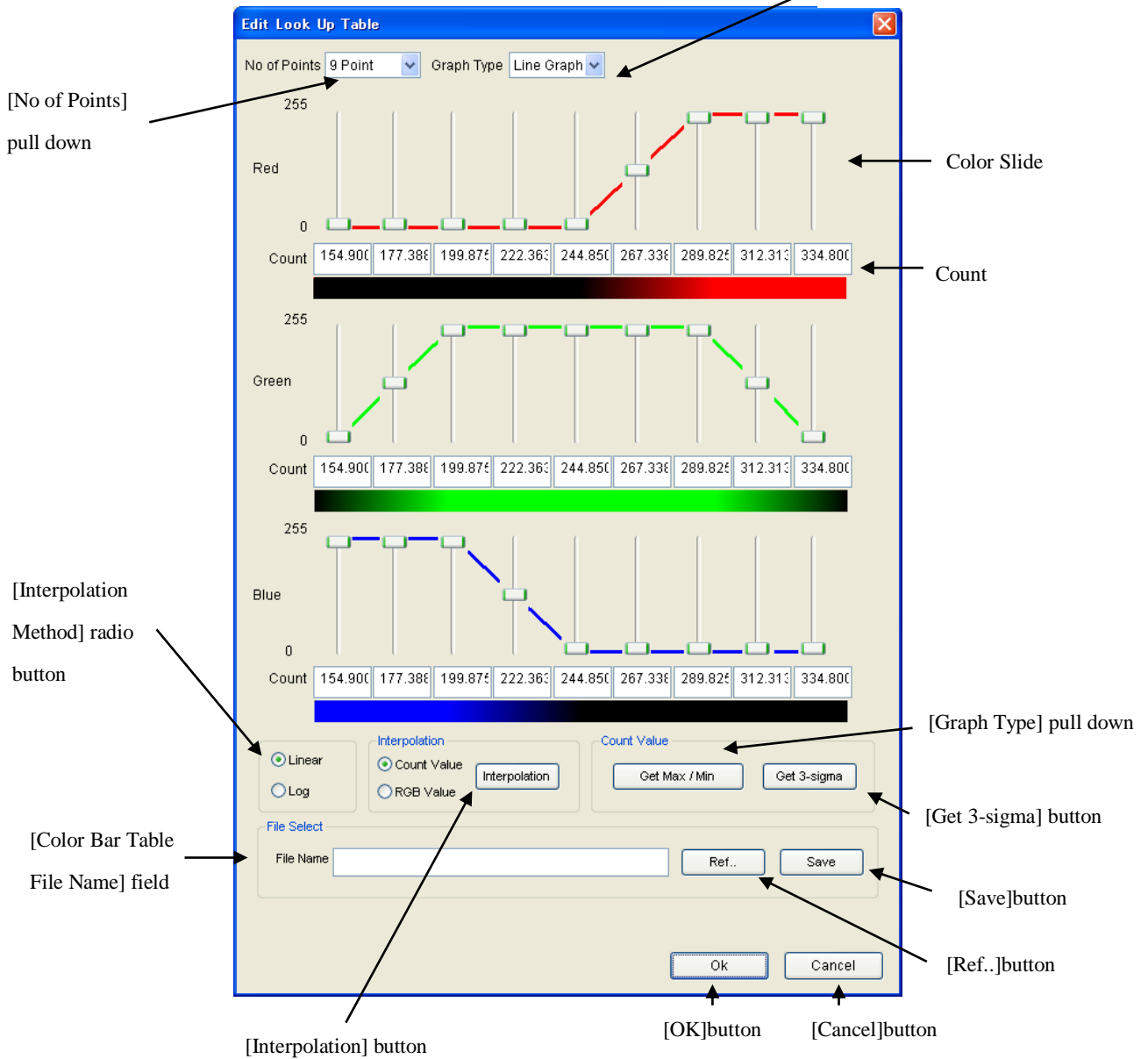

Fig. 4.3.2-1 Look Up Table Edit Dialog

■ **[No. of Points]** pull down

The number of reference points for count value and color pallet is selected.

There are the following four kinds of points of this pull down menus.

- ① 2 points
- ② 3 points
- ③ 5 points
- ④ 9 points

■ **[Graph Type]** pull down

The graph type of the edit color bar table is selected from this pull-down menu.

There are the following two kinds of graph type of this pull down menus.

- ① Line Graph
- ② Bar Graph

■ **Red/Green/Blue Color Slide**

- ① The color specified in each point element (red, green and blue) is displayed in the graph. The color of each point (0~255) can be changed by changing the slide.

■ **[Red/Green/Blue Count]** fields

- ① The image data value corresponding to RGB of the point is input.  
Please specify the count value for both edge fields at least. **[Get Max/Min]** and **[Get 3-sigma]** button will help you to get the range of the image data into the fields.

■ **Red/Green/Blue Count**

- ① Color (0~255) is specified for each Red/Green/Blue.

■ **[Linear/Log]** radio button

- ① The display method of the color table is set to linear/logarithm display.

■ **[Interpolation]** button

- ① This button is clicked.
- ② The count fields except both edges are calculated by the linear or logarithm interpolation.

■ **[Get Max/Min]** button

- ① This button is clicked.
- ② The maximum and minimum count value of the image data and stores them into count fields .

■ **[File Name]** field

- ① The edited color bar table file name is displayed.

■ **[Ref.]** button

- ① This button is clicked.
- ② **[Open]** dialog layout is shown in Fig. 4.3.2 -2.
- ③ The edited color bar table file name is specified.

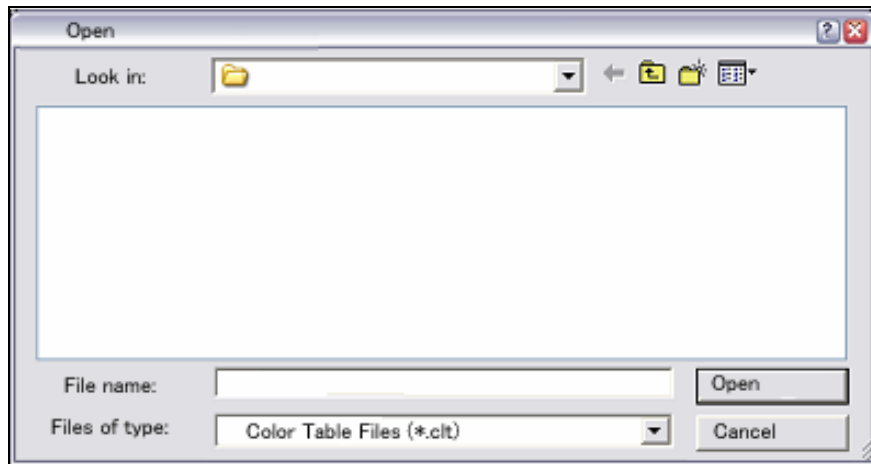

Fig. 4.3.2-2 [Open] dialog

■ **[Save]** button

- ① This button is clicked.
- ② **[Save As]** dialog layout is shown in Fig. 4.3.2-3.
- ③ The Look Up table file name in which the edit result is saved is specified.
- ④ The extension of the save file is ' lut '.

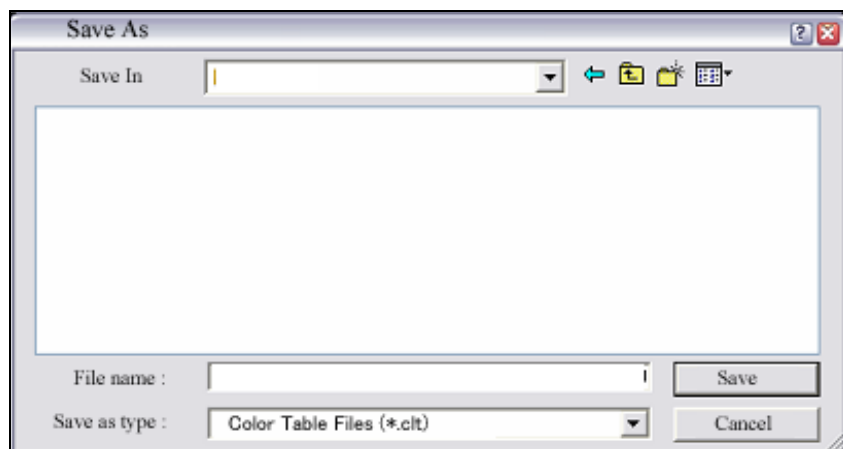

Fig. 4.3.2-3 [Save As] dialog

■ **[Preview]** button

- ① This button is clicked.
- ② The image processed with the edited look up table is displayed.

■ **[OK]** button

- ① This button is clicked.
- ② The currently specified Look Up Table applied to the data shown in the image window and the dialog is dismissed.

■ **[Cancel]** button

- ① This button is clicked.
- ② All settings shown in the dialog are canceled and the dialog is dismissed

### 4.3.3. User Setting

The display setting of this user tool can be done.

When this menu is selected, **[User Setting Dialog]** is shown in Fig. 4.3.3-1.

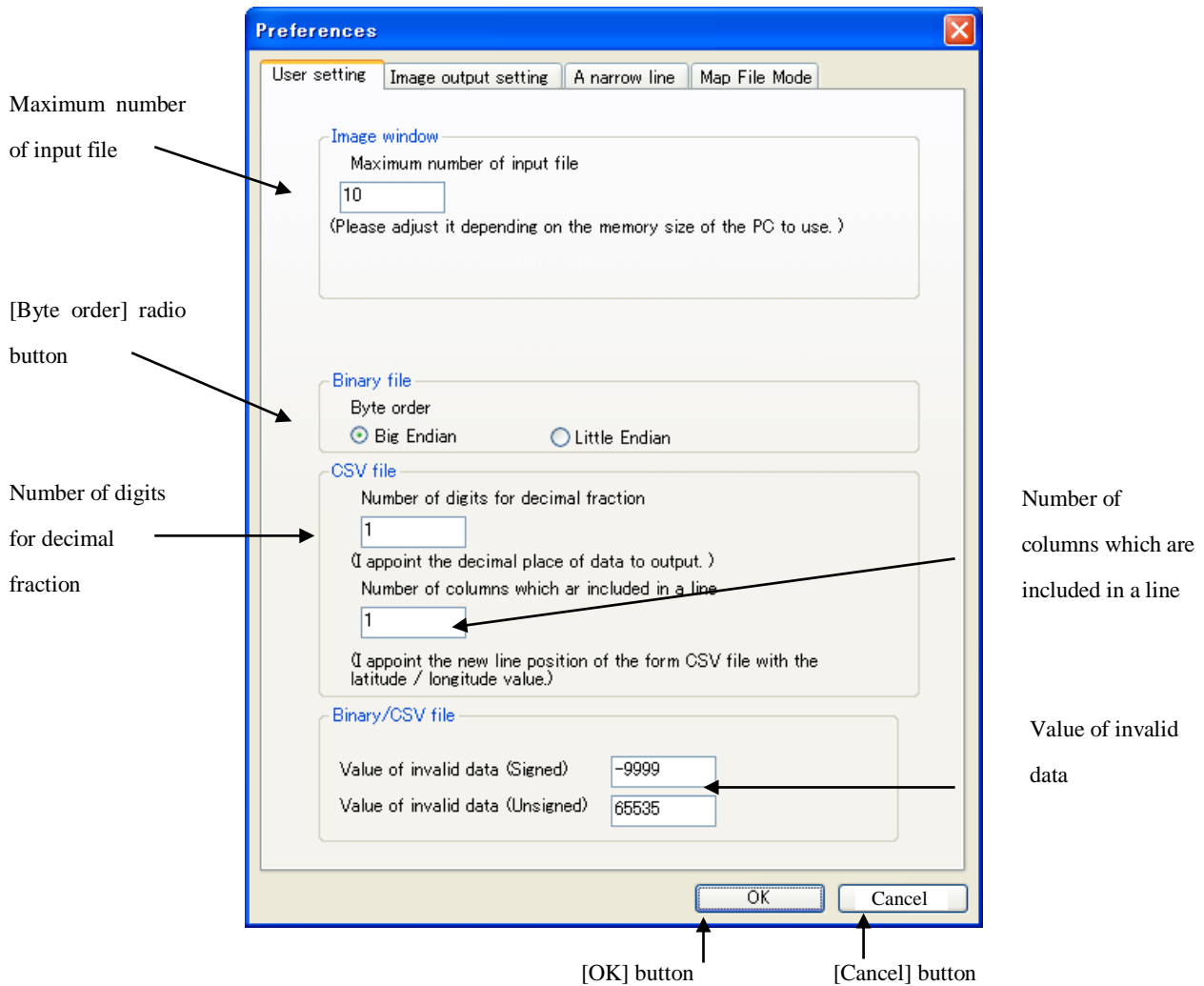

Fig. 4.3.3-1 Image User Setting Dialog

■ Maximum number of input file

- ① The number of readable at the same time products is specified.

■ [Byte order] radio button

- ① Byte order of the data output by the binary form is selected from "Big endian" or "Little endian".

■ Number of digits for decimal fraction

- ① The digit number below the decimal point of the data output to the CSV file is specified.

■ Number of columns which are included in a line

- ① The point stored on one record of the CSV file is specified.



■ Value of invalid data

- ① When saving it by the binary form and Comma Separated Value, the value set to the unmapped region is specified.

#### 4.3.4. Image Output option

When [Image Output option] menu is selected, [Image Output Setting Dialog] can be displayed and the layout when saving as a Image (TIFF/JPEG/PNG/BMP format) can be set up. [Image Output Setting Dialog] is shown in Fig. 4.3. 4-1.

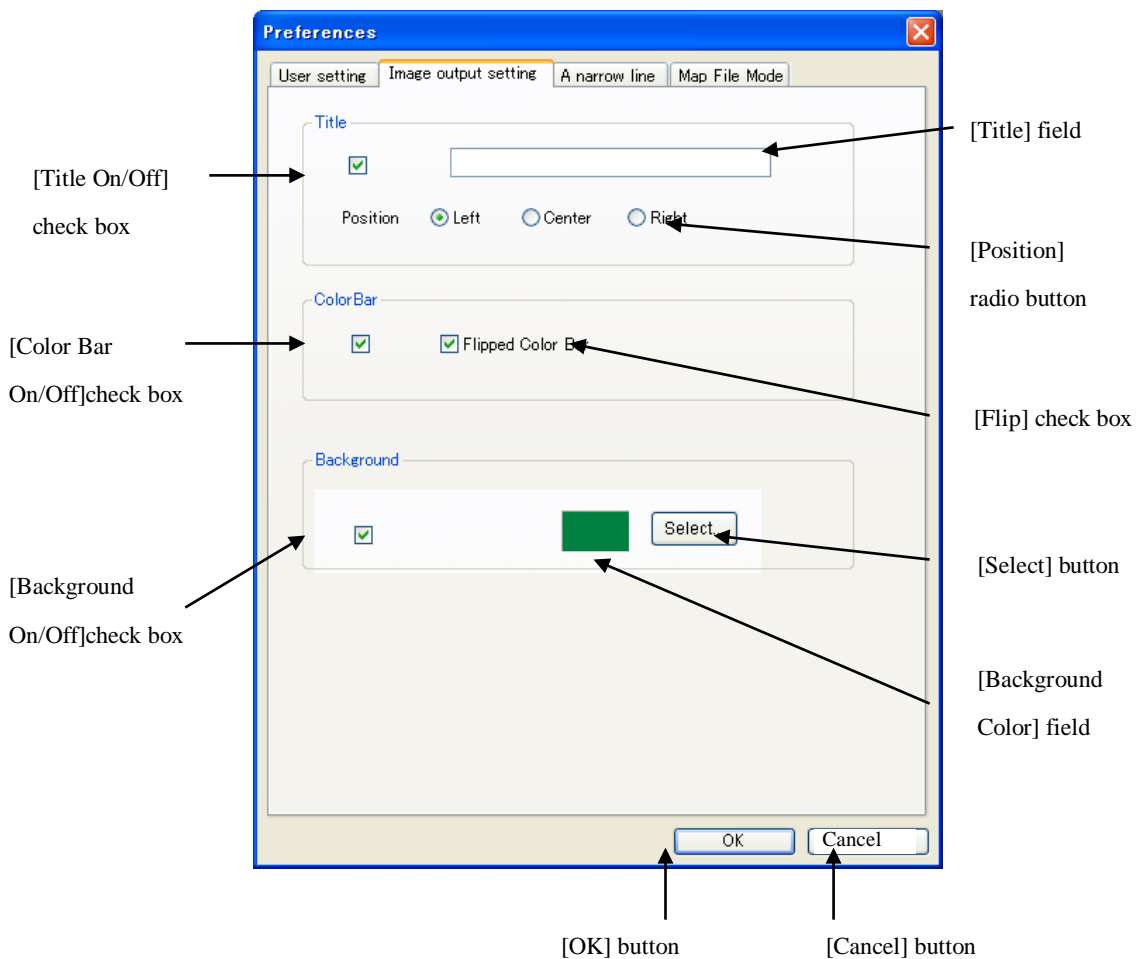

Fig. 4.3.4-1 Image Output Setting Dialog

Difference of image output setting screen by Fig. 4.3. 4-2 Single Channel and RGB Composite.

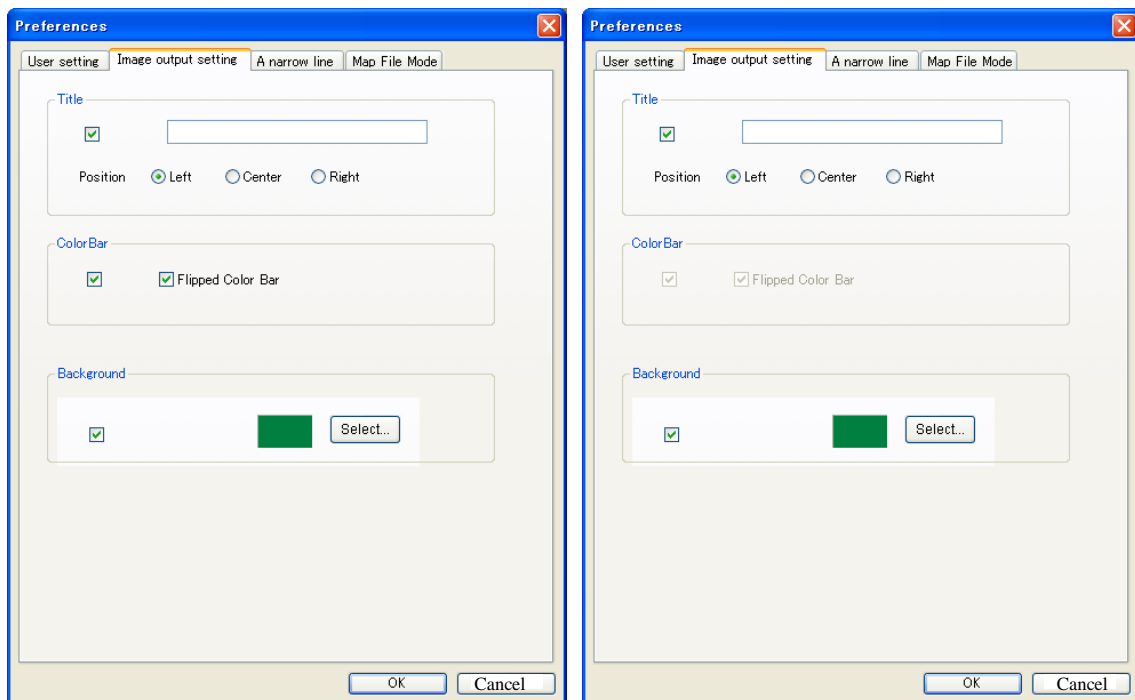

Fig. 4.3.4-2 The difference in a dialog

- **[Title On/Off]** check box

- ① The presence of the title is specified.

- **[Title]** field

- ① The title of the image is input. When this item is specified, the title is displayed on **[Image Window]** dialog.

Only when **[Title On/Off]** check box is on, it is possible to set it.

■ **[Position]** radio button

① The position where the title is displayed is specified from the following three options.

Only when **[Position]** radio button is checked, it is possible to set it.

**[left]**

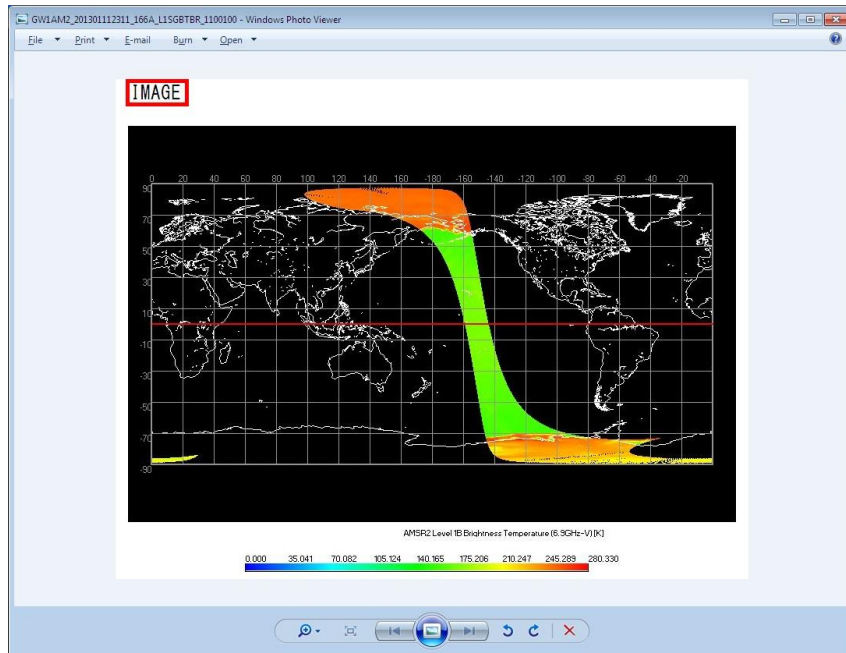

Fig. 4.3.4-3 Image sample of the title position “left”

**[center]**

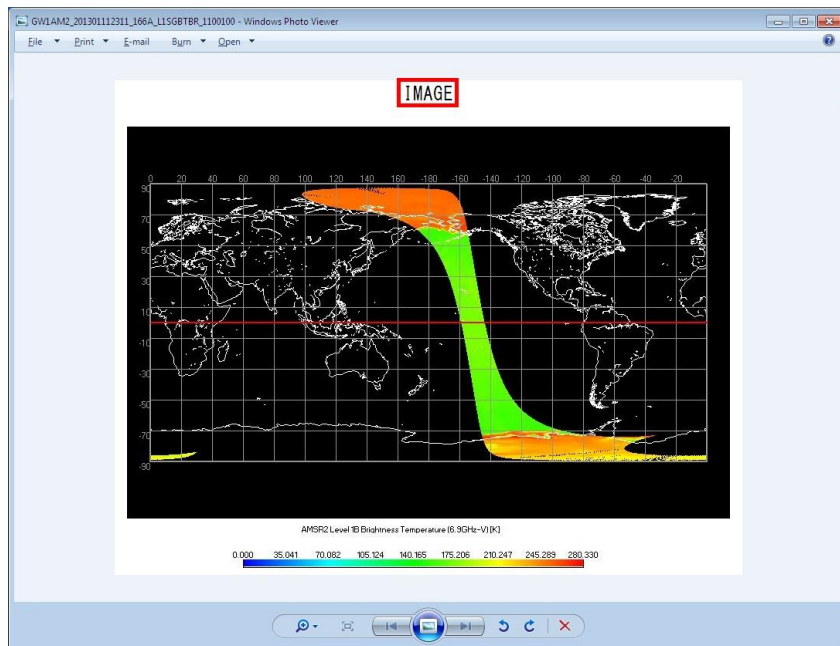

Fig. 4.3.4-4 Image sample of the title position “center”

[right]

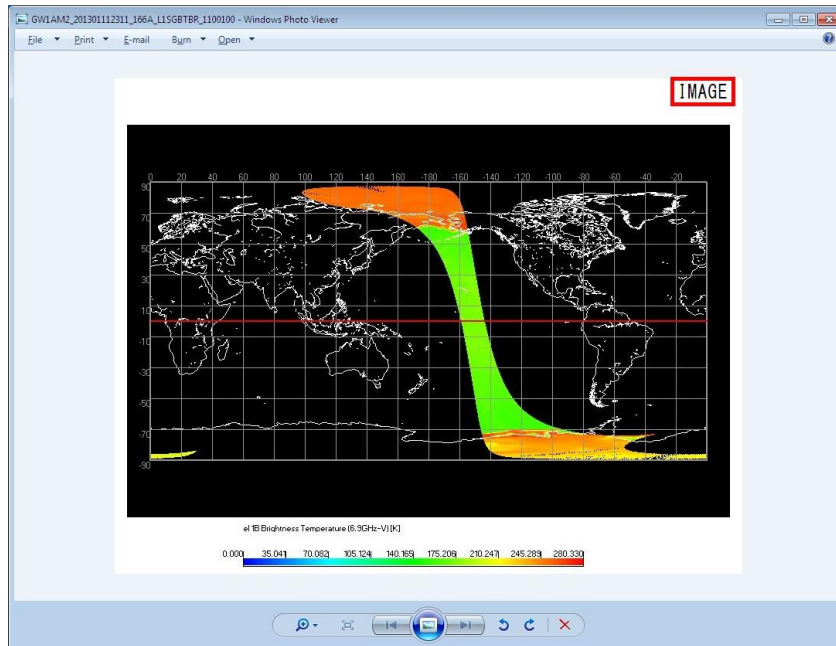

Fig. 4.3.4-5 Image sample of the title position “right”

■ [Color Bar On / Off] Check box

① The presence of the color bar is specified.

Only for a single channel, the presence of the Color Bar is specified.

This function also reflects the Color Bar on the image window.

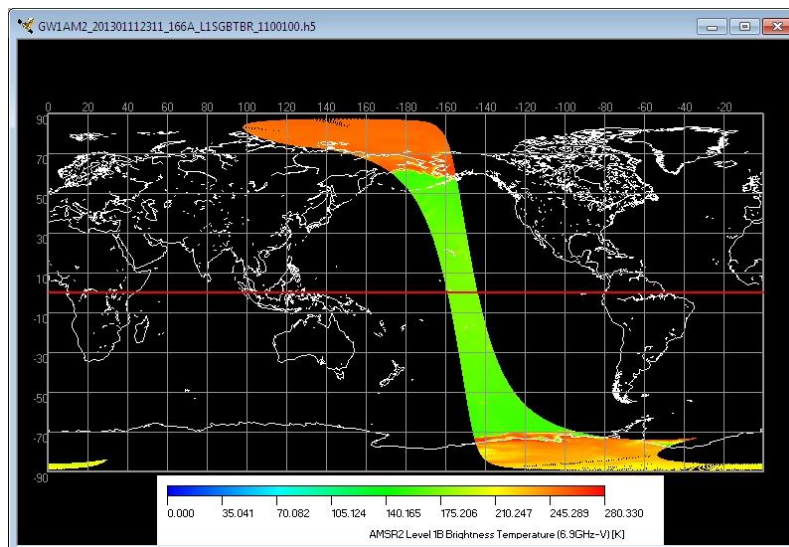

Fig. 4.3.4-6 Image window with a Color Bar

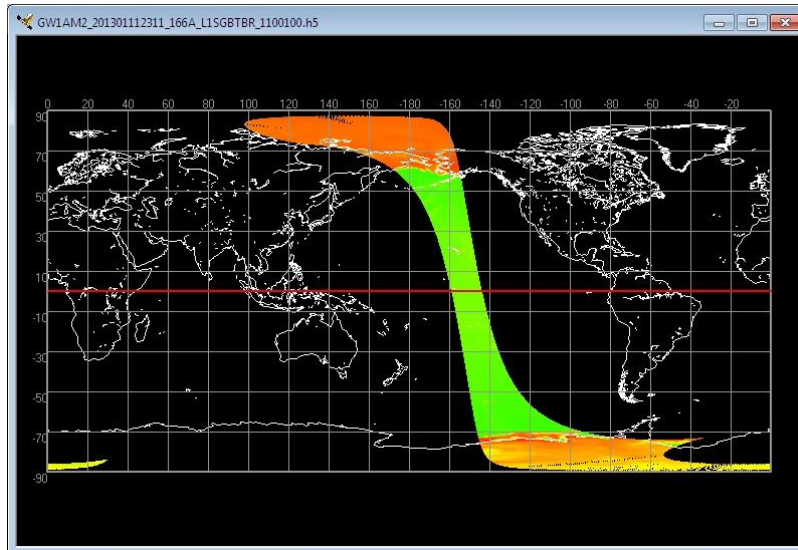

Fig. 4.3.4-7 Image the window without a Color Bar

■ **[Flip]** check box

① The Color Bar can be flipped.

Only for a single channel, if you mark **[Flip]** check box on the dialog.

**[Un-choosing]**

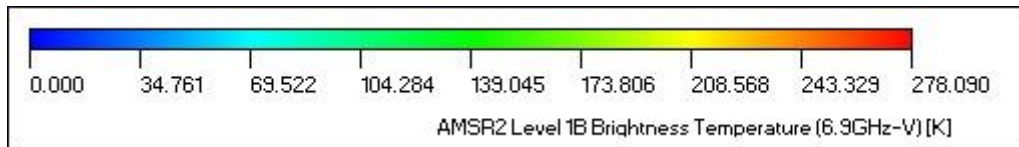

Small  $\longrightarrow$  Big

Fig. 4.3.4-8 Sample of a not flipped color bar

**[Choosing]**

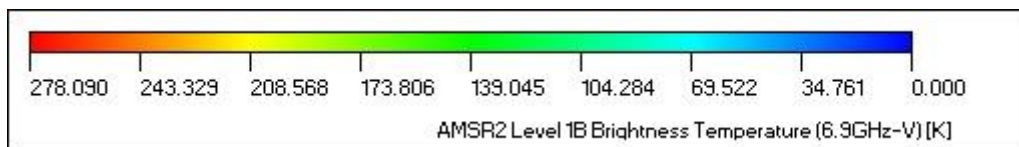

Big  $\longrightarrow$  Small

Fig. 4.3.4-9 Sample of a flipped color bar

■ [Background On/Off] check box

- ① The color of background is displayed is specified.

[Choosing]

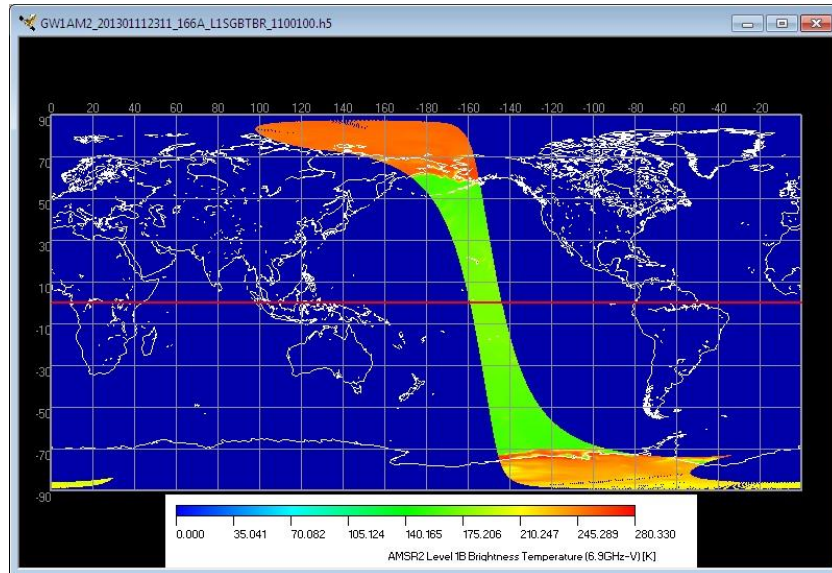

Fig. 4.3.4-10 Image sample with background color changed

[Un-choosing]

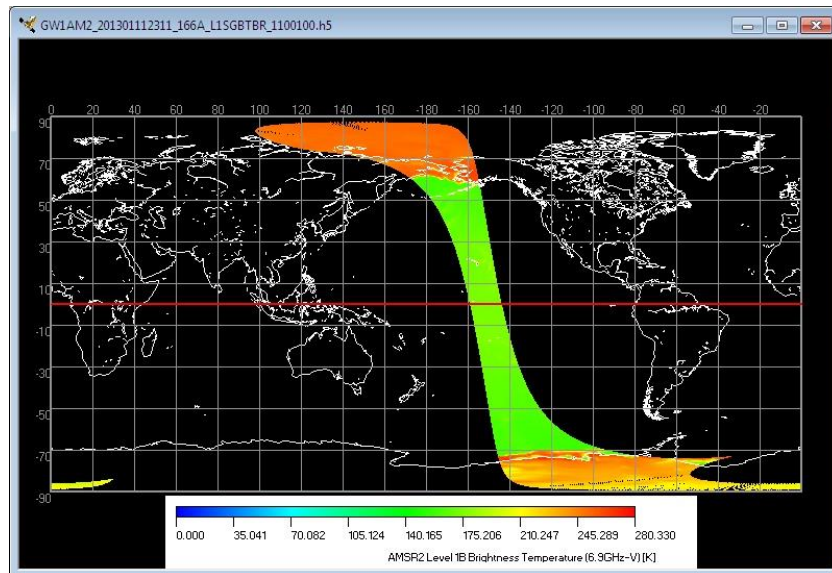

Fig. 4.3.4-11 Image sample with background color not changed

■ [Background Color] field

- ① The color that has been selected as background color is displayed.

■ **[Select]** button

- ① This button is clicked.
- ② The [color] dialog is displayed, and you can select the color assignment of the background.

■ **[OK]** button

- ① This button is clicked.
- ② The image output setting is saved and 'Image output setting dialog is dismissed.

■ **[Cancel]** button

- ① This button is clicked.
- ② All setting shown in the dialog are canceled and the dialog is dismissed.

### 4.3.5. Map Layer

When [Map Layer] menu is selected, [Map layer Edit Dialog] can be displayed and you can select the drawing color of coastline, latitude and longitude lines and the equator for each image window. [Map layer Edit Dialog] is shown in Fig. 4.3.5-1.

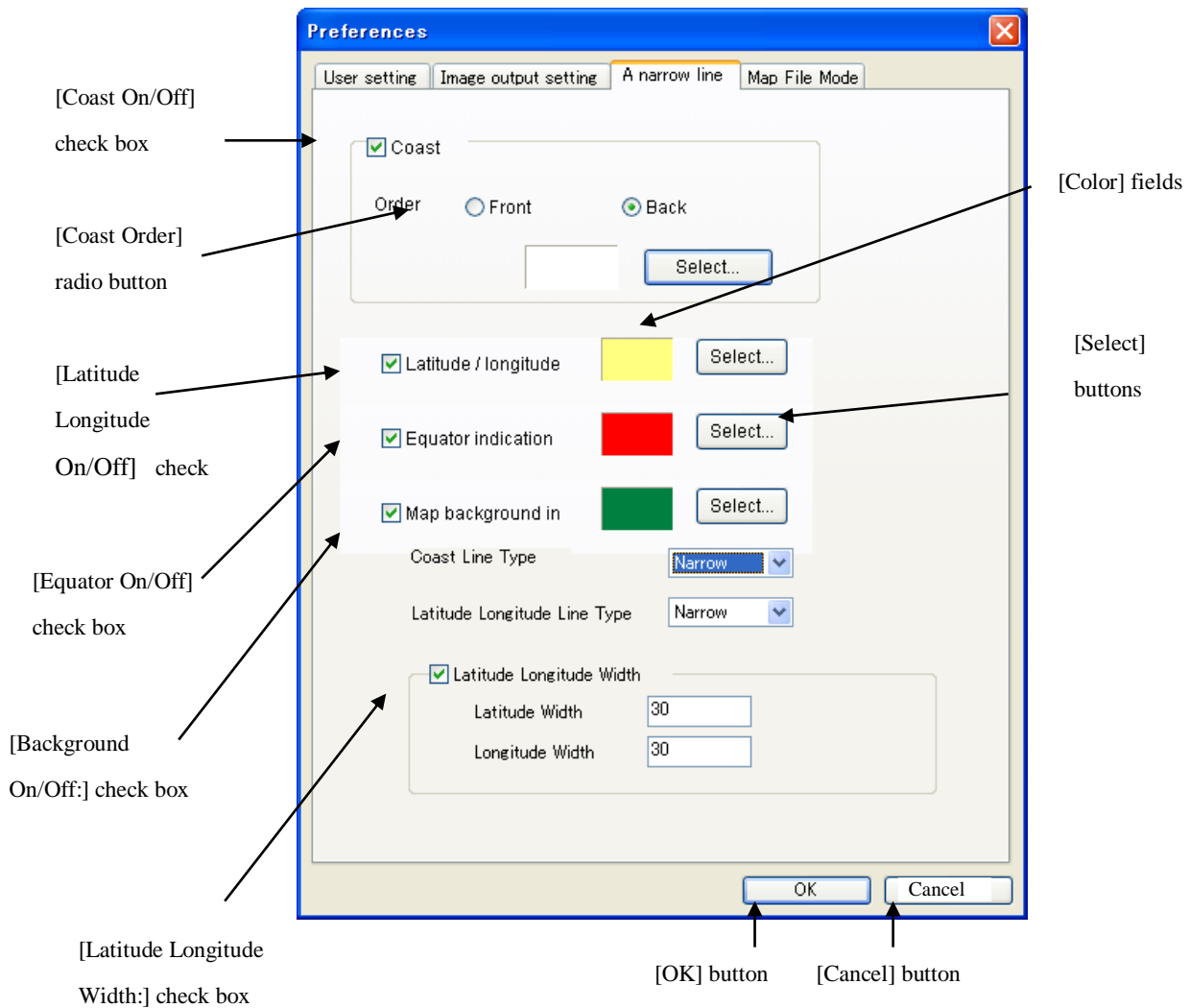

Fig. 4.3.5-1 Map layer Edit

- [Coast On/Off] check box

- ① The coastline are displayed on this window.

- [Coast Order] radio button

- ① You can specify which in front side/back of data to display the coastline.

[Front]

All coastlines are displayed



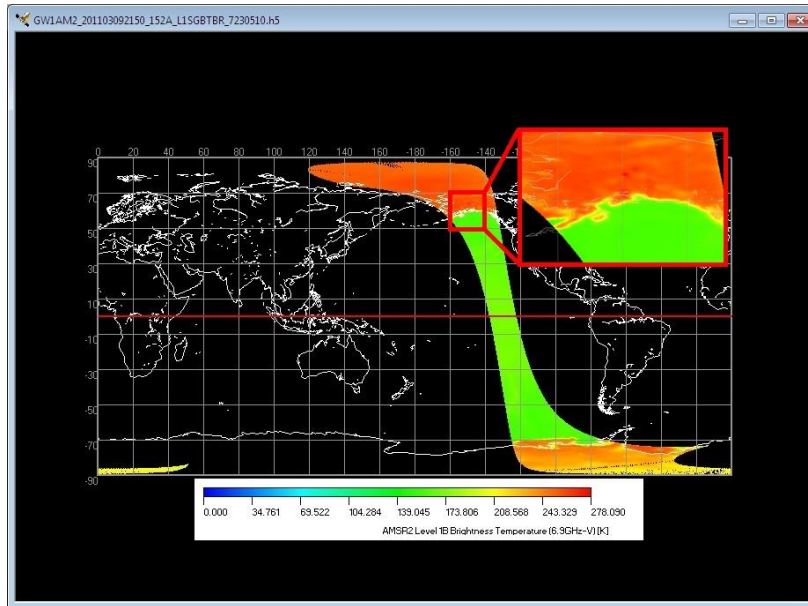

Fig. 4.3.5-2 Example of displaying the coastline on the front side of the data

[Back]

A part of the coastline is hidden by displayed data.

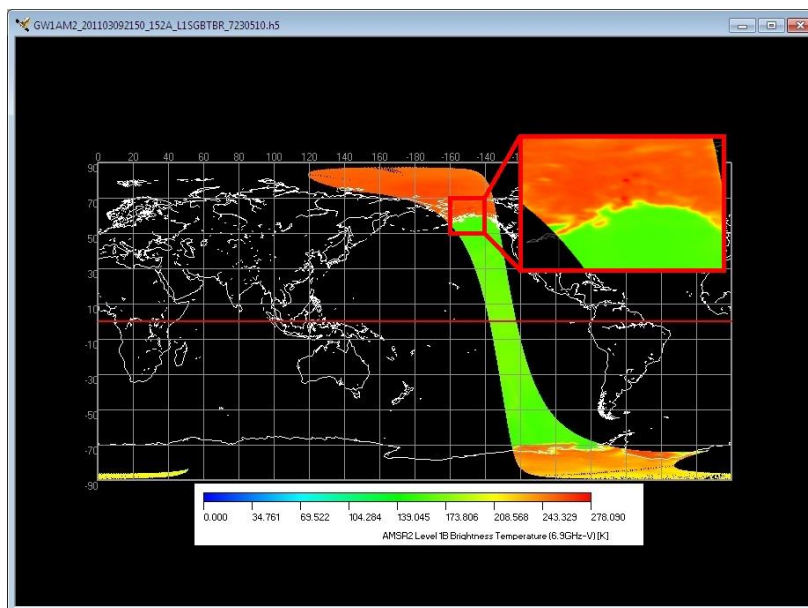

Fig. 4.3.5-3 Example of displaying the coastline on the back of the data

■ [Latitude and longitude On/Off] check box

① The latitude and longitude lines are displayed on this window.

■ [Equator On/Off] check box

① The equator lines are displayed on this window.

■ **[Background On/Off]** check box

- ① The background color is changed it to the selected color.

■ **[Select]** buttons

- ① This button is clicked.
- ② The [color] dialog is displayed, and you can select the color assignment of the background.

■ **[Color]** fields

- ① The color that has been selected is displayed.

■ **[Coast Line Type]** pull down

- ① The thickness in the coastline is selected from this pull down menu.  
There is the following three kinds of points of this pull down menus.

Narrow  
Middle  
Bold

■ **[Latitude and longitude Line Type]** pull down

- ① The thickness in the Latitude and longitude Line is selected from this pull down menu.

Narrow  
Middle  
Bold

■ **[Latitude and longitude Width]** check box

- ① Whether the interval in the latitude and longitude line is adjusted to a fixed value.

■ Latitude Width

- ① The interval in the latitude line is specified.

■ Longitude Width

- ① The interval in the longitude line is specified.

#### 4.3.6. Position Error Correction

The file setting in the displayed map can be changed.

[Map File Mode Dialog] is shown in Fig. 4.3.6-1.

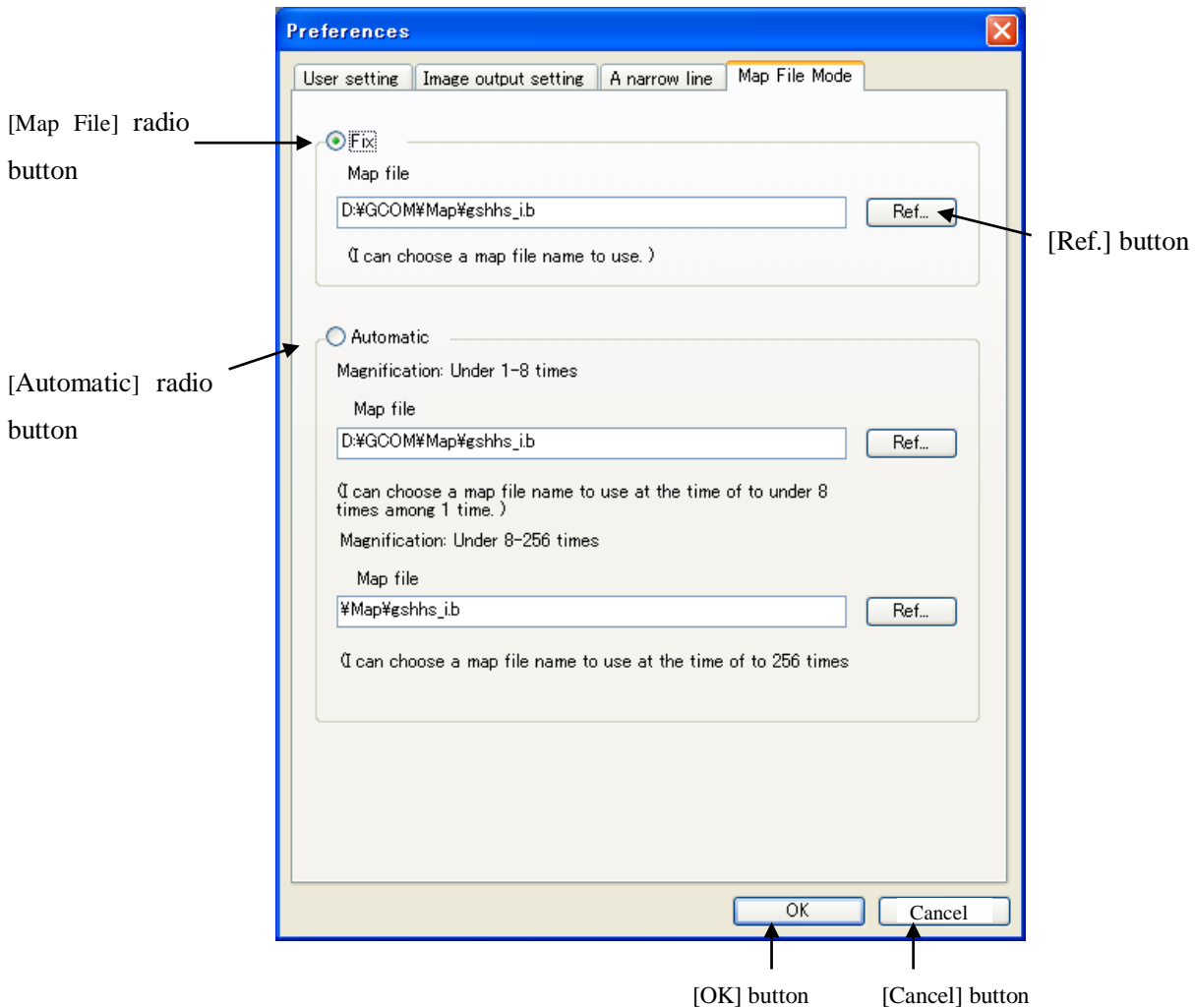

Fig. 4.3.6-1 Map File Mode

■ [Map File] radio button

- ① Please specify which display method fix/automatic operation to make the map file.

[Fix]

The coastline is displayed by using all the same one-map files regardless of the magnification.

[Automatic]

The magnification one time ~ Less than eight times and the magnifications are eight times~ 256 times file is switched and the coastline is displayed.

■ [Ref..] button

- ① This button is Clicked.
- ② 'File selection window' is displayed, and the map file is specified.

## 4.4. Help Menu

There are four subsidiary menus in an option menu.

- (1) Help
- (2) related link
- (3) Version Information

A file menu is shown in Fig. 4.4-1, and each menu is explained henceforth



Fig. 4.4-1 Help Menu Pull Down

### 4.4.1. Help

When [**Help**] menu is selected, a help is displayed on a Browser. Help window format is shown in Fig. 4.4-2.

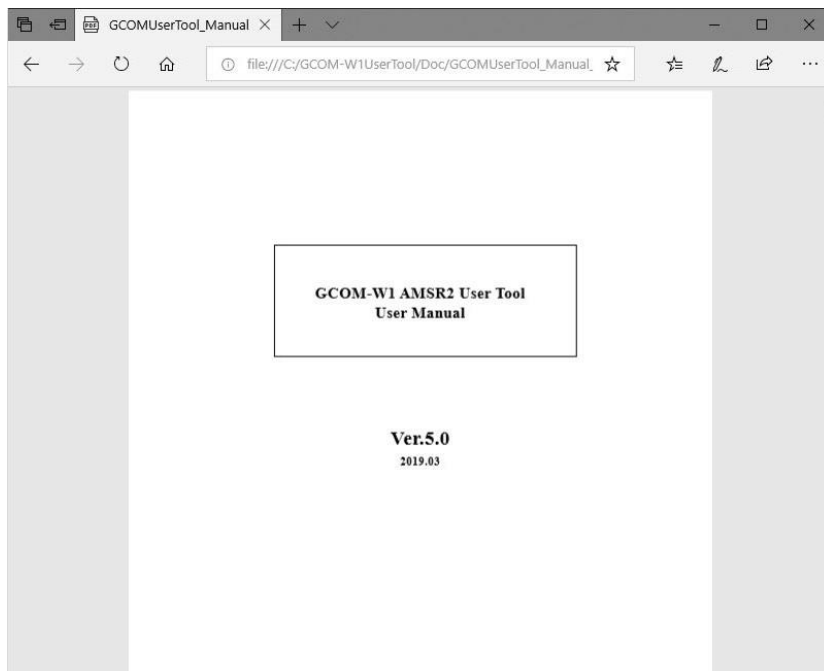

Fig. 4.4-2 Help Window

#### 4.4.2. Related link

When [Related link] menu is selected, The related link is displayed on a browser. Related link window is shown in Fig. 4.4-3.

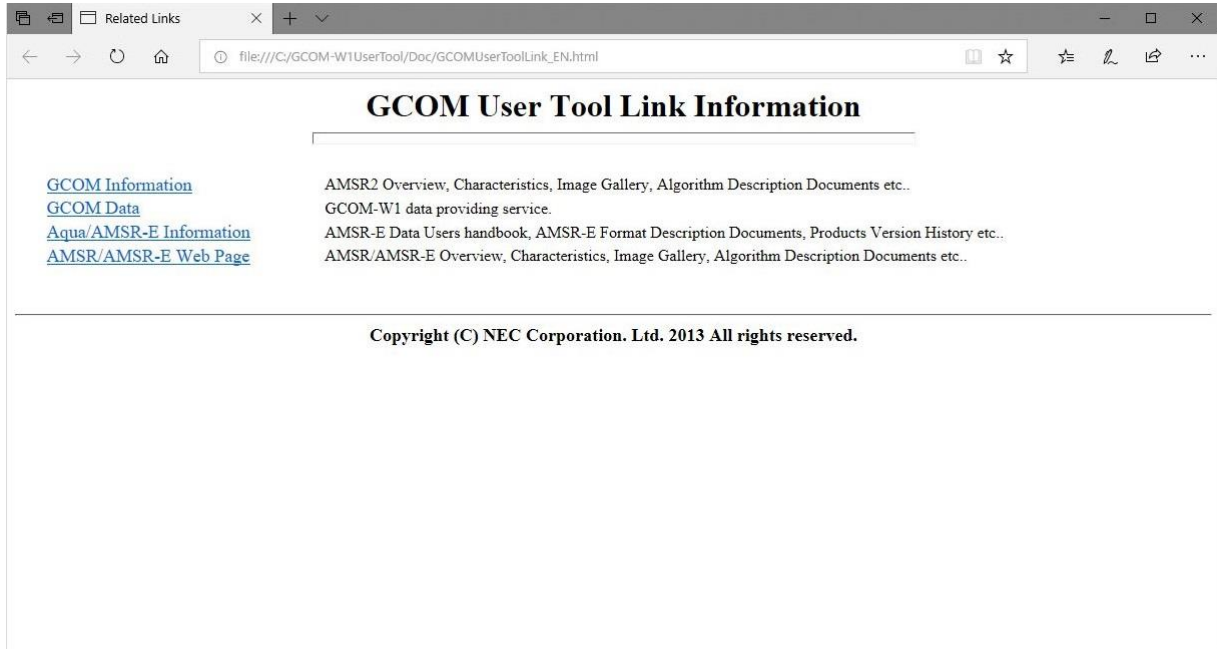

Fig. 4.4-3 Link Window

#### 4.4.3. Version Information

[Version information Dialog] is displayed and version information on this user tool is displayed.

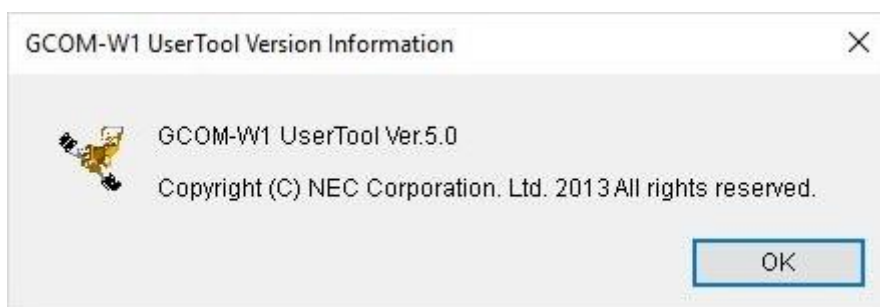

Fig. 4.4-4 Version Information

## Appendix A File Format

It explains the following three kinds of file formats output with GCOM User Tool.

- ① Binary File Format
- ② CSV File Format
- ③ KML File Format
- ④ Color Bar Table File
- ⑤ Look Up Table File
- ⑥ Batch File

### Appendix A.1 Binary File Format

GCOM User Tool outputs is shown in Fig. A.1-1.

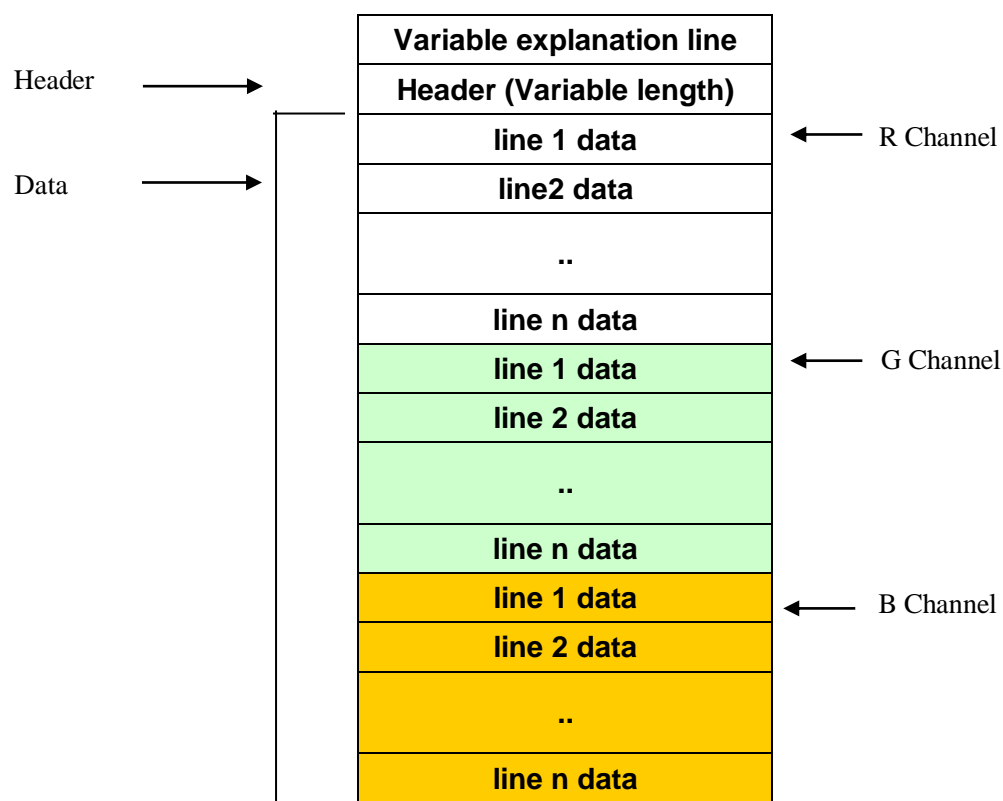

Fig. A.1-1 Binary File Format

A binary file consists of a header record and data records.

Header: Annotation information on the observational data (latitude and longitude information in the sensor name, the number of pixels, the number of lines and four corners etc.) is stored.

Data : The observation data for several channel is stored in BSQ format.

Hereafter, it explains the header and the data division.

#### 1) Header Format

The format of a header is shown in Table A.1-1.

Table A.1-1 Header Format

No.	Item	Description	Note
1	Satellite/ Sensor	Satellite name and sensor name. * AMSR-E: Aqua/AMSR-E * AMSR: ADEOS-II/AMSR * AMSR2: GCOM-W1	
2	Pixel	The number of pixels (observation mark).	
3	Line	The number of lines is stored.	
4	Upper Left latitude(*1)	Upper left latitude	
5	Upper Left longitude(*2)	Upper left longitude	
6	Upper right latitude(*1)	Upper right latitude	
7	Upper right longitude(*2)	Upper right longitude	
8	Lower Left latitude(*1)	Lower left latitude	
9	Lower Left longitude(*2)	Lower left longitude	
10	Lower right latitude(*1)	Lower right latitude	
11	Lower right longitude(*2)	Lower right longitude	
12	Unit	Unit of observation data	When there is not a unit, not set a value.
13	Scale	Scale factor of observation data	When there is not scale factor, set 1.
14	Intercept	Intercept of observation data	When there is not offset, set 0.
15	Copyright	copyright holder	
16	File name	File name of source data	
17	Blank(*3)	The blank (20[hex]) is set.	
18	LF	LF	

\*1 The unit is degree. The data range is assumed to be 90deg from -90deg

\*2 The unit is degree. The data range is assumed to be 180deg from -180deg.

\*3 If the recorded data size of header is less than 512 bytes, it would be fill by blank (20[hex]) until the end of header.

## 2) Data

The data of a channel assigned to RGB (or Single channel) is stored as BSQ format. Size of 1 pixel is 2 bytes. A little endian (default) or a big endian exists in a byte order, but it stores to the byte order specified by a user. You can specified the byte order (a Little endian (default) or Big endian)



## Appendix A.2 CSV File Format

This file is created when saved by [Save Binay Format] of [File] menu. The format of the CSV file which GCOM User Tool outputs is shown in Fig. A.2-1.

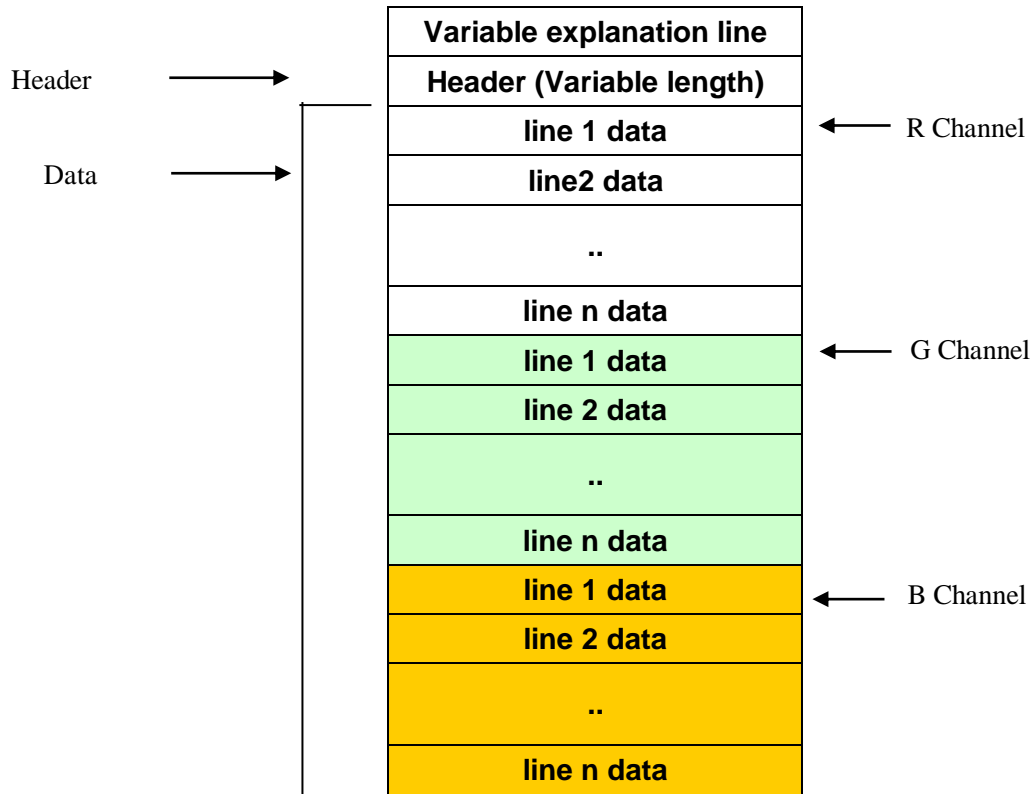

Fig. A.2-1 CSV File Format

A csv file consists of a header record and data records.

**Header**: Annotation information on the observational data (latitude and longitude information in the sensor name, the number of pixels, the number of lines, and four corners etc.) is stored.

**Data**: The observation data for several channel is stored.

Hereafter, it explains the header and the data division.

1) Header Format

The format of a header is shown in Table A.2-1.

Table A.2-1 Header Format

No.	Item	Description	Note
1	Satellite/ Sensor	Satellite name and sensor name. * AMSR-E: Aqua/AMSR-E * AMSR: ADEOS-II/AMSR * AMSR2:GCOM-W1/AMSR2	
2	Pixel	The number of pixels (observation mark).	
3	Line	The number of lines is stored.	
4	Upper Left latitude(*1)	Upper left latitude	
5	Upper Left longitude(*2)	Upper left longitude	
6	Upper right latitude(*1)	Upper right latitude	
7	Upper right longitude(*2)	Upper right longitude	
8	Lower Left latitude(*1)	Lower left latitude	
9	Lower Left longitude(*2)	Lower left longitude	
10	Lower right latitude(*1)	Lower right latitude	
11	Lower right longitude(*2)	Lower right longitude	
12	Unit	Unit of observation data	When there is not a unit, not set a value.
13	Scale	Scale factor of observation data	When there is not scale factor,set 1.
14	Intercept	Intercept of observation data	When there is not offset, set 0.
15	Copyright	copyright holder	
16	File name	File name of source data	
17	Blank(*3)	The blank (20[hex]) is set.	
18	LF	LF	

\*1 The unit is degree. The data range is assumed to be 90deg from -90deg

\*2 The unit is degree. The data range is assumed to be 180deg from -180deg.

\*3 If the recorded data size of header is less than 512 bytes, it would be fill by blank (20[hex]) until the end of header.

## 2) Data Format

The storing format of the data of a channel assigned to RGB (or solid color) is shown below.

(1) The format with latitude and longitude information.

```
#Red Channel
Lon1,lat1,data1,Lon2,lat2,data2, ..... ,LonN,latN,dataN<LF>
:
:
Lon1,lat1,data1,Lon2,lat2,data2, ..... ,LonN,latN,dataN<LF>
#Green Channel
Lon1,lat1,data1,Lon2,lat2,data2, ..... ,LonN,latN,dataN<LF>
:
:
Lon1,lat1,data1,Lon2,lat2,data2, ..... ,LonN,latN,dataN<LF>
#Blue Channel
Lon1,lat1,data1,Lon2,lat2,data2, ..... ,LonN,latN,dataN<LF>
:
:
Lon1,lat1,data1,Lon2,lat2,data2, ..... ,LonN,latN,dataN<LF>
```

(2) The format without latitude and longitude information

```
#Red Channel
data1, data2, ..... ,dataN<LF>
:
:
data1, data2, ..... ,dataN<LF>
#Green Channel
data1, data2, ..... ,dataN<LF>
:
:
data1, data2, ..... ,dataN<LF>
#Blue Channel
data1, data2, ..... ,dataN<LF>
```

## Appendix A.3 KML File Format

KML (Keyhole Markup Language) file is the file which stored the KML tag for displaying the picture file of AMSR/AMSR-E/AMSR2 (Combined) on Google Earth Client(R). This file is created when saved by [**Save KML Format**] of [**File**] menu. The format of the KML file which GCOM User Tool outputs is shown in Fig. A.3-1.

```
<?xml version="1.0" encoding="UTF-8"?>
<kml xmlns="http://earth.google.com/kml/2.0"> (1)KML Header Tag
<Document>
<name> Aqua/AMSR-E </name> (2)Name Tag
<description> (3)Description Tag
    <![CDATA[GranuleID: P1AME090228179MD_P01A0000000.00 : Copyright @ Japan Aerospace
    Exploration
    Agency/Earth Observation Research Center]]>
</description>
<GroundOverlay> (4)Ground Overlay Tag
    <name> Aqua/AMSR-E </name>
    <visibility>1</visibility> (5)Visibility Tag
    <Icon> (6)Icon Tag
    <href>./P1AME090228179MD_P01A0000000.png </href>
    </Icon>
    <LatLonBox> (7)LatLonBox Tag
    <north>90</north>
    <south>-90</south>
    <east>0</east>
    <west>-360</west>
    </LatLonBox>
    <LookAt> (8)LookAt Tag
    <heading>0</heading>
    <latitude>0</latitude>
    <longitude>140</longitude>
    <tilt>0</tilt>
    <range>1800000</range>
    </LookAt>
    <TimeSpan> (11)TimeSpan Tag
    <begin>2003-01-01T00:00:00Z</begin> <end>2003-02-01T00:00:00Z</end>
    </TimeSpan>
```

```

</GroundOverlay>
<ScreenOverlay> (9)ScreenOverlay Tag
    <name>Color Scale Bar</name>
    <Icon>
        <href>./ P1AME090228179MD_P01A0000000_bar.png </href>
    </Icon>
    <overlayXY x="0.5" y="0" xunits="fraction" yunits="fraction"/>
    <screenXY x="0.5" y="10" xunits="fraction" yunits="pixels"/>
    <size x="0" y="0" xunits="fraction" yunits="fraction"/>
    <TimeSpan> (11)TimeSpan Tag
        <begin>2003-01-01T00:00:00Z</begin> <end>2003-02-01T00:00:00Z</end>
    </TimeSpan>
</ScreenOverlay>
<LookAt> (10)LookAt Tag
    <heading>0</heading>
    <latitude>0</latitude>
    <longitude>140</longitude>
    <tilt>0</tilt>
    <range>1800000</range>
</LookAt>
</Document>
</kml>

```

Fig. A.3-1 KML File Format

1) KML Tag

KML tag is shown in Table A.3-1.

Table A.3-1 KML Tag

No.	Tag	Description	Note
1	KML Header Tag	KML2.0 is specified	
2	Name Tag	The label displayed on the window of Google Eart(R) is defined. * AMSR: ADEOS-II/AMSR * AMSR-E: Aqua/AMSR-E * AMSR2 : GCOM-W1/AMSR2	
3	Description Tag	The following information displayed on the window of Google Earth@ is defined. * Granule ID * Copyright	
4	Ground Overlay Tag	Attribute of overlay image is defined.	
5	Visibility Tag	A default setup is set to ON (= 1).	
6	Icon Tag	An image file name is defined.	The display image is assumed to be an image projected by EQR.
7	LatLonBox Tag	The latitude and longitude of the four corners of an image.	
8	LookAt Tag	The following values are defined as a default viewpoint. * latitude=0 (deg) * longitude=140 (deg) * range=18000000 (m) * tilt=0 (deg) * heading=0 (deg)	
9	ScreenOverlay Tag	An image of color scale is defined.	
10	LookAt Tag	(Initial viewpoint) * latitude=0 (deg) * longitude=140 (deg) * range=18000000 (m) * tilt=0 (deg) * heading=0 (deg)	
11	TimeSpan Tag	The period that overlay image displays is defined.	

## Appendix A.4 KML File Format (The Timeline Function)

Timeline supported KML file is the file which stored the KML tag for displaying the picture file of AMSR/AMSR-E/AMSR2 (Combined) on Google Earth™. The Timeline function can display the images which change depending on time. This file is created when saved by **[KML Format]** of the dialog **[Make AMSR/AMSR-E product Animation]**. The format of the time line supported KML file which GCOM User Tool outputs is shown in Fig. A.4-1.

```
<?xml version="1.0" encoding="UTF-8"?>
<kml xmlns="http://earth.google.com/kml/2.0"> (1)KML Header Tag
<Document>
  <name> Aqua/AMSR-E </name> (2)Name Tag
  <description> (3)Description Tag
  <![CDATA[GranuleID: P1AME090228179MD_P01A0000000.00 : Copyright @ Japan
  Aerospace Exploration Agency/Earth
  Observation Research and application Center]]>
  </description>
  <GroundOverlay> (4)Ground Overlay Tag
  <name> Aqua/AMSR-E </name>
  <visibility>1</visibility> (5)Visibility Tag
  <Icon> (6)Icon Tag
  <href>./ P1AME090228179MD_P01A0000000.png </href>
  </Icon>
  <LatLonBox> (7)LatLonBox Tag
  <north>90</north>
  <south>-90</south>
  <east>0</east>
  <west>-360</west>
  </LatLonBox>
  <LookAt> (8)LookAt Tag
  <heading>0</heading>
  <latitude>0</latitude>
  <longitude>140</longitude>
  <tilt>0</tilt>
  <range>18000000</range>
  </LookAt>
  <TimeSpan> (11)TimeSpan Tag
```



```

<begin>2003-01-01T00:00:00Z</begin> <end>2003-02-01T00:00:00Z</end>
</TimeSpan>
</GroundOverlay>
<GroundOverlay> (12) Plural Ground Overlay Tags
...(repeat)...
<TimeSpan>
<begin>2003-02-01T00:00:00Z</begin><end>2003-03-01T00:00:00Z</end>
</TimeSpan>
</GroundOverlay>
...(repeat)...
<ScreenOverlay> (9)ScreenOverlay Tag
<name>Color Scale Bar</name>
<Icon>
<href>./ P1AME090228179MD_P01A0000000_bar.png </href>
</Icon>
<overlayXY x="0.5" y="0" xunits="fraction" yunits="fraction"/>
<screenXY x="0.5" y="10" xunits="fraction" yunits="pixels"/>
<size x="0" y="0" xunits="fraction" yunits="fraction"/>
<TimeSpan> (11)TimeSpan Tag
<begin>2003-01-01T00:00:00Z</begin> <end>2003-02-01T00:00:00Z</end>
</TimeSpan>
</ScreenOverlay>
<LookAt> (10)LookAt Tag
<heading>0</heading>
<latitude>0</latitude>
<longitude>140</longitude>
<tilt>0</tilt>
<range>18000000</range>
</LookAt>
</Document>
</kml>

```

Fig. A.4-1 KML File Format (The Timeline Function)

1) KML Tag

KML tag is shown in Table A.4-1.

Table A.4-1 KML Tag

No.	Tag	Description	Note
1	TimeSpan Tag	The period that overlay image displays is defined.	
2	Plural Ground Overlay Tags	Two or more displayed overlay images are defined. The structure is the same as the overlay image definition having a TimeSpan Tag.	

## **Appendix A.5 HDF format**

This appendix shows the HDF format that is output by “Save as HDF”.  
AMSR2 product file format is described as HDF5.

- Contents

- (1) Metadata

- The Metadata list is shown as Table A.5-1.

- (2) Data set

- All datasets included in original AMSR2 product file are output.

Table A.5-1 The Metadata list of product format(1/4)

No.	Metadata	Explanation	change ("—" means no change)
1	ProductName	Abbreviated name	—
2	GeophysicalName	Geophysical quantity name	—
3	ProductVersion	Product version	—
4	AlgorithmVersion	Algorithm version	—
5	ParameterVersion	Parameter version	—
6	ProductSize_MByte	Product size(MByte)	○: Change to data range size after cutout calculation.
7	GranuleID	Granule ID	—
8	Operation	Product kind	—
9	ProductionDateTime	Product creation time and date (UTC)	○: Change to the time when the file is created.
10	ObservationStartDateTime	Start time and date of observation data(UTC)	○: Change to start time in product file after cutout calculation.
11	ObservationEndDateTime	End time and date of observation data(UTC)	○: Change to end time in product file after cutout calculation.
12	GringPointLatitude	Latitude of data effective range	○: Change to data range size after cutout calculation.
13	GringPointLongitude	Longitude of data effective range	○: Change to data range size after cutout calculation.
14	PGENAME	Data processing software name	—
15	InputFileName	Input file name (Level0 data file name)	—
16	ProcessingCenter	Data processing center	—
17	ContactOrganizationName	Contact organization name	—
18	ContactOrganizationTelephone	Contact telephone number	—
19	StartOrbitNumber	Start orbit number	—
20	StopOrbitNumber	End orbit number	—
21	EquatorCrossingLongitude	Longitude at the time of equatorial passage	—
22	EquatorCrossingDateTime	Time and date of equatorial passage(UTC)	—
23	OrbitDirection	Orbit direction	—
24	PassNumber	Pass number of observation start point	—
25	OrbitDataFileName	Support orbit file name	—
26	EphemerisMissingDataRate	Missing rate of orbit data	—
27	AttitudeMissingDataRate	Missing rate of attitude data	—
28	OrbitDataType	orbit data type	—

Table A.5-1 The Metadata list of product format(2/4)

No.	Metadata	Explanation	change ("—" means no change)
29	PlatformShortName	Platform name	—
30	SensorShortName	Sensor names	—
31	NumberOfScans	Number of scan	○: Change to data range size after cutout calculation.
32	NumberOfMissingScans	Number of missing scans	○:*2
33	AntennaRotationVelocity	Velocity of antenna rotation (30~40rpm)	—
34	ECSDataModel	Meta data model name	—
35	NumberOfPackets	Number of level 0 packets	—
36	NumberOfInputFiles	Number of input level 0 files	—
37	NumberMissingPackets	Number of missing packets	○:*2
38	NumberOfGoodPackets	Number of packets	○:*2
39	OverlapScans	Number of overlap scans(One side)	○: Change to 0 after cutout calculation.
40	QALocationOfPacketDiscontinuity	Continuity of Packet Sequence Counter	—
41	EphemerisQA	Ephemeris limit check	—
42	AutomaticQAFlag	Limit check by software	—
43	ScienceQualityFlag	Quality flag of calculating geophysical quantity	—
44	ScienceQualityFlagExplanation	Explanation of “ScienceQualityFlag”	—
45	AutomaticQAFlagExplanation	Explanation of limit check by software	—
46	QAPercentMissingData	Number of missing data	—
47	QAPercentOutofBoundsData	Percentage of out of bound data(%)	—
48	QAPercentParityErrorData	Percentage of parity error data	—
49	ProcessingQADescription	Description of the processing error	—
50	ProcessingQAAttribute	The attribute name which is abnormal by QA metadata	—
51	GlobalMeteorologicalDataType	Used meteorological data	—
52	AncillaryDataInformation	Information of ancillary data (Used data in Level 2 process)	—
53	SatelliteOrbit	The kind of Satellite's orbit	—
54	SatelliteAltitude	The altitude of Satellite	—
55	OrbitSemiMajorAxis	The orbit semi-major axis	—
56	OrbitEccentricity	The orbit eccentricity	—
57	OrbitArgumentPerigee	The orbit argument perigee	—
58	OrbitInclination	The orbit inclination	—

Table A.5-1 The Metadata list of product format(3/4)

No.	Metadata	Explanation	change ("-" means no change)
59	OrbitPeriod	The orbit period	—
60	RevisitTime	Orbit recurrent days	—
61	AMSRChannel	The kind of AMSR channels	—
62	AMSRBandWidth	Band width of AMSR	—
63	AMSRBeamWidth	Beam width of AMSR	—
64	OffNadir	Off-nadir angle	—
65	SpatialResolution	Spatial resolution (Az x El)	—
66	ScanningPeriod	Scanning period	—
67	SwathWidth	Swath width	—
68	DynamicRange	Dynamic range	—
69	DataFormatType	Data format type	—
70	HDFFormatVersion	HDF format version	—
71	EllipsoidName	Earth ellipse model	—
72	SemiMajorAxisofEarth	earth equatorial radius	—
73	FlatteningRatioofEarth	Flattening ratio of earth	—
74	SensorAlignment	Sensor alignment	—
75	Thermistor1CountRange	Thermistor#1 count range	—
76	Thermistor1ConversionTableD	Thermistor#1 conversion table D	—
77	Thermistor1ConversionTableE	Thermistor#1 conversion table E	—
78	Thermistor1ConversionTableF	Thermistor#1 conversion table F	—
79	Thermistor2CountRange	Thermistor#2 count range	—
80	Thermistor2ConversionTableW4	Thermistor#2 conversion table W4	—
81	Thermistor2ConversionTableW3	Thermistor#2 conversion table W3	—
82	Thermistor2ConversionTableW2	Thermistor#2 conversion table W2	—
83	Thermistor2ConversionTableW1	Thermistor#2 conversion table W1	—
84	Thermistor2ConversionTableW0	Thermistor#2 conversion table W0	—
85	Thermistor3CountRange	Thermistor#3 count range	—
86	Thermistor3ConversionTableW4	Thermistor#3 conversion table W4	—
87	Thermistor3ConversionTableW3	Thermistor#3 conversion table W3	—
88	Thermistor3ConversionTableW2	Thermistor#3 conversion table W2	—
89	Thermistor3ConversionTableW1	Thermistor#3 conversion table W1	—
90	Thermistor3ConversionTableW0	Thermistor#3 conversion table W0	—
91	Platinum1CountRange	Platinum#1 count range	—
92	Platinum1ConversionTableW4	Platinum#1 conversion table W4	—
93	Platinum1ConversionTableW3	Platinum#1 conversion table W3	—

Table A.5-1 The Metadata list of product format(4/4)

No.	Metadata	Explanation	change ("-" means no change)
94	Platinum1ConversionTableW2	Platinum#1 conversion table W2	—
95	Platinum1ConversionTableW1	Platinum#1 conversion table W1	—
96	Platinum1ConversionTableW0	Platinum#1 conversion table W0	—
97	Platinum2CountRange	Platinum#2 count range	—
98	Platinum2ConversionTableW4	Platinum#2 conversion table W4	—
99	Platinum2ConversionTableW3	Platinum#2 conversion table W3	—
100	Platinum2ConversionTableW2	Platinum#2 conversion table W2	—
101	Platinum2ConversionTableW1	Platinum#2 conversion table W1	—
102	Platinum2ConversionTableW0	Platinum#2 conversion table W0	—
103	Platinum3ConversionTableW4	Platinum#3 conversion table W4	—
104	Platinum3ConversionTableW3	Platinum#3 conversion table W3	—
105	Platinum3ConversionTableW2	Platinum#3 conversion table W2	—
106	Platinum3ConversionTableW1	Platinum#3 conversion table W1	—
107	Platinum3ConversionTableW0	Platinum#3 conversion table W0	—
108	CoefficientAvv	Brightness temperature coefficient Avv	—
109	CoefficientAhv	Brightness temperature coefficient Ahv	—
110	CoefficientAov	Brightness temperature coefficient Aov	—
111	CoefficientAhh	Brightness temperature coefficient Ahh	—
112	CoefficientAvh	Brightness temperature coefficient Avh	—
113	CoefficientAoh	Brightness temperature coefficient Aoh	—
114	CSMTemperature	Brightness temperature of deep space	—
115	CoRegistrationParameterA1	Co-registration parameter A1	—
116	CoRegistrationParameterA2	Co-registration parameter A2	—
117	CalibrationCurveCoefficient1	The radiometric correction coefficient for the 0th order	—
118	CalibrationCurveCoefficient2	The radiometric correction coefficient for the 1st order	—
119	CalibrationCurveCoefficient3	The radiometric correction coefficient for the 2nd order	—
120	CalibrationCurveCoefficient4	The radiometric correction coefficient for the 3rd order	—
121	CalibrationCurveCoefficient5	The radiometric correction coefficient for the 4th order	—
122	CalibrationMethod	Calibration method name	—

\*1 No.53~122 aren't output in the AMSR2 Level2 product, because the AMSR2 Level 2 product doesn't include them .

\*2 It is calculated by "Scan Data Quality" item in Level 1 product.

"NumberOfMissingScans", "NumberMissingPackets", "NumberOfGoodPackets" are stored "-" in Level 2 product, because they haven't enough information with calculation.



## Appendix A.6 Color Bar Table File Format

For an image window of Single Channel image, the applied Color Bar Table file for the image is shown on [Color Bar Table] pull down located below [Tool Bar]. Some typical Color Bar Table files are stored in the color table / look-up table folder. You can edit these files and save your own Color Bar Table. You can also edit it with a text editor such as WordPad or Notepad.

Table A.6-1 Color Bar Table File Format

Parameters	Format	Descriptions
Title	//character string	The default is " AMSR ORBIT Viewer COLOR TABLE DEFINE "
Number of Points	N = n	n is an integer selected from 2, 3, 5 or 9.
Logarithm Interpolation	LOG_MODE = <i>value</i>	<i>value</i> is set "ON" or "OFF".
Inserting Color Bar mode	REVERS_MODE= <i>value</i>	<i>value</i> is set "ON" or "OFF".
Relation between Data Value and RGB Color Value at point 1	VAL = real value. [TAB] COLOR = n1, n2, n3 *[TAB] means Tab key.	real value is -9999,0~9999,0 n1, n2 and n3 are Color Value of red, green and blue respectively and its value is between 0 and 255.
Relation between Data Value and RGB Color Value at pointN	same as above	same as above

```
// AMSR HDF TOOL COLOR TABLE DEFINE

N = 9
LOG_MODE = OFF
REVERSE_MODE = OFF
TITLE_NAME = [AMSR-E Brightness Temperature [K] ]
VAL = 154.800003 COLOR = 0,0,255
VAL = 176.225006 COLOR = 0,128,255
VAL = 197.649994 COLOR = 0,255,255
VAL = 219.074997 COLOR = 0,255,128
VAL = 240.500000 COLOR = 0,255,0
VAL = 261.924988 COLOR = 128,255,0
VAL = 283.350006 COLOR = 255,255,0
VAL = 304.774994 COLOR = 255,128,0
VAL = 326.200012 COLOR = 255,0,0
```

Fig. A.6-1 A Sample of Color Bar Table

## Appendix A.7 Look Up Table File Format

For an image window of RGB Composite image, the applied Look Up Table file for the image is shown on [Look Up Table] pull down located below [Tool Bar]. A typical Look Up Table file ("standard\_stretch.lut") is stored in the "param" folder. You can edit it and save your own Look Up Table. You can also edit it with a text editor such as WordPad or Notepad.

Table A.7-1 Look Up Table File Format

Parameters	Format	Descriptions
Title	//character string	The value is " AMSR ORBIT Viewer Brightness Stretch DEFINE "
Comment	// character string	The default is blank.
Comment	// character string	The value is " physical amount(Minimum), physical amount(Maximum), display value (Minimum), display value Maximum) "
Red Color Value	$R\Delta = \Delta R_{n1}, R_{n2}, n1, n2$ $\Delta$ is space $R_n$ is real number	$R_{n1}$ = Arbitrariness $R_{n2}$ = Arbitrariness $n1 = 0 \sim 255$ $n2 = 0 \sim 255$
Green Color Value	$G\Delta = \Delta R_{n1}, R_{n2}, n1, n2$ $\Delta$ is space $R_n$ is real number	$R_{n1}$ = Arbitrariness $R_{n2}$ = Arbitrariness $n1 = 0 \sim 255$ $n2 = 0 \sim 255$
Blue Color Value	$B\Delta = \Delta R_{n1}, R_{n2}, n1, n2$ $\Delta$ is space $R_n$ is real number	$R_{n1}$ = Arbitrariness $R_{n2}$ = Arbitrariness $n1 = 0 \sim 255$ $n2 = 0 \sim 255$

```
// AMSR HDF TOOL STRETCH TABLE DEFINE
```

```
N = 9
```

```
LOG_MODE = OFF
```

```
VAL_R = 154.800003 COLOR_R = 0
```

```
VAL_R = 176.225006 COLOR_R = 31
```

```
VAL_R = 197.649994 COLOR_R = 63
```

```
VAL_R = 219.074997 COLOR_R = 95
```

```
VAL_R = 240.500000 COLOR_R = 127
```

```
VAL_R = 261.924988 COLOR_R = 159
```

```
VAL_R = 283.350006 COLOR_R = 191
```

```
VAL_R = 304.774994 COLOR_R = 223
```

```
VAL_R = 326.200012 COLOR_R = 255
```

Fig A.7-1 the sample of Look up table

## **Appendix A.8 Batch File**

The batch file is a file that manages information on the batch processing of the GCOM User Tool.

The batch file can be edited with the text editor such as WordPad or the note pads.

Use half-width spaces to partition the format, because it cannot recognize full-width spaces as the partition.

Batch file format is shown in the Table A.8-1.

Table A.8-1 Batch File Format(1/4)

Parameters	Format	Descriptions
Data display	VIEWHDF [T] [/L] [/S   /RGB] [/M] [/C] [/I] [/V] */M、/C、/V is possible to omit	<p>/T Sensor type: AMSR2、AMSR、AMSR-E [Ex:/T AMSR2]</p> <p>/L Product: L1A、L1B、L1R、L2、L3、L1BMap、 L2Map [Ex:/L L1A]</p> <p>/S*5 *7 (Not possible to specify simultaneously with RGB) Display channel (L1A,L1B): 6V、6H、7V、7H、 10V、10H、18V、18H、23V、23H、36V、36H、 89AV、89AH、89BV、89BH、50V、52V [Ex:/S 18V]</p> <p>Channel (L1R): The value in which six -10-23-36-89- is added is specified ahead of the value in which 89V and 89H are added to the channel of L1A and L1B. [Ex:/S 6-6V]</p> <p>Channel (L2): The channel with the number of hierarchy in the product file.(Low resolution: 1 or 2. High resolution: 89A-1, 89A-2, 89B-1 or 89B-2) [Ex:/S 89A-1]</p> <p>/RGB*5(Not possible to specify simultaneously with /S) The channel is specified in order of RGB. [Ex:/RGB 6V 10V 18V]</p> <p>/M Map projection: EQR、ORTHO、PN、PS、PNS*8、 MER When omitting it, it displays it by the default map projection of each product type . [Ex:/M EQR]</p> <p>/C The color bar or the look-up table file name is specified. When omitting it, it becomes Automatic. [Ex:/C AM2L1A.clt]</p> <p>/I*4 Product file list name (*1) is specified. [Ex:/I amsr2Filelist.txt]</p> <p>/V Display/non-display : ON、OFF Display/non-display under the batch processing is specified. When omitting it, it becomes turning on (display). [Ex:/V OFF]</p>

Table A.8-1 Batch File Format(2/4)

Parameters	Format	Descriptions
Image Output	OUTIMG [/R] [/F] [/O]	<p>/R*2 Display range: Latitude on the left, Longitude on the left, Latitude under the right and longitude under the right is specified. [Ex: /R 36 138.9 34.9 140.28]</p> <p>/F Format: BMP, JPEG, TIFF, PNG [Ex: /F JPEG]</p> <p>/O*4 *6 The output file name is specified. [Ex: /O output.jpg]</p>
Animation	OUTMOV [/T] [/L] [/F] [/S] [/C] [/I] [/O] */C is possible to omit.	<p>/T Sensor type: AMSR2, AMSR, AMSR-E [Ex: /T AMSR2]</p> <p>/L Product: L1A, L1B, L1R, L2, L3, L1BMap, L2Map [Ex: /L L1A]</p> <p>/F Format: AVI, KML, KMZ [Ex: /F AVI]</p> <p>/S*5 *7 Channel (L1A,L1B): 6V, 6H, 7V, 7H, 10V, 10H, 18V, 18H, 23V, 23H, 36V, 36H, 89AV, 89AH, 89BV, 89BH, 50V, 52V [Ex: /S 18V]</p> <p>Channel (L1R): The value in which six -10-23-36-89- is added is specified ahead of the value in which 89V and 89H are added to the channel of L1A and L1B. [Ex: 6-6V]</p> <p>Channel (L2): The channel with the number of hierarchy in the product file.(Low resolution : 1 or 2. High resolution : 89A-1, 89A-2, 89B-1 or 89B-2) [Ex: /S 89A-1]</p> <p>/C The Look Up Table file name is specified. When omitting it, it becomes Automatic. [Ex: /C AM2L1A.clt]</p> <p>/I*4 Product file list name is specified. [Ex: /I amsr2Filelist.txt]</p> <p>/O*4 *6 The output file name is specified. [Ex: /O MovieFile.avi]</p>

Table A.8-1 Batch File Format(3/4)

Parameters	Format	Descriptions
CSV output	OUTCSV [/R] [/G] [/O] */G is possible to omit.	<p>/R*2 Display range: Latitude on the left, Longitude on the left, Latitude under the right and longitude under the right is specified. [Ex: /R 36 138.9 34.9 140.28]</p> <p>/G Latitude and longitude existence: When omitting it, it becomes it if there is no latitude and longitude. /O*4 *6 The output file name is specified. [Ex: /O output.csv]</p>
Binary	OUTBIN [/R] [/O]	<p>/R*2 Display range: Latitude on the left, Longitude on the left, Latitude under the right and longitude under the right is specified. [Ex: /R 36 138.9 34.9 140.28]</p> <p>/O*4 *6 The output file name is specified. [Ex: /O BinaryFile.bin]</p>
Zoom in/Zoom out, Pan	CHANGEMAP [/Z] [/C] [/W] */W is possible to omit.	<p>/Z Expansion rate: The integral value from 1 to 256 is specified. [Ex: /Z 128]</p> <p>/C*2 Center coordinates of image: Center latitude, Center longitude [Ex: /C 36 140.28]</p> <p>/W*3 Window size: It specifies it in order of X coordinates and Y coordinates. When omitting it, it doesn't change. [Ex: /W 800 500]</p>
HDF Output	OUTHDF [/T] [/L] [/S]   /RGB] [/M] [/C] [/I] [/V] [/R] [/O] */M, /C, /V, /O are possible to omit.	<p>/T Sensor type: AMSR2 [Ex: /T AMSR2]</p> <p>/L Product: L1A, L1B, L1R, L2, L3, [Ex: /L L1B]</p> <p>/RGB*5(Not possible to specify simultaneously with /S) The channel is specified in order of RGB. [Ex: /RGB 6V 10V 18V]</p> <p>/S*5 *7</p>



Table A.8-1 Batch File Format(4/4)

Parameters	Format	Descriptions
		<p>(Not possible to specify simultaneously with RGB)            Display channel (L1A,L1B): 6V、6H、7V、7H、10V、10H、18V、18H、23V、23H、36V、36H、89AV、89AH、89BV、89BH、50V、52V            [Ex: /S 18V]</p> <p>Channel (L1R): The value in which six -10-23-36-89- is added is specified ahead of the value in which 89V and 89H are added to the channel of L1A and L1B.            [Ex: /S 6-6V]</p> <p>Channel (L2): The channel with the number of hierarchy in the product file.(Low resolution : 1 or 2. High resolution : 89A-1, 89A-2, 89B-1 or 89B-2)            [Ex: /S 89A-1]</p> <p>/RGB*5(Not possible to specify simultaneously with /S)            The channel is specified in order of RGB.            [Ex: /RGB 6V 10V 18V]</p> <p>/M            Map projection : EQR、ORTHO、PN、PS、PNS*8、MER            When omitting it, it displays it by the default map projection of each product type .            [Ex: /M EQR]</p> <p>/C            The Look Up Table file name is specified.            When omitting it, it becomes Automatic.            [Ex: /C AM2L1A.clt]</p> <p>/I*4            Product file list name is specified.            [Ex: /I amsr2Filelist.txt]</p> <p>/O*4 *6            The output file name is specified.            [Ex: /O MovieFile.avi]</p> <p>/V            Display/non-display : ON、OFF            Display/non-display under the batch processing is specified. When omitting it, it becomes turning on (display).            [Ex: /V OFF]</p> <p>/R*2            Display range: Latitude on the left, Longitude on the left, Latitude under the right and longitude under the right is specified.            [Ex: /R 36 138.9 34.9 140.28]</p>

- \*1 Text file that stored product file passing. The file name of each product is described by one file a line in the full path, and CR+LF is used for the line-feed character.
- \*2 Latitude is specified within the range of  $-90^{\circ}$ ~ $90^{\circ}$ . Longitude is specified within the range of  $-180^{\circ}$ ~ $180^{\circ}$ .
- \*3 It specifies it within the range up to  $1600 \times 1200$  and size or less minimum size  $100 \times 100$ .
- \*4 The file name specification in the full path is enabled.
- \*5 When the product type is level 2 and level 3, it is assumed that the channel is specified unnecessary.
- \*6 When the extension is not described, the extension is added automatically. When the extension is wrong, a correct extension is added to the described file name.
- \*7 Only when AMSR/AMSR-E is selected by the sensor type, 50V and 52V are effective. Moreover, only when AMSR2 is selected by the sensor type, 7V and 7H are effective.
- \*8 The northern hemisphere and the southern hemisphere of the Pola stereographic projection are displayed to the same window.

## **Appendix A.9 Initial Parameter File Format**

Initial Parameter File (GCOM User Tool.ini) is stored in the same folder where the executable binary code of GCOM User Tool. and two sets of dynamic link library (hd421m.dll and hm421m.dll) are stored. It defines the directory information of GCOM User Tool. Folder which is created during the installation by its installer.

Table A.9-1 Initial Parameter File Format(1/3)

Parameter	Format	Descriptions
<b>Descriptor</b>	<b>[DIR]</b>	<b>Fixed.</b>
Parameter Folder Name	DEF_FILE=folder_name	The folder name for saving Parameter File. (by the absolute path.)
Input AMSR2 Data Folder Name	INPUT_DIR=folder_name	The folder name at AMSR2 Data input destination (by the absolute path.)
Input AMSR/AMSR Data Folder Name	INPUT_DIR=folder_name	The folder name at AMSR/AMSR Data input destination (by the absolute path.)
Output AMSR2 Data Folder Name	OUTPUT_DIR =folder_name	The folder name at AMSR2 Data output destination (by the absolute path.)
Input AMSR2 animation Folder Name	INPUT_DIR_MOVIE=folder_name	The folder name at AMSR2 animatio input destination (by the absolute path.)
Input AMSR/AMSR-E animation Folder Name	INPUT_DIR_MOVIE_AMSR-E= folder_name	The folder name at AMSR/AMSR-E animatio input destination (by the absolute path.)
Output AMSR2 animation Folder Name	OUTPUT_DIR_MOVIE=folder_name	The folder name at AMSR2 animatio output destination (by the absolute path.)
<b>Descriptor</b>	<b>[GENERIC]</b>	<b>Fixed.</b>
Number of read file	MAX_FILE=N	The maximum number of a reading file.
Endian	ENDIAN=0	Byte order for binary file. 0:BIG ENDIAN 1:LITTLE ENDIAN
Non-Observation data value.(Signed)	INV_DATA_VAL=N (Signed)	Non-Observation data value when binary form is output.
Non-Observation data value.(Unsigned)	INV_DATA_VAL_UN=N (Unsigned)	Non-Observation data value when binary form is output.
Number of the points	N_COL=N	Number of the points output to one record to a CSV file.

Table A.9-1 Initial Parameter File Format(2/3)

Parameter	Format	Descriptions
Decimal place of output data	N_FRAC=N	Decimal place of output data to a CSV file.
Color of the coast line	COLOR_SHORELINE= VALUE	Saving the color of the coast line (The value is hexadecimal numbers[ABGR] )
Color of the helpline	COLOR_HELPLINE=VALUE	Saving the color of the helpline (The value is hexadecimal numbers[ABGR] )
Color of the equator	COLOR_EQUATOR=VALUE	Saving the color of the equator (The value is hexadecimal numbers[ABGR] )
Color of the background.	COLOR_BACK=VALUE	Saving the color of the back (The value is hexadecimal numbers [ABGR] )
Presence of the coast line	DRAW_SHORELINE= TRUE or FALSE	Presence of the coast line TRUE : display FALSE : non-display
Presence of the helpline	DRAW_HELPLINE= TRUE or FALSE	Presence of the helpline TRUE : display FALSE : non-display
Presence of the equator	DRAW_EQUATOR= TRUE or FALSE	Presence of the equator TRUE : display FALSE : non-display
Presence of the background	DRAW_BACK= TRUE or FALSE	Presence of the background TRUE : display FALSE : non-display
Presence of Specification at latitude and longitude line intervals	LATLON_MODE= TRUE or FALSE	Presence of Specification at latitude and longitude line intervals TRUE : display FALSE : non-display
Interval in latitude line	LAT_WIDTH= VALUE	Interval in latitude line The latitude line is displayed at intervals. (Value÷10(°))

Table A.9-1 Initial Parameter File Format(3/3)

Parameter	Format	Descriptions
Interval in longitude line	LON_WIDTH= VALUE	Interval in longitude line The longitude line is displayed at intervals. (Value:10(°))
Setting on image or which below to display coastline	DRAW_SHORELINEORDER = VALUE	Setting on image or which below to display coastline Default is displayed on
<b>Generic Descriptor</b>	[MAP]	<b>Fixed.</b>
Automatic change setting of map file	MAP_MODE= VALUE	Automatic change setting of map file 0:Fixed 1:Automatic
Map file definition	MAP_FILE=file name	When the map file name (Specify it by the absolute path) and the map file automatic operation change is set, it is one expansion rate time or more. Map file name used for less than eight times
Map file definition 2	MAP_FILE2= file name	When the map file automatic operation change is set, it is eight expansion rate times or more. Map file name used for 256 times or less

## Appendix B Licenses

### Appendix B.1 HDF4

This software includes the HDF4 library, uses and distributions have been permitted under following conditions.

Copyright Notice and License Terms for  
Hierarchical Data Format (HDF) Software Library and Utilities

Hierarchical Data Format (HDF) Software Library and Utilities  
Copyright 2006-2010 by The HDF Group.

NCSA Hierarchical Data Format (HDF) Software Library and Utilities  
Copyright 1988-2006 by the Board of Trustees of the University of Illinois.

All rights reserved.

Redistribution and use in source and binary forms, with or without modification, are permitted for any purpose (including commercial purposes) provided that the following conditions are met:

1. Redistributions of source code must retain the above copyright notice, this list of conditions, and the following disclaimer.
2. Redistributions in binary form must reproduce the above copyright notice, this list of conditions, and the following disclaimer in the documentation and/or materials provided with the distribution.
3. In addition, redistributions of modified forms of the source or binary code must carry prominent notices stating that the original code was changed and the date of the change.
4. All publications or advertising materials mentioning features or use of this software are asked, but not required, to acknowledge that it was developed by The HDF Group and by the National Center for Supercomputing Applications at the University of Illinois at Urbana-Champaign and credit the contributors.
5. Neither the name of The HDF Group, the name of the University, nor the

name of any Contributor may be used to endorse or promote products derived from this software without specific prior written permission from The HDF Group, the University, or the Contributor, respectively.

**DISCLAIMER:**

**THIS SOFTWARE IS PROVIDED BY THE HDF GROUP AND THE CONTRIBUTORS "AS IS" WITH NO WARRANTY OF ANY KIND, EITHER EXPRESSED OR IMPLIED. In no event shall The HDF Group or the Contributors be liable for any damages suffered by the users arising out of the use of this software, even if advised of the possibility of such damage.**



## Appendix B.1 HDF5

This software includes the HDF5 library, uses and distributions have been permitted under following conditions.

Copyright Notice and License Terms for  
HDF5 (Hierarchical Data Format 5) Software Library and Utilities

HDF5 (Hierarchical Data Format 5) Software Library and Utilities  
Copyright 2006-2010 by The HDF Group.

NCSA HDF5 (Hierarchical Data Format 5) Software Library and Utilities  
Copyright 1998-2006 by the Board of Trustees of the University of Illinois.

All rights reserved.

Redistribution and use in source and binary forms, with or without modification, are permitted for any purpose (including commercial purposes) provided that the following conditions are met:

1. Redistributions of source code must retain the above copyright notice, this list of conditions, and the following disclaimer.
2. Redistributions in binary form must reproduce the above copyright notice, this list of conditions, and the following disclaimer in the documentation and/or materials provided with the distribution.
3. In addition, redistributions of modified forms of the source or binary code must carry prominent notices stating that the original code was changed and the date of the change.
4. All publications or advertising materials mentioning features or use of this software are asked, but not required, to acknowledge that it was developed by The HDF Group and by the National Center for Supercomputing Applications at the University of Illinois at Urbana-Champaign and credit the contributors.

5. Neither the name of The HDF Group, the name of the University, nor the name of any Contributor may be used to endorse or promote products derived from this software without specific prior written permission from The HDF Group, the University, or the Contributor, respectively.

**DISCLAIMER:**

**THIS SOFTWARE IS PROVIDED BY THE HDF GROUP AND THE CONTRIBUTORS "AS IS" WITH NO WARRANTY OF ANY KIND, EITHER EXPRESSED OR IMPLIED.** In no event shall The HDF Group or the Contributors be liable for any damages suffered by the users arising out of the use of this software, even if advised of the possibility of such damage.

## Appendix B.1 zlib

This software uses a part of source code of zlib. As for the source code of zlib, use has been permitted under the following condition.

a copy at <http://opensource.org/licenses/zlib-license.php>

This software is provided 'as-is', without any express or implied warranty. In no event will the authors be held liable for any damages arising from the use of this software.

Permission is granted to anyone to use this software for any purpose, including commercial applications, and to alter it and redistribute it freely, subject to the following restrictions:

1. The origin of this software must not be misrepresented; you must not claim that you wrote the original software. If you use this software in a product, an acknowledgment in the product documentation would be appreciated but is not required.
2. Altered source versions must be plainly marked as such, and must not be misrepresented as being the original software.
3. This notice may not be removed or altered from any source distribution.